

Asian Import Vehicle Communication Software Manual

February 2011

EAZ0025B02H Rev. B

Trademarks Acknowledgements

Snap-on is a trademark of Snap-on Incorporated.

All other marks are trademarks of their respective holders.

Copyright Information

©2011 Snap-on Incorporated

All rights reserved.

Disclaimer

The information, specifications and illustrations in this manual are based on the latest information available at the time of printing.

Snap-on reserves the right to make changes at any time without notice.

Visit our Web site at:

<http://diagnostics.snapon.com>

For Technical Assistance Call:

1-800-424-7226

Safety Information

For your own safety and the safety of others, and to prevent damage to the equipment and vehicles upon which it is used, it is important that the accompanying *Safety Information* be read and understood by all persons operating, or coming into contact with, the equipment. We suggest you store a copy near the unit in sight of the operator

This product is intended for use by properly trained and skilled professional automotive technicians. The safety messages presented throughout this manual are reminders to the operator to exercise extreme care when using this test instrument.

There are many variations in procedures, techniques, tools, and parts for servicing vehicles, as well as in the skill of the individual doing the work. Because of the vast number of test applications and variations in the products that can be tested with this instrument, we cannot possibly anticipate or provide advice or safety messages to cover every situation. It is the automotive technician's responsibility to be knowledgeable of the system being tested. It is essential to use proper service methods and test procedures. It is important to perform tests in an appropriate and acceptable manner that does not endanger your safety, the safety of others in the work area, the equipment being used, or the vehicle being tested.

It is assumed that the operator has a thorough understanding of vehicle systems before using this product. Understanding of these system principles and operating theories is necessary for competent, safe and accurate use of this instrument.

Before using the equipment, always refer to and follow the safety messages and applicable test procedures provided by the manufacturer of the vehicle or equipment being tested. Use the equipment only as described in this manual.

Read, understand and follow all safety messages and instructions in this manual, the accompanying safety manual, and on the test equipment.

Safety Message Conventions

Safety messages are provided to help prevent personal injury and equipment damage. All safety messages are introduced by a signal word indicating the hazard level.

DANGER

Indicates an imminently hazardous situation which, if not avoided, will result in death or serious injury to the operator or to bystanders.

WARNING

Indicates a potentially hazardous situation which, if not avoided, could result in death or serious injury to the operator or to bystanders.

CAUTION

Indicates a potentially hazardous situation which, if not avoided, may result in moderate or minor injury to the operator or to bystanders.

Safety messages contain three different type styles.

- Normal type states the hazard.
- Bold type states how to avoid the hazard.
- Italic type states the possible consequences of not avoiding the hazard.

An icon, when present, gives a graphical description of the potential hazard.

Example:

 **WARNING**



Risk of unexpected vehicle movement.

- **Block drive wheels before performing a test with engine running.**

A moving vehicle can cause injury.

Important Safety Instructions

For a complete list of safety messages, refer to the accompanying safety manual.

SAVE THESE INSTRUCTIONS

Table of Contents

Safety Information	iii
Safety Message Conventions	iii
Important Safety Instructions	iv
Table of Contents	v
Chapter 1: Using This Manual	1
Conventions	1
Bold Text	1
Terminology	1
Notes and Important Messages	2
Notes	2
Important	2
Chapter 2: Introduction	3
Chapter 3: Operations	4
Selecting the Software	4
Identifying a Vehicle	5
Selecting a System	5
Connecting to the Vehicle	6
Main Menu Selections	8
Code Functions	8
Reading Different Code Types	9
Automatic Code Reading	10
Clearing Codes	10
Printing Codes	10
Manual Code Entry	10
How to Get Codes	11
Reviewing Codes	11
Chapter 4: Acura	12
Testing Engine Systems	12
Code Reading Connectors and Locations	12
ECM Locations 1986 to 1990 with ECM LED	14
SCS mode	16
Code Type	17
Manual Code Reading (Engine Codes)	17
Multiple Codes	18
Testing Transmission Systems	19
Code Reading Connector Locations	19
Manual Code Reading (Transmission Codes)	21
Testing Antilock Brake Systems (ABS)	22
Code Reading Connectors and Locations	22
ABS Codes and Data Testing	23
Manual Code Reading (ABS Codes) and Clearing Codes	25
Testing Supplemental Restraint Systems (SRS)	28
SRS Main Menu	28

Manual Code Reading (SRS).....	29
Code Clearing (SRS Codes).....	31
Chapter 5: Chrysler Imports.....	33
Testing Engine, Transmission, ABS, and SRS.....	33
Code Reading Connectors and Locations	33
ABS Manual Code Reading	36
Clearing Codes	36
Codes and Data (Slow)	37
Actuator Tests	37
EVAP Monitoring Test.....	37
4ITE/F4ACI Quick Learn	38
4ITE/F4AC1 EMCC Reset	38
4ITE/F4AC1 Battery Disconnect	38
4ITE/F4AC1 Pinion Factor	38
4ITE/F4AC1 Clutch Volume Index (CVI) Display	39
Chapter 6: Daihatsu.....	40
Testing Engine, Transmission, and ABS	40
Code Reading Connectors and Locations	40
Manual Code Reading	41
Testing Transmission Systems.....	42
Code Reading Connector Locations (Transmission)	42
Chapter 7: Geo.....	44
Testing Engine, Transmission, and Antilock Brake Systems	44
Code Reading Connectors and Locations	44
Hard Codes and Soft Codes	51
Clearing Codes	51
Field Service Functional Tests	52
Prizm Actuator Tests.....	52
Chapter 8: Honda.....	54
Testing Engine and Transmission Systems	54
Code Reading Connectors and Locations	54
SCS mode.....	56
Code Type	57
Manual Code Reading (1986–91) ECM LED ONLY	59
Testing ABS.....	60
ABS Codes and Data Testing	60
Manual Code Reading	62
Code Clearing for 1996–2002 Passport with Rear Wheel ABS	65
Code Clearing for 1996–2002 Passport with 4-Wheel ABS.....	65
Testing Supplemental Restraint Systems (SRS).....	66
SRS Main Menu	66
Manual Code Reading	67
Code Clearing	71
Chapter 9: Hyundai.....	77
Testing Engine, Transmission, ABS, and SRS.....	77
Code Reading Connectors and Locations	77
Clearing Codes	79
Actuator Tests.....	79

Chapter 10: Isuzu	80
Testing Engine and Transmission Systems	80
Engine And Transmission Code Reading Connectors and Locations	80
Manual Code reading (Engine)	86
Clearing Codes	87
Road Test (No C&D).....	87
Field Service Functional Tests	88
Testing Antilock Brake System (ABS)	88
ABS Code Reading Connectors and Locations	88
Manual Code Reading (ABS).....	90
Clearing ABS Codes	93
Testing Supplemental Restraint Systems (SRS).....	93
Manual Code Reading (SRS).....	94
Clearing SRS Codes	97
Testing Transfer Case, Body Control Module (BCM), and Instrument Panel Cluster (IPC) Control Systems.....	97
 Chapter 11: Kia	 98
Testing Engine, Transmission, and Antilock Brake Systems	98
Code Reading	98
Manual ABS Code Reading	101
 Chapter 12: Mazda	 102
Testing Engine and Transmission Systems	102
Code Reading	102
Manual Code Reading	103
Functional Tests—1983–95 models.....	104
Functional Tests—All models with EEC-IV and EEC-V systems	105
Transmission Code Retrieval—1987 626	110
Testing Antilock Brake Systems	111
ABS Main Menu	113
Testing Airbag, Transfer Case, and Body Module Systems through the 16 Pin Connector.	116
 Chapter 13: Mitsubishi	 117
Testing Engine, Transmission, ABS, and SRS.....	117
Code Reading Connectors and Locations	117
Supplemental Restraint System (SRS) Code Reading	120
Transmission Manual Code Reading.....	121
ABS Manual Code Reading	121
Codes and Data (Slow)	122
Clearing Codes	122
Actuator Tests.....	122
 Chapter 14: Nissan and Infiniti	 124
Testing Engine Systems.....	124
Code Reading Connectors and Locations	124
Code Types 07	125
Functional Tests.....	129
Testing Transmission Systems.....	132
Nissan 4EAT Transmission Testing.....	133
Testing Antilock Brake Systems (ABS)	134
Code Reading Connectors and Locations	134
Manual Codes	135

Actuator Tests	135
Testing Supplemental Restraint Systems (SRS).....	135
Manual Code Reading	135
Testing Body Control Module (BCM) Systems	137
Testing Controller Area Network (CAN) Systems.....	137
Chapter 15: Subaru	143
Testing Engine Systems.....	143
Code Reading Connector Locations	143
Connecting the Scan Tool to the Vehicle	148
Reading Engine Codes	150
D-Check and Read Memory Connector Locations.....	166
Automatic Code Reading	172
Code Type 08	176
Testing Transmission Systems.....	180
Transmission Code Reading.....	180
1987–92 4EAT Transmission (Version 1)	181
1990–96 4EAT Transmission (Version 2)	181
1990-96 4EAT Transmission (Version 2) History Codes	182
1989-94 Justy ECVT Transmission.....	183
1996-06 Subaru Models with an OBD-II 16-pin Connector.....	184
Testing ABS Systems	184
ABS Code Information	184
ABS Code Types	184
ABS Code Reading and Connector Locations	185
Testing Airbag (SRS) Systems.....	191
Airbag (SRS) Code Information	192
Airbag (SRS) Code Types.....	192
Airbag (SRS) Code Reading and Connector Locations	192
Chapter 16: Toyota, Lexus, and Scion	197
Identifying 1995 and Earlier Vehicles	197
Testing Engine Systems.....	197
Code Reading Connectors and Locations	198
Code Sensitivity—OBD-II and some Pre-OBD-II	199
Data (No Codes)	199
Manual Code Reading	200
Actuator Tests	200
Testing Transmission Systems.....	201
Code Reading Connectors.....	201
Testing ABS Systems	202
Code Reading Connectors.....	202
Testing Supplemental Restraint Systems (SRS).....	203
Reading SRS Codes	203
Code Clearing	204
Chapter 17: Generic OBD-II	207
OBD-II and What it Means.....	207
Selecting The Generic Test Mode	208
Connecting To The Vehicle	208
Main Menu Selections	209
Codes and Data Menu	209

Chapter 18: Data Parameters	214
Interpreting Pressure Parameters	215
Alphabetic List of Parameters.....	216
Antilock Brake System (ABS) Parameters	278
Airbag (SRS) Parameters.....	294
Air Conditioning (A/C) Parameters	297
Body Control Module (BCM) Parameters	300
Engine Parameters.....	334
Generic OBD-II Parameters	456
Hybrid HV ECU and Battery System Parameters.....	465
OBD-II Readiness Monitors.....	473
Occupant Classification (OCC) Parameters	475
Instrument Panel Cluster (IPC) Parameters	476
Tire Pressure Monitor Parameters	482
Transfer Case Parameters	484
Transmission Parameters.....	488
Appendix A: Troubleshooting	523
Slow Codes for Many 1988 and Later Mitsubishi, Chrysler Imports, and Hyundai Sonata ..	523
Codes and Data for 1989 and Later Toyota Cressida and Lexus LS400	523
1996-2006 Mazda 16 Pin DLC Voltage Chart	523
No Communication for 1987–90 Nissan.....	524
GM Control Systems on Isuzu and Isuzu-built Geo.....	525
Glossary	528
Index	536

This manual contains instructions for testing BMW vehicles. Some of the Illustrations shown in this manual may contain modules and optional equipment that are not included on your system. Contact a Snap-on Sales Representative for availability of other modules and optional equipment.

1.1 Conventions

This manual uses the conventions described below.

1.1.1 Bold Text

Bold text is used for emphasis and to highlight selectable items such as buttons and menu options.

Example:

- Select **OK** to continue.

1.1.2 Terminology

Certain terms are used to command specific actions throughout this manual. Those terms are described below.

Select

The term “select” means to highlight a menu item or other option, then pressing the **Y/✓**, **OK**, **Accept**, or similar button to activate it.

Example:

- Select **Functional Tests**.

Scroll

The term “scroll” means moving the cursor or changing data by using the directional arrow buttons, scroll bars, or other means.

Example:

- Scroll to see any other codes and the data list.

Scan Tool

The term “scan tool” will be used to refer to any tool that communicates directly with the vehicle data stream. When necessary, the term “Scanner” is used to distinguish Snap-on equipment from another diagnostic device, such as the BMW factory scan tool.

1.2 Notes and Important Messages

The following messages appear throughout this manual.

1.2.1 Notes

A NOTE provides helpful information such as explanations, tips, and comments.

Example:

**NOTE:**

For additional information refer to...

1.2.2 Important

IMPORTANT indicates a situation which, if not avoided, may result in damage to the test equipment or vehicle.

Example:

IMPORTANT:

To avoid incorrect TPS adjustment or component damage, be sure to follow the on-screen instructions. Refer to a vehicle service manual for complete test or adjustment procedures.

The Asian Import Vehicle Communication Software (VCS) allows you to test multiple vehicle systems: engine, transmission, ABS and airbag (SRS). The functional and component tests offered by the software allow for simplified diagnostics and troubleshooting.

The Asian Import VCS establishes a data link between the scan tool and the electronic control systems of the vehicle being serviced. This data link allows you to view diagnostic trouble codes (DTCs), serial data and freeze-frame information available from the electronic control module (ECM). On models with bi-directional communication, the VCS also lets you perform certain system and component tests and provides the ability to switch off the malfunction indicator lamp (MIL) after repairs are made.

The amount and type of information and tests available with the Asian Import VCS varies by the year, make, model and equipment options of the test vehicle. With the software you can: interpret electronic control module trouble codes, read input and output signals, test specific systems and components, check the operation of certain actuators (solenoids, valves, and relays), and record and view data movies. Manufacturer specific sections feature detailed locations of hard to find connectors and information on manual code reading. This manual also includes chapters on data parameters, OBD-II data parameters, and scan tool specific troubleshooting advice.

The first two sections of this manual overview safety and usage conventions. The remainder of this manual is divided into the following chapters:

- “Chapter 3: Operations” offers general software operating explanations and procedures.
- Chapters 4–16 offer testing information and procedures for control systems of the following manufacturers:
 - Chapter 4: Acura
 - Chapter 5: Chrysler Imports
 - Chapter 6: Daihatsu
 - Chapter 7: Geo
 - Chapter 8: Honda
 - Chapter 9: Hyundai
 - Chapter 10: Isuzu
 - Chapter 11: Kia
 - Chapter 12: Mazda
 - Chapter 13: Mitsubishi
 - Chapter 14: Nissan/Infiniti
 - Chapter 15: Subaru
 - Chapter 16: Toyota/Lexus/Scion
- “Chapter 17: Generic OBD-II Operations” provides information about testing in the Generic OBD-II Test Mode.
- “Chapter 18: Data Parameters” provides definitions for data parameters.
- “Appendix A: Other Software Available” lists the other software titles available from Snap-on.
- “Appendix B: Troubleshooting” offers advice for troubleshooting scan tool-to-vehicle communication and other issues.
- “Glossary of Terms” lists terms and acronyms used in this manual and in Asian Import manufacturer’s literature.

This section explains how to begin using basic scan tool setup and test functions. This information is specific to Asian Import vehicles. For general scan tool functionality, see the user manual appropriate to your diagnostic tool. Figure 3-1 outlines the workflow of using the VCS software.

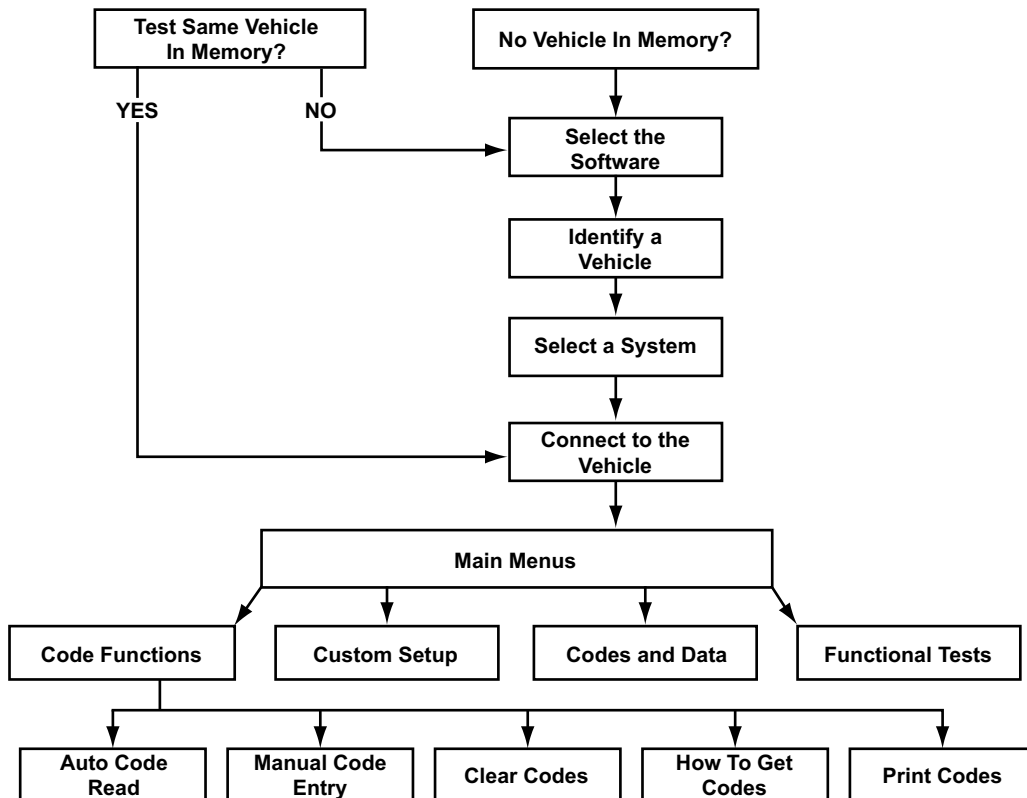

Figure 3-1 Basic Asian Import scan tool test operation



NOTE:

The exact order of test operation steps may vary depending on the test vehicle. Be sure to follow all on-screen instructions.

3.1 Selecting the Software

The first step in testing with the Vehicle Communication Software (VCS) is selecting the correct software for your test vehicle.

Two types of screens display when you turn on your scan tool:

- The **initial menu** displays if you do not have a vehicle in memory.
- The **Current Vehicle ID screen** displays if you have a vehicle in memory.

**To select the software from the initial menu:**

1. Select **Asian** from the Vehicle Communication menu.
The software loads for a moment and then the Software Confirmation screen displays.
2. Select to confirm the software.
The Manufacturer Selection menu displays.
3. Select the manufacturer of the test vehicle from the list.

**To select the software from the Current Vehicle ID screen:**

1. Select to accept if you want to test the same vehicle, or press select cancel if you want to test a different vehicle.
 - The System Selection menu displays if the same vehicle was selected.
 - The Software Confirmation screen displays if you selected to cancel.
2. Follow the on-screen instructions to continue.

3.2 Identifying a Vehicle

After you have selected the software, you are prompted to identify the test vehicle by entering vehicle identification number (VIN) characters and answering questions.

**NOTE:**

Because of midyear manufacturing changes in engine computer systems, you should always enter a new identification when you test a different vehicle, even when two vehicles are the same year, model, and have the same engine and accessories installed.

**To identify a vehicle:**

1. From the Manufacturer Selection menu, select the vehicle manufacturer.
The first in a series of Vehicle Identification screens displays.
2. Scroll and select to enter VIN characters, and answer any questions.
When you are finished, a Vehicle ID Confirmation screen displays.
3. Select to continue if the vehicle ID is correct.
The System Selection menu or Connection Instruction screen displays.

3.3 Selecting a System

A System Selection menu prompts you to select which vehicle control system to test. Menus vary by manufacturer and model. Refer to the manufacturer-specific chapters of this manual for instructions on selecting a system to test.

3.4 Connecting to the Vehicle

A Connection Instruction screen tells you how to connect the supplied vehicle test adapters to the test vehicle you identified.

Each test adapter plugs into a specific vehicle diagnostic connector and attaches to one end of the data cable. The other end of the data cable attaches to the scan tool.

The following adapters are available to connect the scan tool to Asian Import vehicles. See the manufacturer-specific chapters of this manual for connector locations.

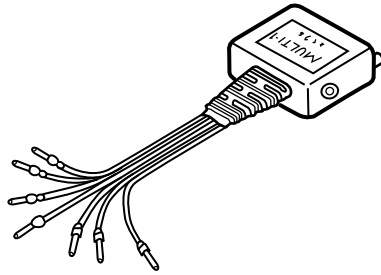

Figure 3-2 MULTI-1 adapter

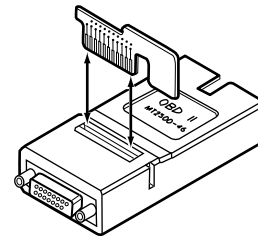

Figure 3-3 OBD-II adapter with Personality Key™

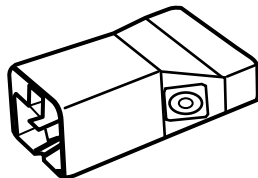

Figure 3-4 TOYOTA-1 adapter

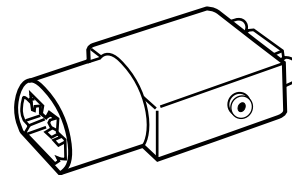

Figure 3-5 TOYOTA-2 adapter, MAZDA-1 adapter

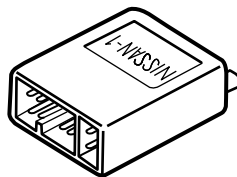

Figure 3-6 NISSAN-1 adapter (12-pin)

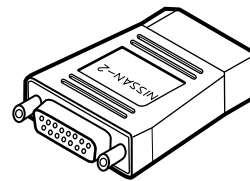

Figure 3-7 NISSAN-2 adapter (16-pin)

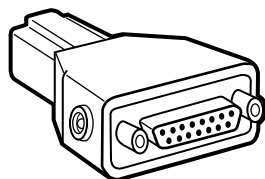

Figure 3-8 HON-1 adapter

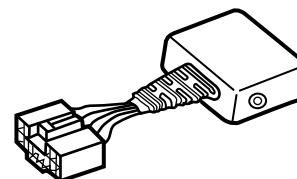

Figure 3-9 HYUNDAI-2 adapter

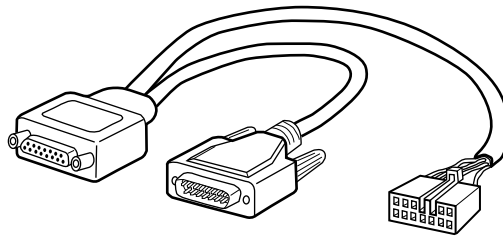

Figure 3-10 MITSU-1 adapter

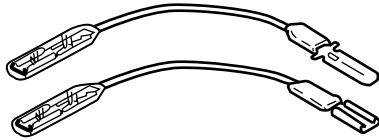

Figure 3-11 Terminal Converters

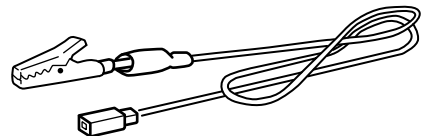

Figure 3-12 Ground adapter

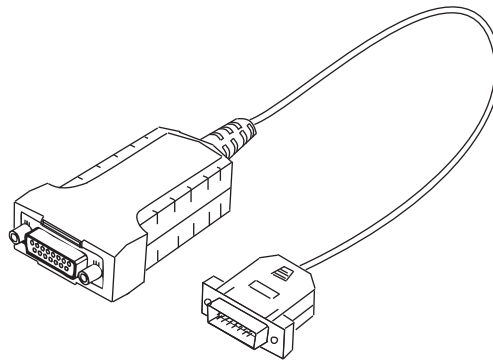
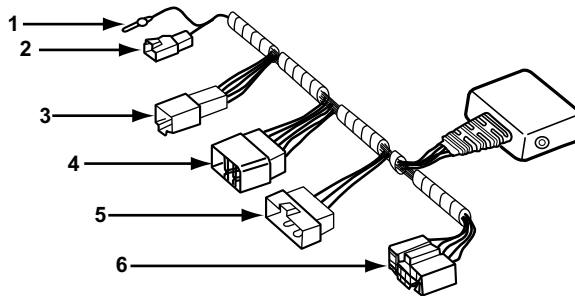

Figure 3-13 CAN1B adapter



- 1— Ground
- 2— Mazda & Ford (2E)
- 3— Isuzu & Geo with GM system (2D)
- 4— Subaru (2C)
- 5— Mazda & Ford (2B)
- 6— Special applications (2A)

Figure 3-14 MULTI-2 Asian adapter

Follow the on-screen instructions to connect the scan tool to the vehicle. Then, select to continue and the Main menu for the identified vehicle displays.

3.5 Main Menu Selections

Depending on the vehicle, the following main menu options may be available:

- **Code Functions** lets you read and interpret electronic control module (ECM) diagnostic trouble codes (DTCs).
- **Codes and Data** lets you read input and output signals if applicable (switches, sensors, and actuators). See the manufacturer sections of the manual for specific information.
- **Functional Tests** provides specific subsystem and component tests. Tests vary by make and model, see the manufacturer-specific sections of the manual for specifics.
- **Actuator Tests** lets you check the operation of certain actuators, such as solenoid valves and relays. Tests vary by make and model, see the manufacturer-specific sections of the manual for specifics.
- **Custom Setup** lets you customize certain scan tool functions. See the manual for your diagnostic tool for details.
- **Movies** lets you record and view data. See the manual for your diagnostic tool for details.

3.6 Code Functions

Selecting Code Functions displays the Code Functions menu.

Depending on the vehicle type, six primary Code Functions selections may be available:

- **Auto Code Read** reads all available electronic codes automatically.
- **How To Get Codes** helps you to locate the test connectors or code lamps for getting codes, and helps you identify the code type.
- **Clear Codes** clears (erases) trouble codes from the vehicle ECM memory.
- **Print Codes** prints selected trouble code definitions.
- **Manual Code Entry** lets you read codes that can be identified by visual observation of a flashing lamp (LED) and manually entering data into the scan tool.
- **Review Codes** lets you review codes stored in scan tool memory, either through automatic code reading or manual code entry.

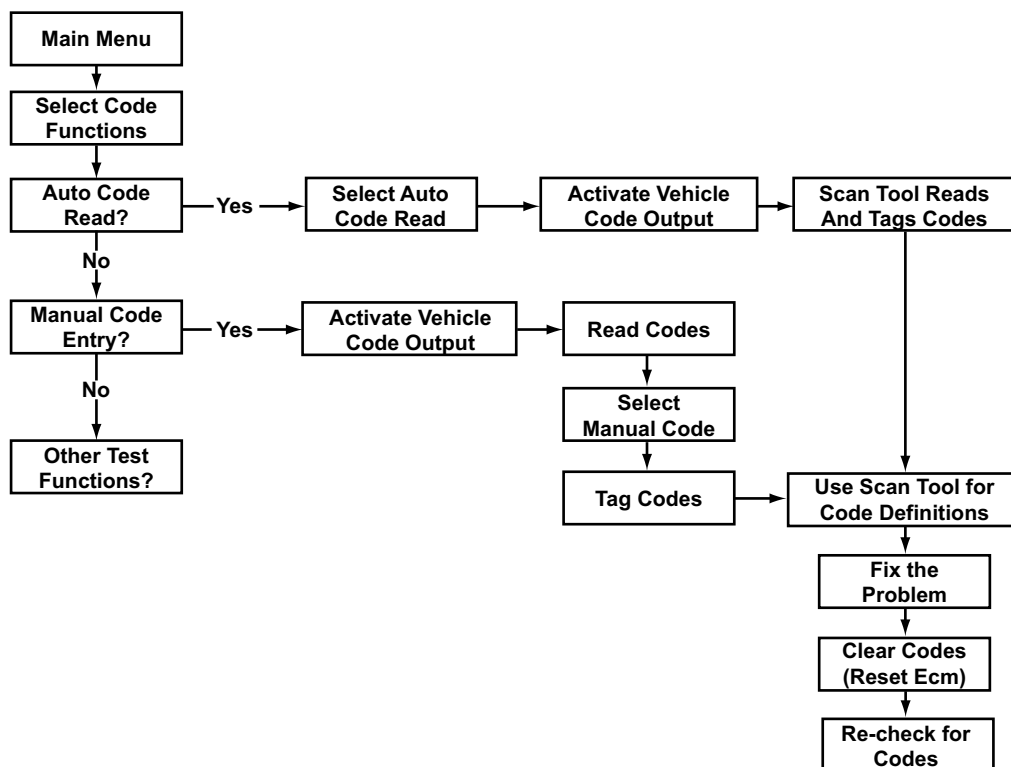

Figure 3-15 Basic Code Functions: Auto Code Read and Manual Code Entry

3.6.1 Reading Different Code Types

Depending on the vehicle, the diagnostic connector may have automatic code reading or you may have to read codes by observing a flashing lamp (LEDs). After you enter the vehicle ID, the scan tool tells you which type of system is on the vehicle you are testing.

For vehicles with diagnostic connectors that have automatic code reading (Auto Code Read), connection instructions for code reading display at the end of the vehicle ID sequence. Instructions for activating flash codes are available by selecting How To Get Codes.

Flash Codes

Different types of code pulse patterns are used by different manufacturers for different models. When a vehicle has indicator lamps (LEDs) that flash trouble codes, the scan tool gives you the code type used for the vehicle you are testing and brief description of the code flashing pattern.

Five general code patterns are used:

- **Straight Count**—flashes the lamp or LED the number of times equal to the trouble code with a noticeable pause between multiple codes.
For example, eight equal flashes is Code 8.
- **Tens/Ones**—flashes a 2-digit trouble code with a noticeable pause between each digit. The first set of flashes is the 10s digit; the second set of flashes is the 1s digit.
For example, Flash–Flash–pause–Flash–Flash–Flash is Code 23.

- **Long/Short**—flashes a 2-digit trouble code with the 10s digit pulses staying on longer than the 1s digit pulses.
For example, Long–Long–pause–Short–Short–Short is Code 23.
- **Main code and Sub-code**—main code will flash first, then pause. Sub-code will follow.
- **4-LED**—turns on one-to-four LEDs to display a binary code. The LEDs stay on until the code is cleared.
- **2-LED**—flashes a 2-digit trouble code with the 10s digit flashed on one LED and the 1s digit flashed on the other LED.

3.6.2 Automatic Code Reading

Selecting Auto Code Read from the Code Functions menu displays a “gathering codes” or “incoming codes”. LEDs flash simultaneously as the codes are received by the scan tool.

**NOTE:**

Some vehicles transmit codes very slowly. Allow several seconds after receiving any code to ensure that no more codes follow.

3.6.3 Clearing Codes

The Clear Codes selection is available from the Code Functions menu after codes have been received. Selecting Clear Codes provides specific information for clearing ECM trouble codes.

Trouble codes are often cleared by removing the battery ground cable or removing a fuse. In some cases however, the Auto Code Read function lets the scan tool clear codes automatically. Select from the menu and follow the on-screen instructions for automatic code clearing.

**NOTE:**

If the vehicle ECM does not receive the code-clearing command, the “Clearing Codes” message stays on the screen indefinitely.

3.6.4 Printing Codes

See the manual for your diagnostic tool for information about setting up a printer.

3.6.5 Manual Code Entry

If you are testing a vehicle that can only display codes manually, you receive connection instructions from the Connection Instruction screen.

Select How To Get Codes from the Code Function menu to see on-screen instructions about reading manual codes from the vehicle you are testing.

3.6.6 How to Get Codes

Selecting How To Get Codes gives instructions for observing codes manually or automatically, depending on the vehicle. The on-screen instructions are supplemented in the manufacturer-specific chapters of this manual.

3.6.7 Reviewing Codes

The Review Codes selection is only available after the scan tool has received codes from manual code entry. Selecting Review Codes displays a screen that lists all codes in memory.

This chapter contains information for testing Acura vehicles with the Asian Import Vehicle Communication Software (VCS). The following Acura systems may be available for testing:

- Engine
- Transmission
- Antilock Brake System (ABS)
- Airbag (SRS)

4.1 Testing Engine Systems

Acura engine system testing includes:

- “Code Reading Connectors and Locations” on page 12
- “ECM Locations 1986 to 1990 with ECM LED” on page 14
- “SCS mode” on page 16
- “Code Type” on page 17
- “Manual Code Reading (Engine Codes)” on page 17
- “Multiple Codes” on page 18

4.1.1 Code Reading Connectors and Locations

Refer to Figure 4-1 for common diagnostic connector locations for Acura vehicles. Connector configurations are shown in Figure 4-2, Figure 4-3 and Figure 4-4.

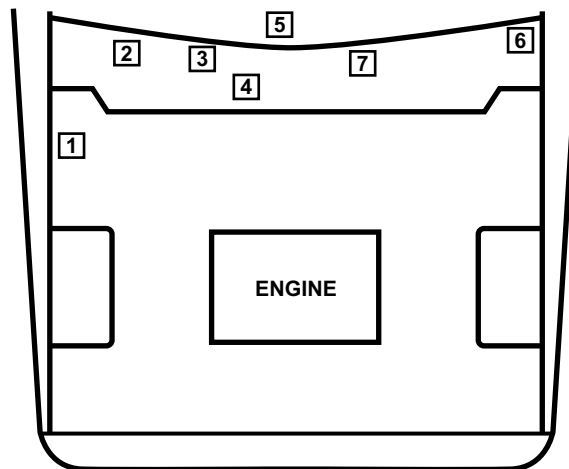

Figure 4-1 Common connector locations

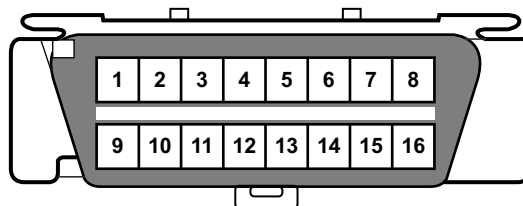

Figure 4-2 OBD-II data link connector (DLC)

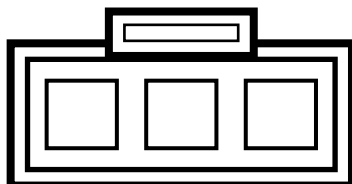

Figure 4-3 3-pin DLC

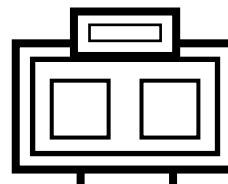

Figure 4-4 2-pin service check signal (SCS) connector

Refer Table 4-1 to determine which adapter to use to test a specific model.

Table 4-1 Common connector locations

VEHICLE	YEAR	SCS 2-PIN	DLC 3-PIN	DLC 16-PIN
2.2 CL	1997	3		5*
2.3 CL	1998–99	3		5*
2.5 TL	1995–98	2		5*
3.0 CL	1997–99	3		5*
3.2 CL	2001–02			5*
	2003			7
3.2 TL	1996–98	2		5*
	1999–2002			5*
	2003			7
3.5 RL	1996–2003	2		5*
Integra	1992–95	1	1	
	1996–2001	1		4
MDX	2001–04			7
NSX	1995–2003	1		3*
RSX	2002–04			7
SLX	1996–99			6**
3.2 TL	2004			6
NSX	2004	2		3
TSX	2004			6
3.5 RL	2004	3		5*

* Remove ashtray

** Remove the DLC cover

4.1.2 ECM Locations 1986 to 1990 with ECM LED

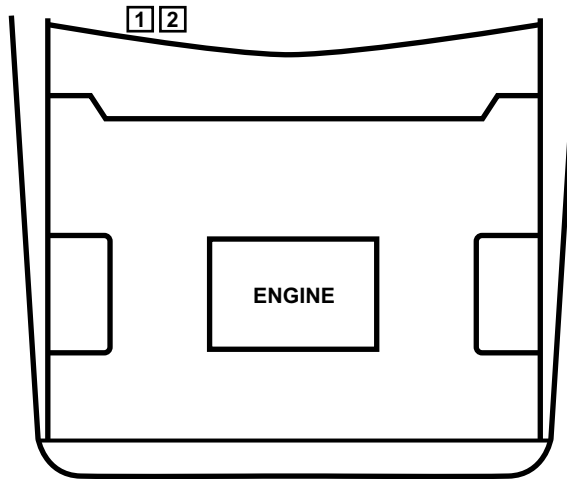
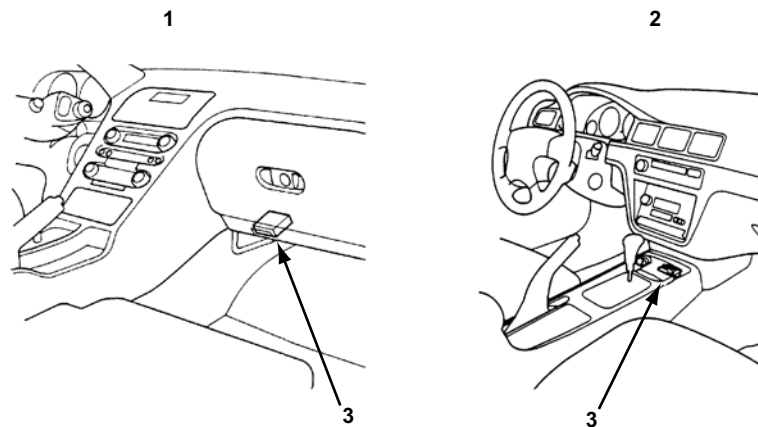

Figure 4-5 LED Locations.

Table 4-2 LED locations

VEHICLE	YEAR	LED LOCATION
Integra	1986–89	1
Legend Sedan	1986–90	2



1— 1995 2.5, 3.2 TL

2— 1995 NSX

3— 16-pin Data Link Connector (DLC)—Use OBD-II adapter.

Figure 4-6 Acura data link connector (DLC) locations

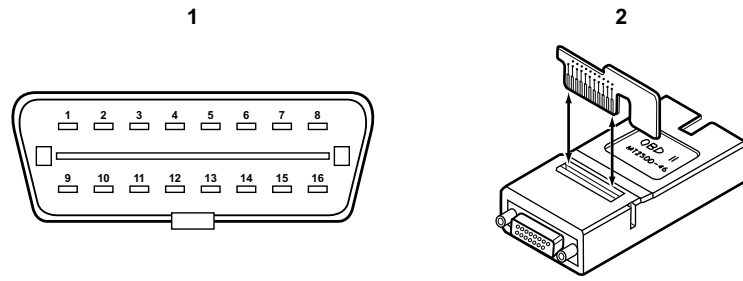

- 1— 16-pin DLC
- 2— OBD-II adapter

Figure 4-7 Acura DLC and adapter

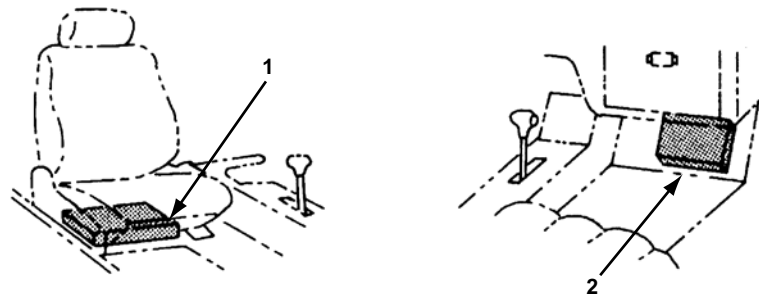

- 1— 1986-89 Integra, 1986-90 Legend Sedan
- 2— 1990-91 Integra, 1987-90 Legend Coupe

Figure 4-8 Acura control module locations for LED code flashers

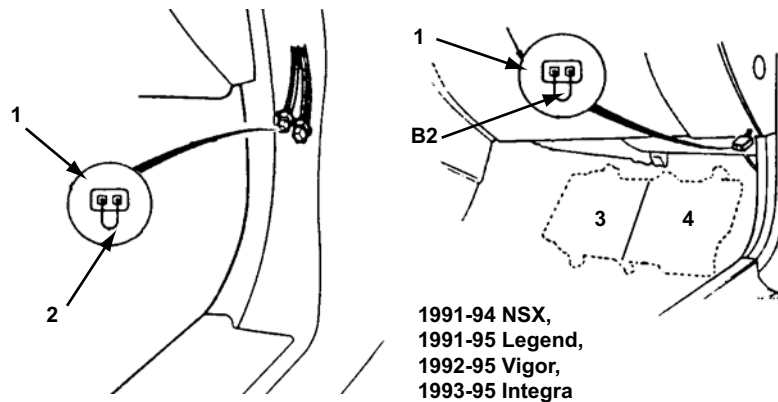

1991-94 NSX,
1991-95 Legend,
1992-95 Vigor,
1993-95 Integra

- 1— Service check connector
- 2— Jump wire
- 3— ECM
- 4— TCM

Figure 4-9 Acura check connector locations for Check Engine Lamp code flashers

4.1.3 SCS mode

Purpose of SCS (Service Check Signal) mode:

- Enables a diagnostic mode
- Flash out DTCs stored for the PCM, ABS, TCS, and SRS modules
- Code clearing on certain ABS systems
- Bypass two trip detection mode for OBD-II drive cycles



NOTE:

Certain OBD-II vehicles use a separate 2 pin SCS connector. Other OBD-II models use a SCS pin in the 16 PIN DLC. Both function the same way. For specific applications, refer to “Code Reading Connectors and Locations” on page 12.

Models with a separate 2 pin SCS connector:

Acura tool 07PAZ-0010100, or equivalent, is used to jump the 2-pin SCS connector. With the SCS jumped, the ABS lamp flashes a Type 4 code once per ignition cycle.

Models with the SCS in the 16 pin DLC:

The scan tool grounds the appropriate pin of the DLC, which enables the SCS mode. Follow the on-screen instructions.



NOTE:

The K-18 key must be used for SCS mode.

The SCS help briefly explains the two trip bypass operation (PCM only, see the section on “Two-trip detection bypass”

ABS code clearing using SCS mode (certain 1997 and later models)

When instructed by the scanner, ABS codes may be cleared using the SCS mode.

Airbag code reading message (typical, using SCS mode)

The SCS mode can be used to retrieve airbag codes, which flash as a Type 6 code on the SRS lamp. Follow the on-screen instructions. Airbag codes are cleared using the message erase signal (MES) connector located in the fuse box.



NOTE:

The MES connector is not the same as the SCS connector.

Two-trip detection bypass

Use SCS mode to bypass ODB 'two trip detection' and re-create certain DTCs during diagnosis. Some codes require a back driving sequence (two road tests) where the fault must occur in a similar operating condition.



NOTE:

On OBD-II vehicles with the separate 2 pin SCS connector, jumper the 2 pin connector for the SCS mode functions.

A DTC can be captured in one driving event by connecting the scanner and selecting 'SCS' mode from the main menu (on applicable vehicles). For scan data usage during SCS mode, manually jump the DLC from the backside while the scanner is connected to the DLC.

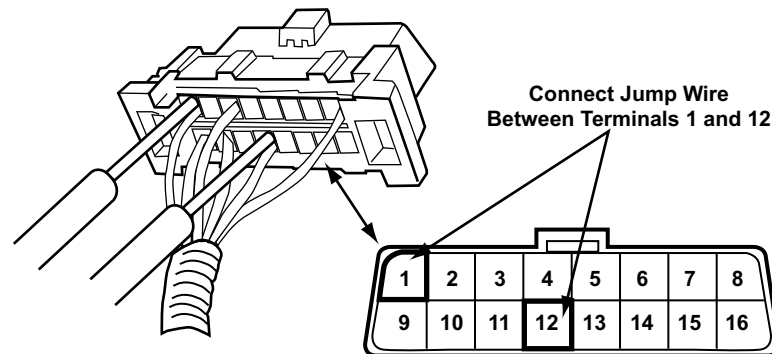

Figure 4-10 Data connector from the wire side (Honda numbering, not the same as SAE)

4.1.4 Code Type

For those systems that rely on manual code reading, you must interpret a DTC from a flashing indicator lamp. The code flash sequence varies by model and system. The Scanner™ therefore refers you to a certain 'code type' (for example Code Type 03). Code type is a specific labeling system that identifies the appropriate section in this manual for each subsystem.

4.1.5 Manual Code Reading (Engine Codes)

There are 2 types of manual engine codes:

- Type 02, see Figure 4-11 and Table 4-3
- Type 03, see Figure 4-12 and Table 4-4

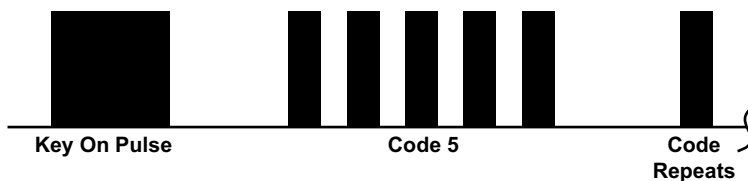

Figure 4-11 Acura engine Code Type 02

Table 4-3 Acura engine Code Type 02

Pattern:	Long and short
Read codes on:	Red LED on ECU
Start codes by:	Turn the ignition on.
When done:	Turn the ignition off and clear codes.
Only one code displays at a time except on some late-model cars. After repairs, clear codes and test drive, then check for other codes.	

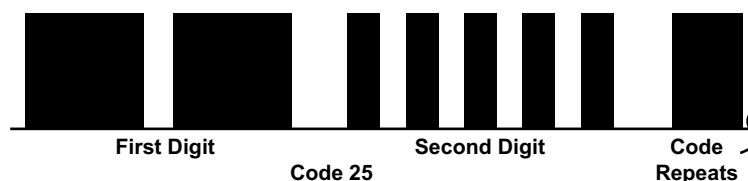

Figure 4-12 Acura engine Code Type 03

Table 4-4 Acura engine Code Type 03

Pattern:	Long and short
Read codes on:	Red LED on ECM; except most 1991 and later flash codes on CHECK engine lamp on dash
Start codes by:	Turn the ignition on; except most 1991 and later, jumper the check connector, then turn the ignition on.
When done:	Turn the ignition off and clear codes.
Only one code displays at a time except on some late-model cars. After repairs, clear codes and test drive, then check for other codes.	

4.1.6 Multiple Codes

The 1990 and later Integra and the 1991 Legend and NSX pulse multiple codes with a 2-second pause between each code. All other Acura models, including the 1990 Legend, with an ECM, do not have multiple code memory.



To read codes for vehicles without multiple code capability:

1. Read the trouble code.
2. Fix the problem.
3. Reset the ECM.
4. Drive the vehicle.
5. Check the LED for a new code.
6. Continue until no codes are present.

4.2 Testing Transmission Systems

These instructions for reading manual codes only apply to 2001 and earlier models. 2002 and later models have Codes and Data selections available from the Main Menu.

4.2.1 Code Reading Connector Locations

Figure 4-13 and Figure 4-14 provide diagnostic connector locations and adapter information.

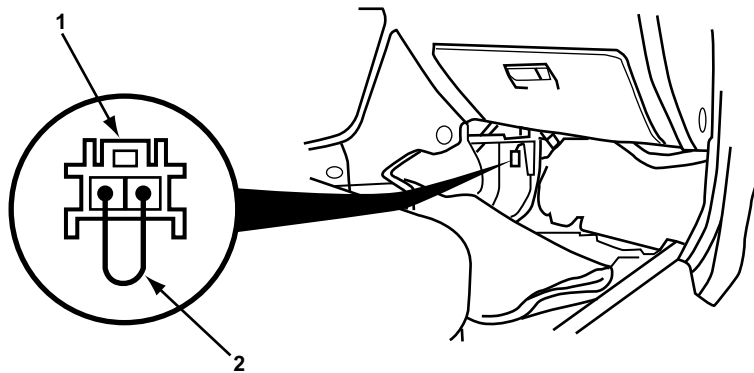

- 1— Service check connector
- 2— Jump wire

Figure 4-13 1991–95 NSX, 1992–95 Vigor transmission service check connector locations

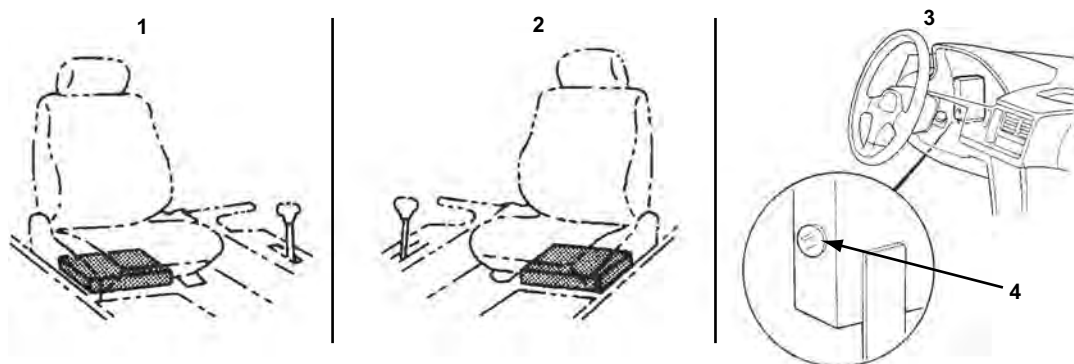

- 1— 1987–90 Legend Coupe
- 2— 1988–90 Legend Sedan
- 3— 1990–95 Integra
- 4— LED display

Figure 4-14 Acura transmission service check connector locations

Figure 4-15 shows common transmission diagnostic connector locations for Acura vehicles.

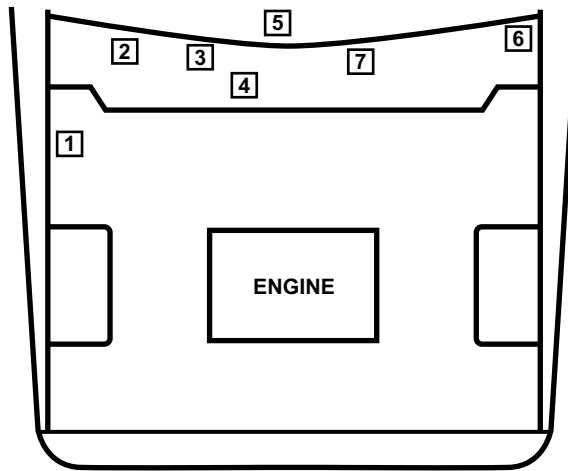

Figure 4-15 Common transmission connector locations for 1995–2003 vehicles

Refer to Table 4-5 to determine which adapter to use to test a specific model.

Table 4-5 Common connector locations

VEHICLE	YEAR	SCS 2-PIN	DLC 3-PIN	DLC 16-PIN
2.2 CL	1997	3		5*
2.3 CL	1998–99	3		5*
2.5 TL	1995–98	2		5*
3.0 CL	1997–99	3		5*
3.2 CL	2001–02			5*
	2003			7
3.2 TL	1996–98	2		5*
	1999–02			5*
	2003			7
3.5 RL	1996–2003	2		5*
Integra	1996–2001	1		4
MDX	2001–04			7
NSX	1995–2003	1		3*
RSX	2002–04			7
SLX	1996–99			6**
TSX	2004			6
3.2 TL	2004			6
NSX-T	2004			3
3.5 RL	2004	3		5*
* Remove ashtray				
** Remove the DLC cover				

**NOTE:**

To retrieve codes with the scan tool, use the 16-pin connector. To retrieve codes manually, use the SCS connector.

4.2.2 Manual Code Reading (Transmission Codes)

There are 2 types of manual transmission codes:

- Type 02, see Figure 4-16 and Table 4-6
- Type 03, see Figure 4-17 and Table 4-7.

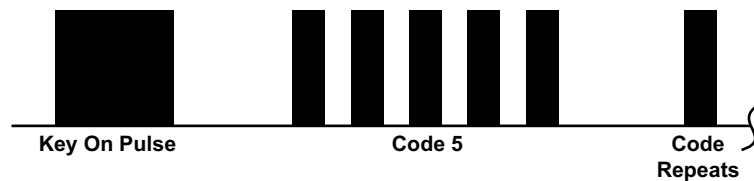

Figure 4-16 Acura transmission Code Type 02

Table 4-6 Acura transmission Code Type 02

Pattern:	Straight count
Read codes on:	Red LED on TCM
Start codes by:	Turn the ignition on.
When done:	Turn the ignition off, then clear codes.
Only one code displays at a time except on some late-model cars. After repairs, clear codes and test drive, then check for other codes.	

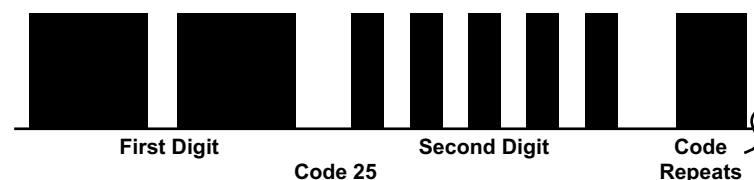

Figure 4-17 Acura transmission Code Type 03

Table 4-7 Acura transmission Code Type 03

Pattern:	Long and short
Read codes on:	Red LED on TCM or gear indicator lamp on dash
Start codes by:	Turn the ignition on; except for 1991 and later Vigor, Legend, and NSX, jumper the check connector, then turn the ignition on.
When done:	Turn the ignition off, then clear codes.
Only one code displays at a time except on some late-model cars. After repairs, clear codes and test drive, then check for other codes.	

4.3 Testing Antilock Brake Systems (ABS)

Acura antilock brake system (ABS) testing includes the following:

- “Code Reading Connectors and Locations” on page 22
- “ABS Codes and Data Testing” on page 23
- “Manual Code Reading (ABS Codes) and Clearing Codes” on page 25

4.3.1 Code Reading Connectors and Locations

Diagnostic connector locations and test adapter information for Acura ABS are shown in Figure 4-18, Figure 4-19 and Figure 4-20.

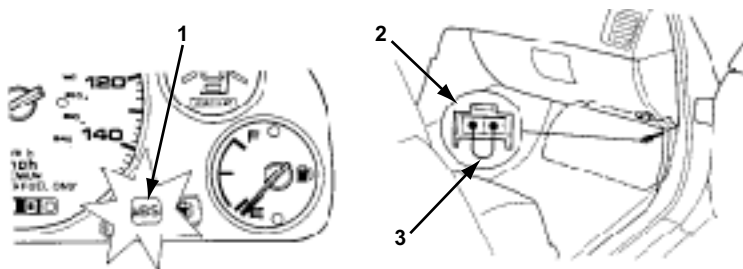

- 1— ABS indicator lamp
- 2— Service check connector
- 3— Jump wire

Figure 4-18 1991–95 NSX, 1992–94 Vigor, 1991–94 Legend ABS controller and service check connector locations

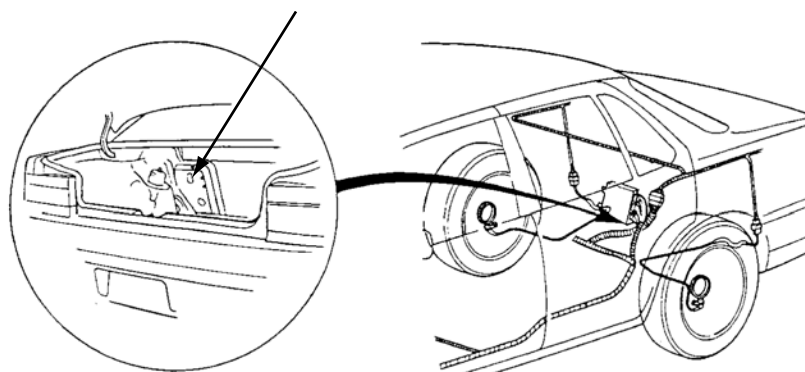
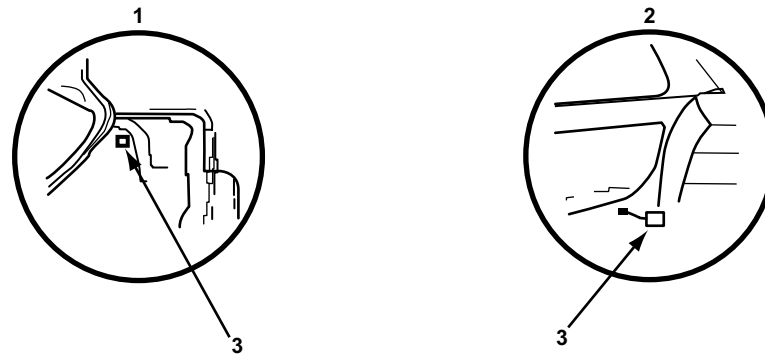
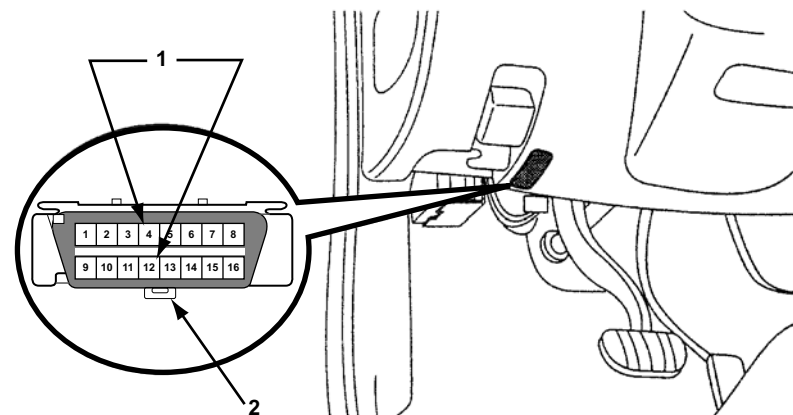

Figure 4-19 1986–90 Legend ABS controller and service check LED location



- 1— 4-door
 2— 3-door
 3— Access cover

Figure 4-20 1990-93 Integra ABS controller and service check connector locations



- 1— Jump pin 4 to pin 12
 2— DLC

Figure 4-21 1996-97 SLX ABS controller and service check connector locations

4.3.2 ABS Codes and Data Testing

The following selections are available for ABS testing:

- “ABS Main Menu” on page 23
- “Codes and Data Menu” on page 24
- “Data (No Codes)” on page 24
- “Codes Only” on page 24
- “Clear Codes” on page 25

ABS Main Menu

After selecting ABS from the System Selection menu, the Main Menu (ABS) is displayed. Selections vary by model and year.

The following main menu selections are discussed:

- “Codes and Data Menu”
- Movies, Custom Setup, and Troubleshooter are discussed in detail in the user manual for your diagnostic tool.

Codes and Data Menu

When Codes and Data Menu is selected, a submenu with the following options displays:

- **Data (No Codes)**—begins communication with the ABS module and displays data parameters.
- **Codes Only**—gathers and displays ABS trouble codes.
- **Clear Codes**—clears ABS memory codes from the ABS ECM memory.
- **Review Codes**—allows you to view codes. (This menu item appears only after code gathering.)
- **Print Codes**—allows you to print codes. (This menu item appears only after code gathering.)

Data (No Codes)

This section has information on viewing ABS data using the scan tool.



To enter and exit ABS data:

1. Enter in the vehicle ID.
2. Turn the ignition on.
3. Select **Data (No Codes)**
4. Turn the ignition off after completing the ABS data tests.

Codes Only

This section has information on retrieving ABS codes using the scan tool.



To gather codes:

1. Select **Codes Only**.
A “key on” verification screen displays. Make sure the ignition is switched on.
2. Select to continue.
An “initializing communication” screen appears while the scan tool establishes communication with the vehicle.



NOTE:

The “initializing communication” screen means the scan tool is attempting to start the test, however it does not mean the vehicle has responded. If the message stays on the screen more than a few minutes, the test did not start.

If no codes are detected during the test a “P0000 no faults present” message displays

3. The Code List, which shows all codes in memory displays if codes are present.

Clear Codes

This section has information on clearing ABS codes using the scan tool.



To clear codes:

1. Select **Clear Codes**.
A “key on” verification screen displays. Make sure the ignition is switched on.
2. Select to continue.
A code clearing confirmation screen displays.
3. Select to clear ABS codes.
4. The DTCs Cleared screen appears,
5. Select to exit.

4.3.3 Manual Code Reading (ABS Codes) and Clearing Codes

There are several types of manual codes for Acura ABS:

- Type 02, see Figure 4-22 and Table 4-8 on page 25
- Type 04, see Figure 4-23 and Table 4-9 on page 26
- Type 5a, see Figure 4-24 and Table 4-10 on page 27
- Type 06, see Figure 4-25 and Table 4-11 on page 27
- Type 12, see Figure 4-26 and Table 4-12 on page 28

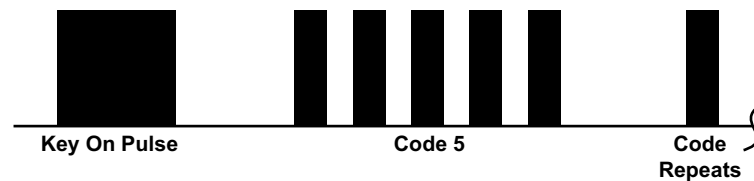

Figure 4-22 Acura ABS Code Type 02

Table 4-8 Acura ABS Code Type 02

Pattern:	Straight count
Read codes on:	ABS lamp on dash
Start codes by:	Jumper the check connector, then turn the ignition on.
When done:	Turn the ignition off, then clear codes.
Only one code displays at a time except on some late-model cars. After repairs, clear codes and test drive, then check for other codes.	

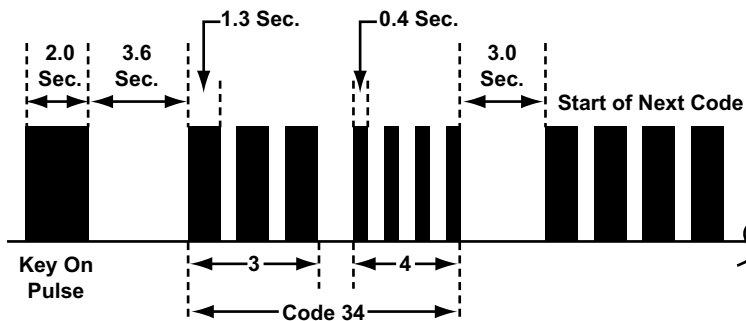

Figure 4-23 Acura ABS Code Type 04

Table 4-9 Acura ABS Code Type 04

Pattern:	10s and 1s
Read codes on:	ABS warning lamp
Start codes by:	<p>For 2003–04 NSX: Short SCS connector and turn key on; (do not press brake pedal). ABS indicator will stay on for 2 seconds then turn off. Main code will flash then pause 0.4 seconds, sub-code will flash and pause 3.6 seconds. If a DTC is not available, the ABS lamp will go off for 3.6 seconds then come back on.</p> <p>For other models: Short SCS connector and turn key on; ABS indicator light will stay on for 2 seconds then turn off; main code will flash then pause 0.4 seconds; sub-code will flash and pause 3.6 seconds; stored codes will flash only one time per ignition cycle; cycle key at least once to verify codes.</p>
Clear codes:	<p>For 2000–02 3.5 RL: Press parking brake pedal; with SCS shorted, hold VSA switch in the off position and turn the ignition on; hold for 3–5 seconds until VSA light blinks 4 times; this signals that codes have been cleared.</p> <p>For 2003-2004 RL: Press parking brake pedal. Push VSA 'OFF' switch, hold it, then turn ignition on. Hold VSA switch for 3-5 seconds, then release VSA switch. After 3 seconds, the VSA indicator should blink 4 times. This signals that the codes have been cleared.</p> <p>For 2003–04 NSX: With the SCS shorted, press the brake pedal and cycle ignition on. After the ABS indicator goes off, release the brake pedal. After the ABS indicator comes back on, depress brake pedal again. After the ABS indicator goes off again, release the brake pedal. After a few seconds the ABS indicator will blink twice and the DTC is cleared. Turn ignition off and un-short the SCS connector.For other models: With the SCS shorted, cycle key on with brake pedal pressed; ABS light will turn on, then shut off; release pedal and light will turn on; press brake pedal until light turns off and release pedal.</p>

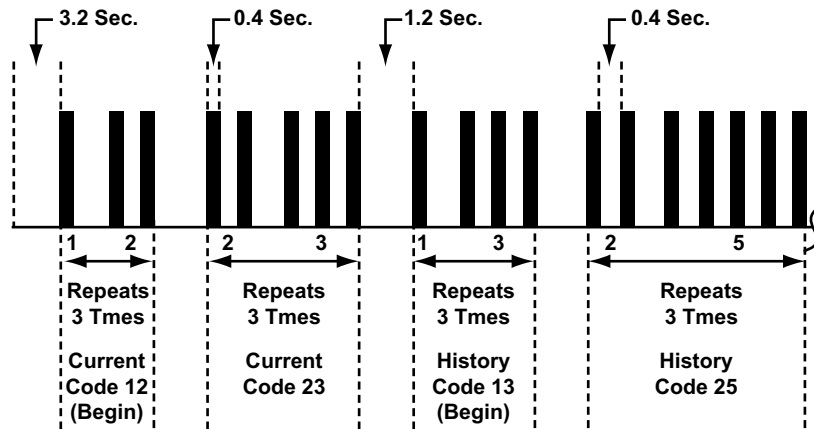

Figure 4-24 Acura ABS Code Type 5a

Table 4-10 Acura ABS Code Type 5a

Pattern:	10s and 1s
Read codes on:	ABS warning lamp
Start codes by:	After bringing the vehicle to a complete stop and making sure the brake pedal is not depressed, turn the ignition switch to the off position. Connect terminals 12 and 4 on the OBD-II 16-pin DLC. Turn the ignition switch to the ON position.
Clear codes by:	Within three seconds after entering the diagnostic mode, pulsate the brake switch on and off at least six times.
When done:	Turn the ignition off, disconnect connectors, then clear codes.
<p>All codes repeat three times and are followed by a 1.2-second pause. Code 12 always flashes first to confirm the system is in the diagnostic mode. Any current codes follow code 12. Code 13 indicates the presence of history codes which then follow. If only history codes are present, the diagnostic sequence will first flash code 12, then code 13, followed by the history codes. The code display cycle repeats as long as the system is in the diagnostic state.</p>	

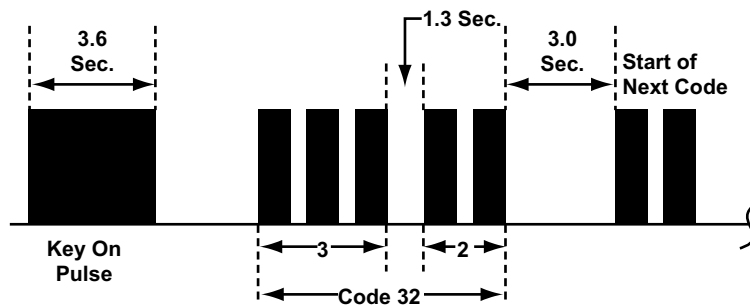

Figure 4-25 Acura ABS Code Type 06

Table 4-11 Acura ABS Code Type 06

Pattern:	Main code and sub-code
Read codes on:	ABS warning lamp
Start codes by:	Short the SCS connector and turn key on; ABS indicator light will stay on for 2 seconds then turn off; main code will flash then pause 1 second; sub-code will flash and pause 5 seconds; stored codes will flash only one time per ignition cycle; cycle key at least once to verify codes.
When done:	To clear codes, remove ABS B2 (15A) fuse in the ABS fuse box for 10 seconds. NSX only: Remove #2 and #3 ABS fuse for 10 seconds.

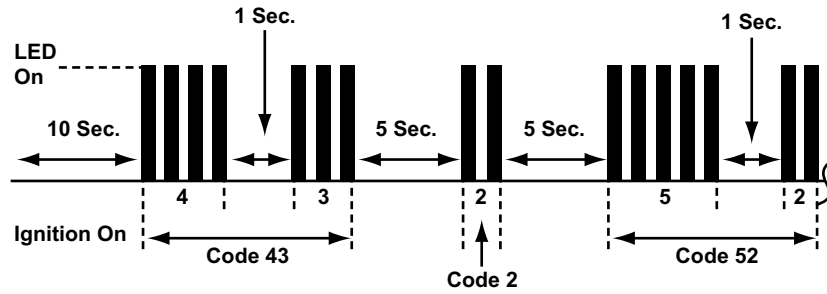

Figure 4-26 Acura ABS Code Type 12

Table 4-12 Acura ABS Code Type 12

Pattern:	Main code and sub-code
Read codes on:	Red LED on antilock brake controller
Start codes by:	Turn the ignition on.
When done:	Turn the ignition off, then clear codes.
Only one code displays at a time except on some late-model cars. After repairs, clear codes and test drive, then check for other codes.	

4.4 Testing Supplemental Restraint Systems (SRS)

Testing Acura supplemental restraint systems (SRS), or airbag systems, includes:

- “SRS Main Menu” on page 28
- “Manual Code Reading (SRS)” on page 29
- “Code Clearing (SRS Codes)” on page 31

4.4.1 SRS Main Menu

After selecting SRS from the System Selection menu, the Main Menu (SRS) displays. Selections vary by model and year.

Codes and Data Menu

When Codes and Data Menu is selected, a menu with the following choices displays

- **Data (No Codes)**—begins communication with the SRS module and displays data parameters.
- **Codes Only**—gathers and displays SRS trouble codes.
- **Clear Codes**—clears SRS memory codes from the SRS ECM memory.
- **Review Codes**—allows you to view codes. (This menu item appears only after code gathering.)
- **Print Codes**—allows you to print codes. (This menu item appears only after code gathering.)

Data (No Codes)

This section has information on viewing SRS data using the scan tool.



To enter and exit SRS data:

1. Enter in the vehicle ID.
2. Turn the ignition on.
3. Select **Data (No Codes)**
4. Turn the ignition off after completing the SRS data tests.

Codes Only

This section has information on retrieving SRS codes using the scan tool.



To gather codes:

1. Select **Codes Only**.
A “key on” verification screen displays. Make sure the ignition is switched on.
2. Select to continue.
An “initializing communication” message displays.



NOTE:

The “initializing communication” screen means the scan tool is attempting to start the test, however it does not mean the vehicle has responded. If the message stays on the screen more than a few minutes, the test did not start.

3. The Code List, which shows all codes in memory displays if codes are present.

Clear Codes

This section has information on clearing SRS codes using the scan tool.



To clear codes:

1. Select **Clear Codes**.
A “key on” verification screen displays. Make sure the ignition is switched on.
2. Select to continue.
3. When the confirmation message displays, select to clear ABS codes.
The DTCs Cleared message displays.
4. Select to exit.

4.4.2 Manual Code Reading (SRS)

There are 2 types of manual SRS codes:

- Type 06, see Figure 4-27 and Table 4-13 on page 30
- Type 07, see Figure 4-28 and Table 4-14 on page 30

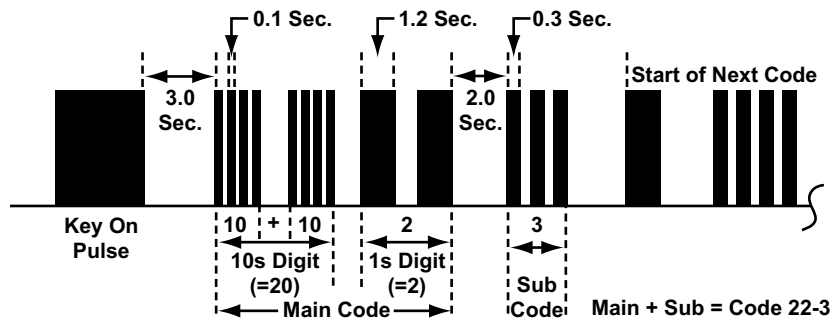

Figure 4-27 Acura SRS Code Type 06

Table 4-13 Acura SRS Code Type 06

Pattern:	Main code and sub-code
Read codes on:	SRS warning lamp
Start codes by:	Short the SCS connector and turn key on; SRS warning lamp will turn on then turn off after 3.0 seconds; if the code is greater than 10, four quick flashes (0.1 seconds each) = 10; main code will flash and pause 2.0 seconds and flash again if code is greater than 1; after a 2.0 second pause, sub-code will now flash in 0.3 second pulses, followed by more flashes if code is greater than 1.
When done:	Clear codes. If the SCS connector is shorted and SRS has no stored DTC, it's normal to see the SRS light remain on continuously.
Computer can store up to 3 most recent codes. The SCS is part of the 16-pin DLC; ground pin #9 to activate. 3.5 RL only: SCS connector is separate from the 16-pin DLC. The 2-pin SCS connector is located under the glove box.	

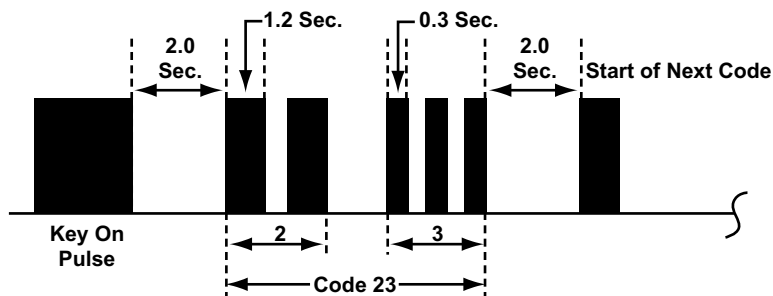

Figure 4-28 Acura SRS Code Type 07

Table 4-14 Acura SRS Code Type 07

Pattern:	Main code and sub-code
Read codes on:	SRS warning lamp
Start codes by:	Short the SCS connector and turn key on; SRS warning lamp will turn on then turn off; after 2.0 seconds, main code will flash, pause 1.2 seconds, and flash again if code is greater than 1; add the flashes together for main code; after a 2.0 second pause, sub-code will now flash in 0.3 second pulses and flash again if code is greater than 1; add the flashes together for sub-code.
When done:	Clear codes.
Computer can store up to 3 most recent codes. If the SCS connector is shorted and SRS has no stored DTC, it's normal to see the SRS light remain on continuously. 1995-96 2.5 TL models are different, if no DTCs are stored, the SRS lamp will flash continuously without pausing.	

4.4.3 Code Clearing (SRS Codes)



To clear DTCs from the SRS unit on all models except SLX and NSX:

1. Switch the ignition off.
 2. Connect the SCS service connector (Acura 07PAZ-0010100) to the yellow 2-pin MES connector (Figure 4-29).
A jumper wire can be used as long as you maintain good contact between the terminals.
 3. Switch the ignition on.
The SRS indicator lamp lights for about 6 seconds, then switches off.
 4. Remove the SCS service connector from the MES connector within 4 seconds of the lamp switching off.
 5. When the SRS indicator lamp lights again, connect the SCS service connector to the MES connector within 4 seconds of the lamp switching on.
 6. When the SRS indicator lamp switches off, remove the SCS service connector from the MES connector within 4 seconds.
 7. Switch the ignition off and wait ten seconds.
- The SRS lamp flashes twice to indicate memory has been erased.

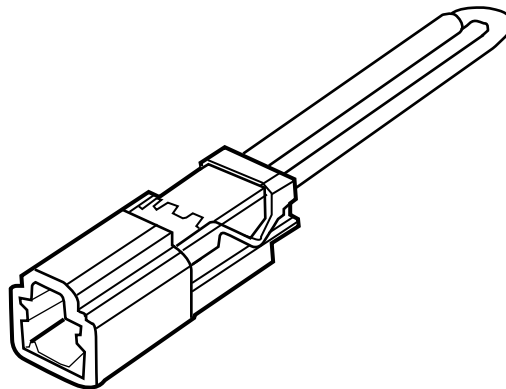
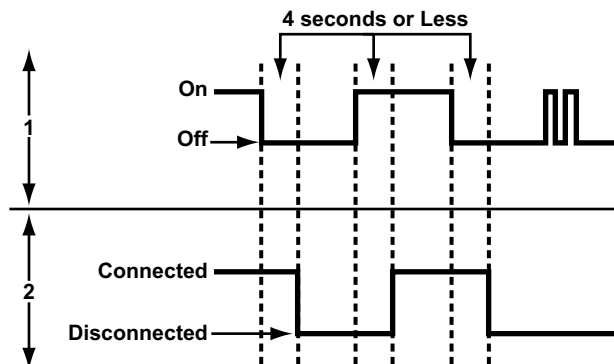
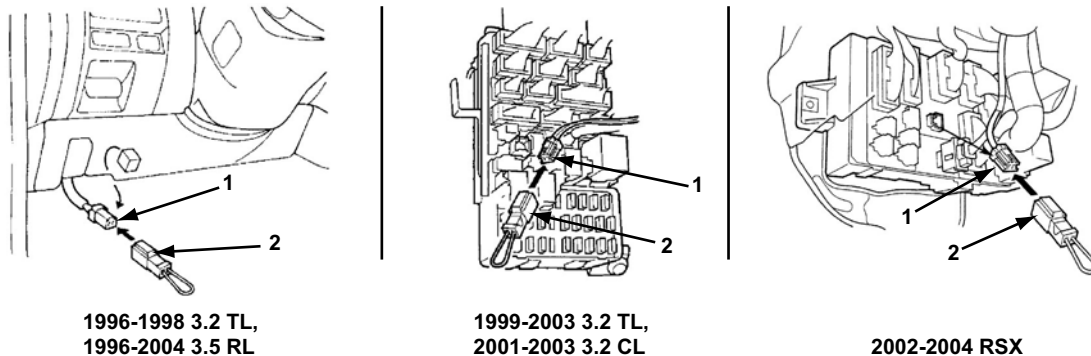

Figure 4-29 SCS Service Connector. Use Acura tool 07PAZ-0010100 (or use jumper wire equivalent)



- 1— SRS indicator lamp
2— MES connector terminals

Figure 4-30 SRS code clearing



- 1— Memory Erase Signal (MES) 2P connector
- 2— SCS Service connector (Acura 07PAZ-0010100)

Figure 4-31 Acura OBD-II SRS MES connector (1 of 2)

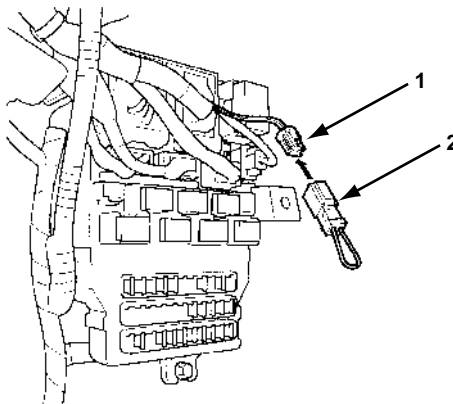

- 1— MES connector
- 2— SCS service connector (Acura 07PAZ-0010100)

Figure 4-32 2004 TSX/TL SRS code clearing (left side of dash)

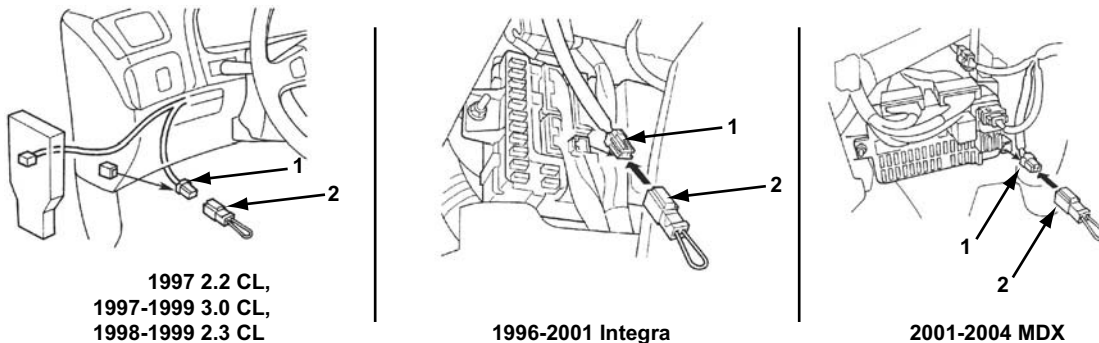

- 1— MES 2P connector
- 2— SCS Service connector (Acura 07PAZ-0010100)

Figure 4-33 Acura OBD-II SRS MES connector location (2 of 2)

This chapter contains information for testing Chrysler Imports vehicles with the Asian Import Vehicle Communication Software (VCS). The following Chrysler Import systems may be available for testing:

- Engine
- Transmission
- Antilock Brake System (ABS)
- Supplemental Restraint System (SRS)

5.1 Testing Engine, Transmission, ABS, and SRS

Chrysler Import testing includes:

- “Code Reading Connectors and Locations” on page 33
- “ABS Manual Code Reading” on page 36
- “Clearing Codes” on page 36
- “Codes and Data (Slow)” on page 37
- “Actuator Tests” on page 37

5.1.1 Code Reading Connectors and Locations

Figure 5-1 below and Table 5-1 on page 34 provide Chrysler Import diagnostic connector location information.

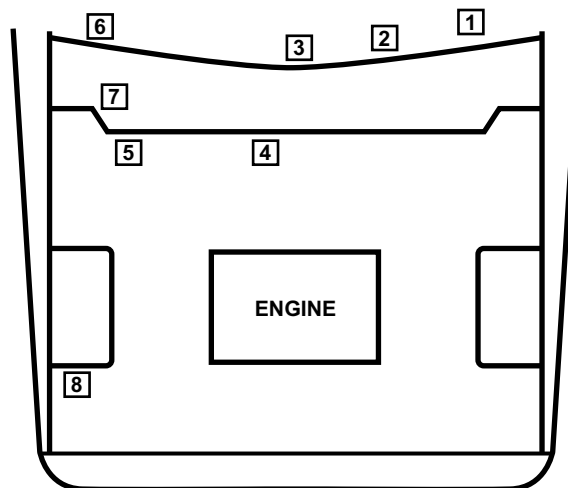

Figure 5-1 Common connector locations

Table 5-1 Common connector locations

VEHICLE	YEAR		LOCATION
Avenger/Sebring	1995–2000	2	Next to console
Colt Turbo	1994–96	5	Near firewall
	1987–88	4	Near firewall
Colt Wagon	1988–90	3	Near ECM at center console
Colt/Summit	1989–96	1	Next to fuse panel
Conquest	1984–86	8	Engine compartment
	1987–89	7	Next to glove box striker
Laser/Talon	1990–94	1	Next to fuse panel
Raider	1989	7	Behind glove box
Stratus Coupe	2004	4	Near firewall
Sebring Coupe	2004	4	Near firewall
Stealth	1991–93	1	Next to fuse panel
	1994–96	2	Next to console
Talon	1995–98	2	Next to console
Truck	1990–94	1	Next to fuse panel
Vista	1987–91	6	Next to latch at lower glove box
Vista/Summit Wagon	1992–96	1	Next to fuse panel

Connectors and adapters for reading Chrysler Import codes are shown in:

- Figure 5-2—Engine codes for most vehicles before 1987
- Figure 5-3—Engine and transmission codes for most OBD-I vehicles after 1988
- Figure 5-4—Airbag (SRS) codes for most 1994 and earlier vehicles
- Figure 5-5—Codes for most OBD-II vehicles with 12-pin and 16-pin connectors

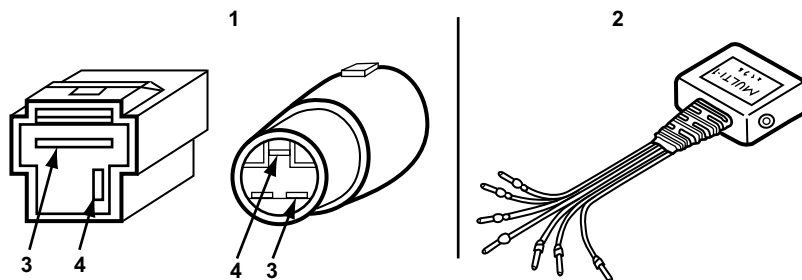

- 1— Connectors**
- 2— MULTI-1 adapter**
- 3— Black**
- 4— Green (preferred) or Yellow**

Figure 5-2 Connectors and adapter for most vehicles before 1987

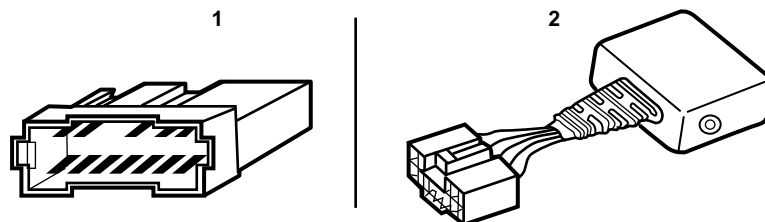
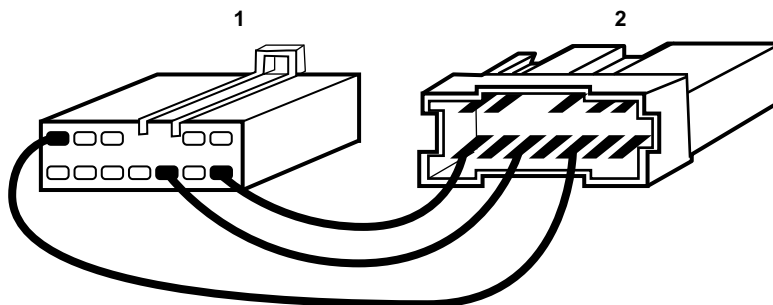

Figure 5-3 Connector and adapter for most OBD-I vehicles

- 1— Connector
- 2— HYUN-2 adapter



- 1— HYUN-2 adapter
- 2— Connector

Figure 5-4 Connector and adapter for SRS system on most 1994 and earlier vehicles

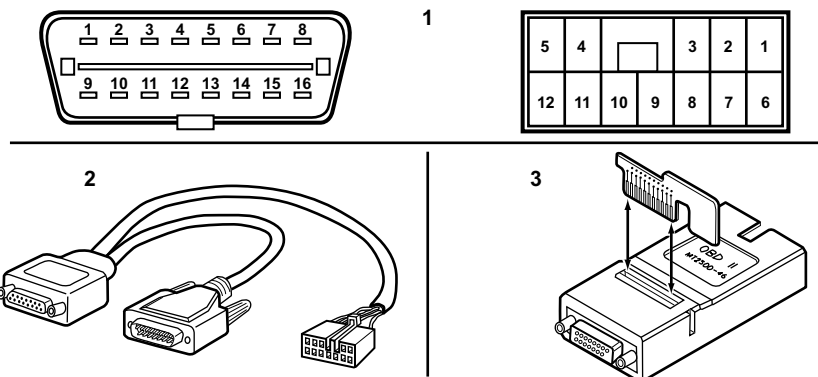

- 1— Connectors
- 2— MITSU-1 adapter
- 3— OBD-II adapter

Figure 5-5 Connectors and adapters for most OBD-II vehicles



NOTE:

Most OBD-II vehicles have 16-pin and 12-pin connectors and use the MITSU-1 adapter connected through the OBD-II connector. The MITSU-1 lead with the 12-pin connector is not connected on all vehicles. Follow on-screen instructions for the correct hookup.

IMPORTANT:

Do not use the battery pack when connecting to Chrysler Import vehicles. Use the Lighter Power Cable or Battery Power Cable.

5.1.2 ABS Manual Code Reading

Chrysler Import antilock brake systems (ABS) transmit Type 11 codes. Figure 5-6 shows how codes display. Table 5-2 explains how to read the codes.

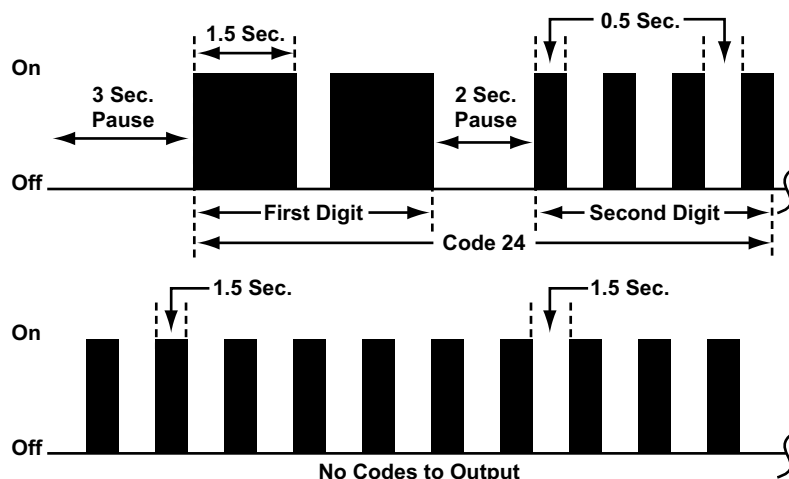

Figure 5-6 Chrysler Imports antilock brake Code Type 11

Table 5-2 Chrysler Import ABS codes type 11

Pattern:	For code output: long and short
Read codes on:	ABS warning lamp
Start codes by:	16-pin OBD-II DLC: jumper terminal 1 to ground; or analog meter across terminals 4 or 5 to terminal 8. 12-pin connector: analog meter across terminals 4 and 12.
When done:	Turn the ignition off, then clear codes.
Code display cycle repeats as long as system is in the diagnostic state. A battery surge that causes the ABS system to fail may cause Code 16 to set.	

5.1.3 Clearing Codes

Trouble codes can be cleared from PCM memory with the scan tool on most 1988 and later models. Select Clear ECM Codes from the main menu.

If code clearing fails for any reason, the previous codes reappear at the top of the data list. If this happens, repeat code clearing.

5.1.4 Codes and Data (Slow)

Some 1988 and later models with the 3.0L SOHC V6 engine transmit data at a 63 baud rate. The Main Menu for these vehicles displays Codes and Data (Slow).

5.1.5 Actuator Tests

The Actuator Tests selection is available from the Main Menu for most pre-OBD-II models. All actuator tests are key-on, engine-off tests, except for the injector and timing tests, which are explained in "Injector Tests (Engine Running Only)".

Selecting Actuator Tests for these vehicles displays a list of available tests. The available tests vary by year and model.

During testing, you must monitor the selected actuator with a voltmeter, ammeter, or by listening for actuator activation. A completed test does not mean that the actuator is operating. The scan tool only monitors the engine control module (ECM) commands to the actuator.

Select an actuator test and the scan tool commands the ECM to activate it. About 5 seconds later, the engine controller deactivates the actuator.

**NOTE:**

All actuator tests except for injector tests must be performed with the key on and engine off (KOEO). If you select a KOEO test with the engine running, a "test rejected" message displays.

Injector Tests (Engine Running Only)

The injector tests available from the actuator test menu are performed with the key on and engine running (KOER) and are available on most pre-OBD-II vehicles.

The number of injector tests available varies by the number of cylinders and type of fuel-injection system (a 4-cylinder MPI system has four tests; a six cylinder system has six).

When you select an injector test, the scan tool commands the ECM to disable the selected injector. About 5 seconds later, the ECM stops the test and the injector is enabled.

5.1.6 EVAP Monitoring Test

The EVAP Monitoring Test is available on most 2001 and later models. This test will force the PCM to run the evaporative system self test. The test can be used to confirm repairs made to the evaporative system without taking the vehicle on an EVAP drive cycle road test. If the system fails, the test DTCs will be set in Codes.

5.1.7 4ITE/F4ACI Quick Learn

Selecting Quick Learn initiates a quick learn test and is usually performed when battery power to the PCM is interrupted. During normal operation, the transmission control module (TCM) continually monitors and “learns”, or updates, clutch volume index (CVI) values.

Newer clutches require less volume, or lower CVI, while worn clutches require more volume, or a higher CVI. If battery power is interrupted, the TCM reverts to baseline values and must “relearn” each clutch circuit.

The transmission learning that occurs during normal operation is intended to compensate for normal wear. However, simply driving the vehicle to “relearn” CVI values is time-consuming, and typically the transmission shift quality is poor. Quick learn allows the TCM to make coarse adjustments quickly, before the vehicle is driven.

5.1.8 4ITE/F4AC1 EMCC Reset

The EMCC Reset selection resets the electronically-modulated converter clutch (EMCC) logic program. The TCM on late-model vehicles with a 4ITE or F4AC1 transmission uses an EMCC logic. The EMCC logic adapts, or learns, during the break-in period on a new vehicle, or after being reset on a vehicle in service.

During the first 500 miles after an EMCC reset, there is no EMCC. During miles 500 to 1500, the TCM gradually decreases EMCC from a 200 RPM to a 60 RPM slip.

5.1.9 4ITE/F4AC1 Battery Disconnect

Selecting Battery Disconnect momentarily interrupts the power supply (B+) signal to the TCM. This resets all of the TCM learned values, without resetting the clock or radio presets.

5.1.10 4ITE/F4AC1 Pinion Factor

The TCM used with the 4ITE/F4AC1 transmission store a programmable value called pinion factor. The Pinion Factor selection provides a way to adjust speedometer calibration to compensate for a tire size change.



To reprogram the pinion factor:

1. Select Pinion Factor.
A “tire size” screen displays.
2. Press **Y** if the displayed tire size is not correct.
A tire size selection screen displays.
3. Select the correct tire size.
Pinion factor programming takes about ten seconds, then the “tire size” screen displays.

5.1.11 4ITE/F4AC1 Clutch Volume Index (CVI) Display

When available, selecting CVI Display displays wear parameters for the automatic transmission clutches. The numbers next to each parameter represent the volume of fluid required to pressurize each clutch circuit.

The CVI values change as the TCM “learns” or updates clutch fill volumes during normal use and wear. New clutches have the maximum amount of friction material. Therefore, newer clutches require less volume and have a lower CVI value.

The range of “normal wear” for CVI values are:

- LR Clutch = 35 to 83
- 2-4 Clutch = 20 to 70
- UD Clutch = 24 to 70
- OD Clutch = 48 to 150

The OD Clutch value varies per model year. Refer to the Fast-Track Domestic Transmission Troubleshooter or the Chrysler Service Manual for correct OD clutch CVI values.

If battery power is interrupted, the TCM reverts to initial, or baseline, CVI values and the TCM must “relearn” each clutch circuit. Be aware, initial CVI values are not used during troubleshooting. They are startup values only.



To “teach” clutch volumes to the transmission control module:

1. Run the quick learn functional test.



NOTE:

The ATM tests actuate solenoids in the transmission. The parking brake must be set during the tests. The shift lever must be in park to exit an ATM test. If the shift lever is not in park, the scan tool does not exit the test.

2. Road test and run through a complete up and down shift sequence.

Avoid moving the throttle on steady acceleration upshifts. The TCM must also learn high-speed and low-speed kickdown shifts. Refer to Chrysler test procedures for more detailed information.

This chapter contains information for testing Daihatsu vehicles with the Asian Import Vehicle Communication Software (VCS). The following systems may be available for testing:

- 1988–92 Charade, Engine
- 1990–92 Rocky, Engine
- 1989–92 Charade, Transmission
- 1991–92 Rocky, ABS
- Manual Code Reading

6.1 Testing Engine, Transmission, and ABS

Testing Daihatsu engine systems and ABS includes:

- “Code Reading Connectors and Locations” on page 40
- “Manual Code Reading” on page 41
- “Code Reading Connector Locations (Transmission)” on page 42

6.1.1 Code Reading Connectors and Locations

Diagnostic test connector location varies by model. On the 1990–92 Rocky it is on the right fender panel, and on the 1988–92 Charade it is on the upper section of the transmission.



To read engine codes automatically (Auto Code Read):

- Connect the MULTI-1 adapter with black terminal converters to the 6-pin connector as shown in Figure 6-1.

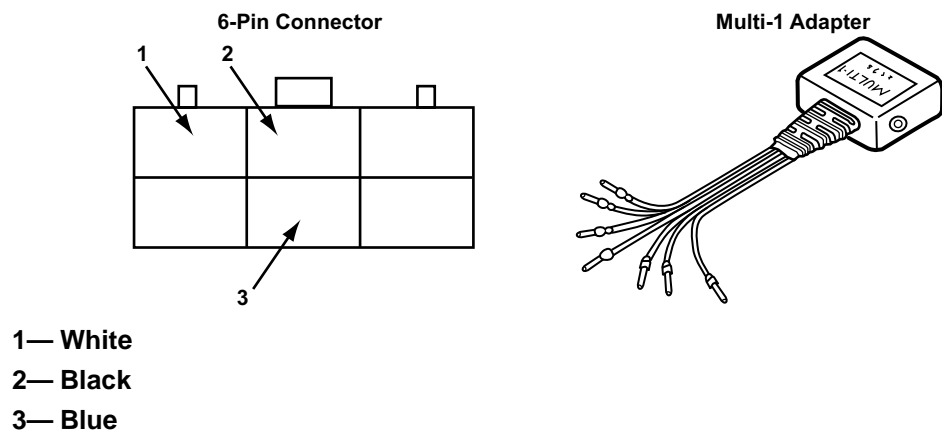

Figure 6-1 Engine connector and MULTI-1 adapter (Auto Code Read)



To read ABS codes from a 1991–92 Rocky automatically (Auto Code Read):

- Connect the MULTI-1 adapter with black terminal converters to the 6-pin connector located near the battery with a gray cover (Figure 6-2).

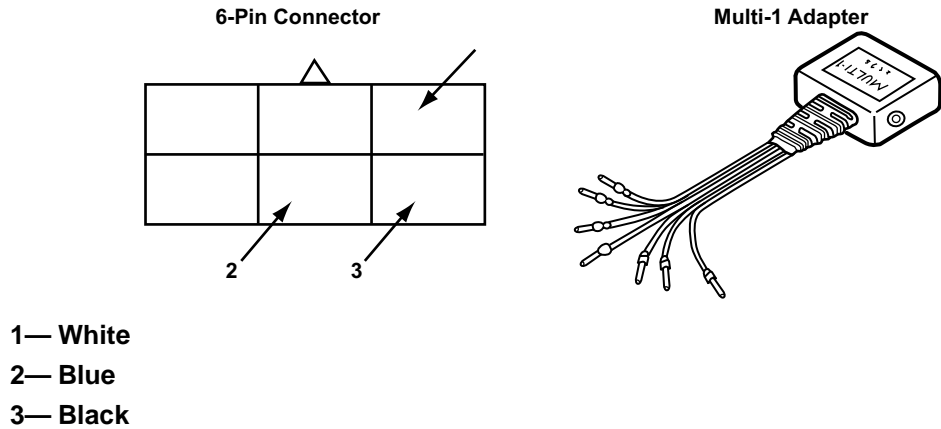

Figure 6-2 Daihatsu Rocky 6-pin diagnostic connector and MULTI-1 adapter

6.1.2 Manual Code Reading

Jump the appropriate connector pins to manually access Daihatsu engine and antilock brake system codes. Refer to Figure 6-4 and Table 6-1 on page 42 to read the codes.



To read engine codes manually (Flash Codes):

- Jump pins shown in Figure 6-3 and turn the ignition on. Engine and ABS codes flash the same. See Figure 6-7 and Table 6-1 for manual code reading information.

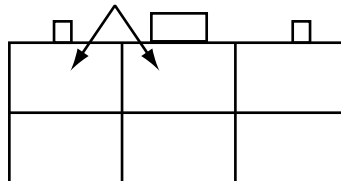

Figure 6-3 Jumper Engine connector. Pins as shown for flash codes (Flash Codes)



To read ABS codes manually (Flash Codes) from a 1991–92 Rocky:

- Jump pins as shown in Figure 6-4 and turn the ignition on. ABS codes and Engine codes flash the same. See Figure 6-7 and Table 6-1 on page 42 for manual code reading information.

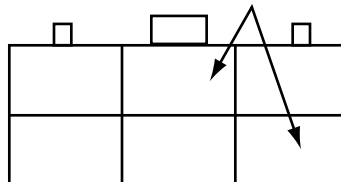

Figure 6-4 Jumper ABS 6-pin connector pins shown for flash codes.

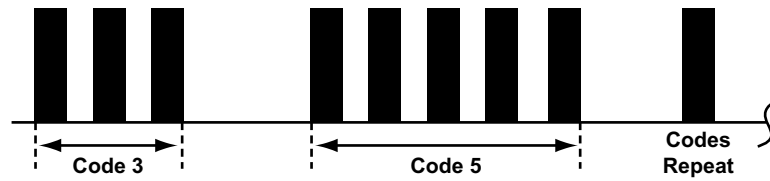

Figure 6-5 Daihatsu engine and antilock brake system code flash pattern

Table 6-1 Daihatsu engine and ABS codes

Pattern:	Straight count
Read codes on:	Depending on the control system, flashes Check Engine lamp, or ABS lamp.
Start codes by:	Jumper two terminals in a connector, then turn the ignition on.
When done:	Turn the ignition off, then clear codes.
Code 1 is a pass code (system OK). After repairing problem, clear codes and drive car; then check for other codes.	

6.2 Testing Transmission Systems

The VCS allows 1989–92 Daihatsu Charade transmission testing.

6.2.1 Code Reading Connector Locations (Transmission)



To read codes automatically from a 1989 charade transmission (Auto Code Read):

- Connect the MULTI-1 adapter with black terminal converters to the 4-pin connector as shown in Figure 6-6. The connector is located near the brake booster and left strut tower.

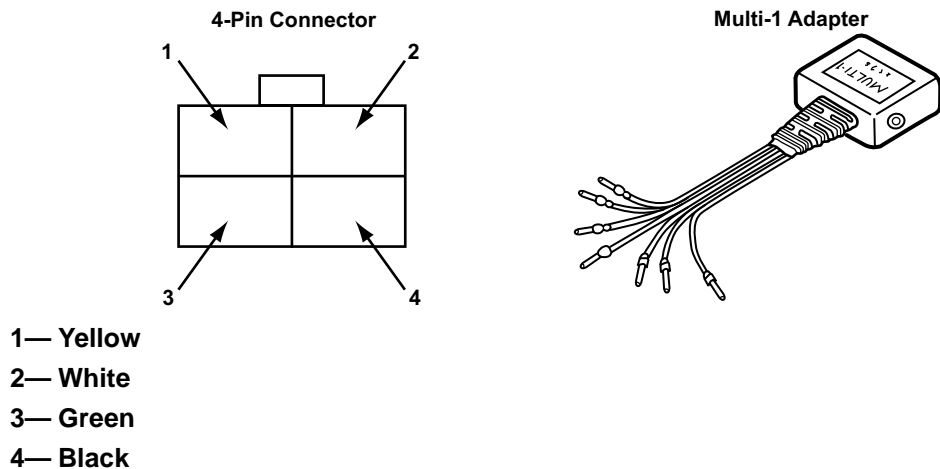
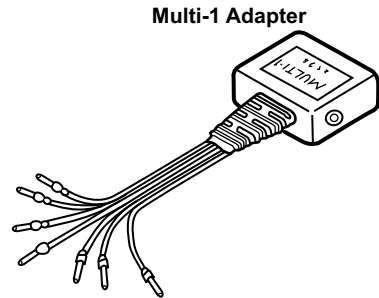
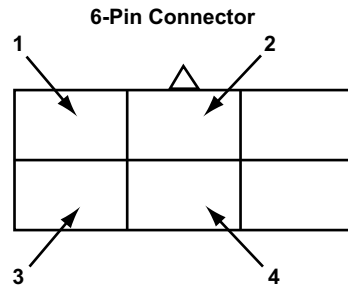

Figure 6-6 1989 transmission 4-pin connector and MULTI-1 adapter



To read codes automatically from 1990–92 Daihatsu Charade transmissions (Auto Code Read):

- Connect the MULTI-1 adapter with black terminal converters to 6-pin connector as shown in Figure 6-7. The connector is located near the bulkhead in the engine compartment.



- 1— Yellow
- 2— White
- 3— Green
- 4— Black with ground extension

Figure 6-7 1990-1992 6-pin Transmission connector and MULTI-1 adapter

This chapter contains information for testing Geo vehicles with the Asian Import Vehicle Communication Software (VCS). The following Geo systems may be available for testing:

- Engine
- Transmission
- Antilock Brake System (ABS)

7.1 Testing Engine, Transmission, and Antilock Brake Systems



NOTE:

Operations described in this section are not available on all tool platforms.

Geo engine, transmission, and antilock brake system testing includes:

- “Code Reading Connectors and Locations” on page 44
- “Hard Codes and Soft Codes” on page 51
- “Clearing Codes” on page 51
- “Field Service Functional Tests” on page 52
- “Prizm Actuator Tests” on page 52

7.1.1 Code Reading Connectors and Locations

Code reading test connector location, procedure, and adapter use varies by model.

**To read 1989–95 Prizm engine codes:**

- Connect the TOY-1 adapter to the connector in the box marked “diagnosis” on either fenderwell (Figure 7-1).

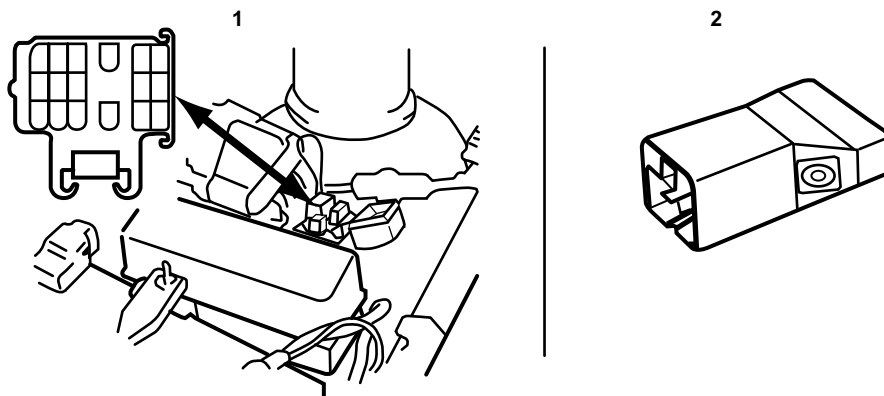

- 1— Connector
- 2— TOY-1 adapter

Figure 7-1 1989-95 Prizm connector location



To read 1989-95 Prizm engine codes (optional):

- Jump diagnosis connector pins as shown in Figure 7-2.

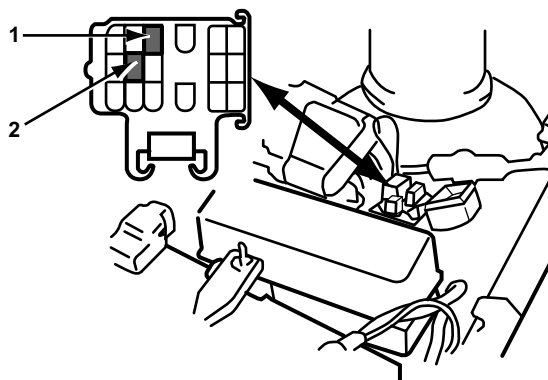

- 1— Terminal E1
- 2— Terminal T, TE, or TE1

Figure 7-2 Jump pins for flash codes



To read 1989-92 Metro (except 1992 1.3L) engine codes:

- Connect the MULTI-1 adapter with red terminal converters to the connector near the left side of the engine (Figure 7-3).

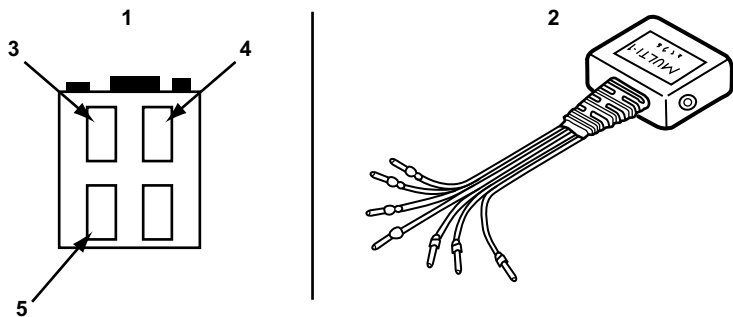

- 1— Connector
- 2— MULTI-1 adapter
- 3— Green
- 4— White
- 5— Black

Figure 7-3 1989–92 (except 1992 1.3L) connector and adapter



To read 1989 Spectrum and 1990–94 Storm engine codes:

- Connect the MULTI-2-D adapter to the connector near the passenger kick panel (Figure 7-4).

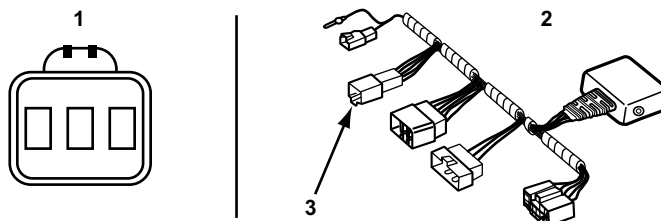

- 1— Connector
- 2— MULTI-2 adapter
- 3— MULTI-2-D

Figure 7-4 1989 Spectrum and 1990–94 Storm connector and adapter



To read 1989 Spectrum and 1990–94 Storm engine codes (optional):

- Jump pins as shown in Figure 7-5.

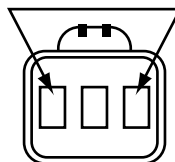

Figure 7-5 Pins to jump for flash codes



To read 1989–95 Tracker engine codes:

- Jump pins as shown in Figure 7-6 on the connector near the left side of the engine.

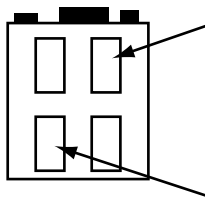

Figure 7-6 1989–95 Tracker connector jump pins



To read 1992–95 Metro (except 1992 1.0L) engine codes:

- Jump pins as shown in Figure 7-7 on the connector near the left strut tower on the firewall.

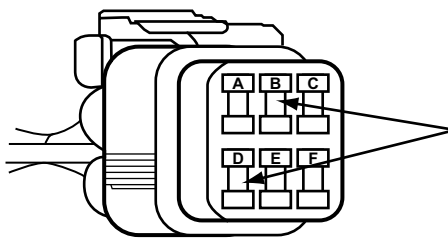
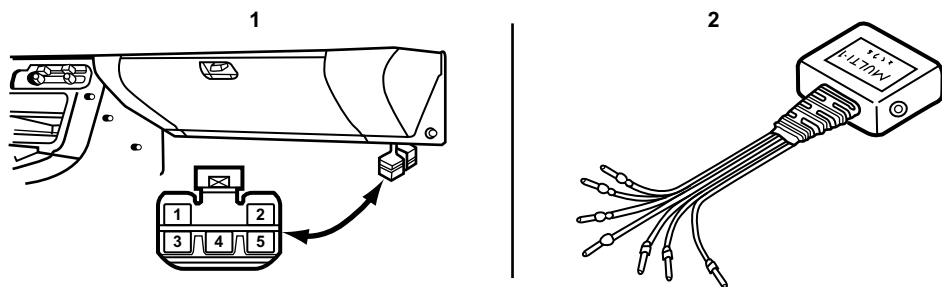

Figure 7-7 1992–1995 Metro connector jump pins



To read 1992–94 Storm 1.8L transmission codes:

- Connect the MULTI-1 adapter to the 5-pin connector under the glove box (Figure 7-8).



- 1— Connector
- 2— MULTI-1 adapter

Figure 7-8 1992–94 Storm 1.8L connector and adapter



To read 1992–94 Storm 1.8L transmission codes (optional):

- Jump pins as shown in Figure 7-9.

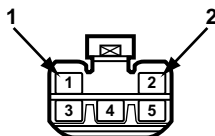

- 1— Red
- 2— Black

Figure 7-9 Pins to jumper for transmission codes



To read 1992–95 1.3L and 1995 1.0L Metro transmission codes:

- Connect the MULTI-1 adapter to the 3-pin connector (Figure 7-10) under the left side of the dashboard.

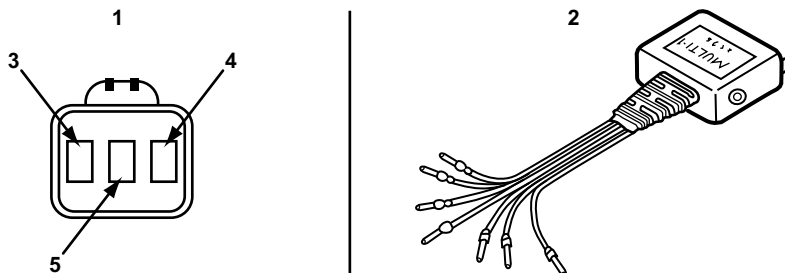

- 1— Connector
- 2— MULTI-1 adapter
- 3— Green
- 4— White
- 5— Black

Figure 7-10 1992–95 1.3L and 1995 1.0L Metro connector and adapter



To read 1992–94 1.0L Metro transmission codes:

- Connect the MULTI-1 adapter as shown in Figure 7-11.

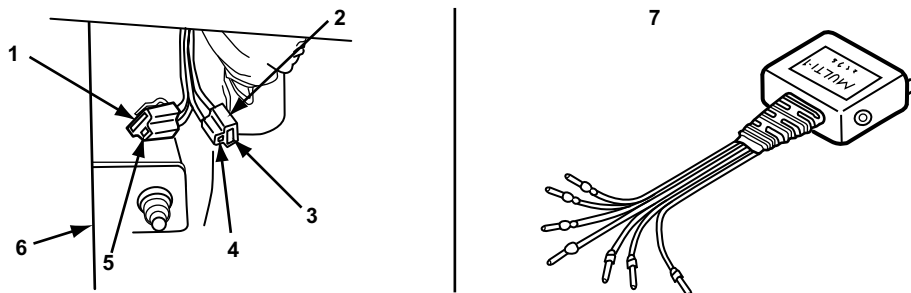

- 1— Diagnostic connector 701—pink wire and black/white wire
- 2— Diagnostic connector 705—black wire and pink/black wire
- 3— Black
- 4— White
- 5— Green
- 6— Steering column
- 7— MULTI-1 adapter

Figure 7-11 1992–94 1.0L Metro transmission connector and adapter

- ▶ To read 1992 Prizm with 4AGE and 1993–95 Prizm with 7AFE transmission codes:
- Connect the TOY-1 adapter to the connector shown in Figure 7-12.

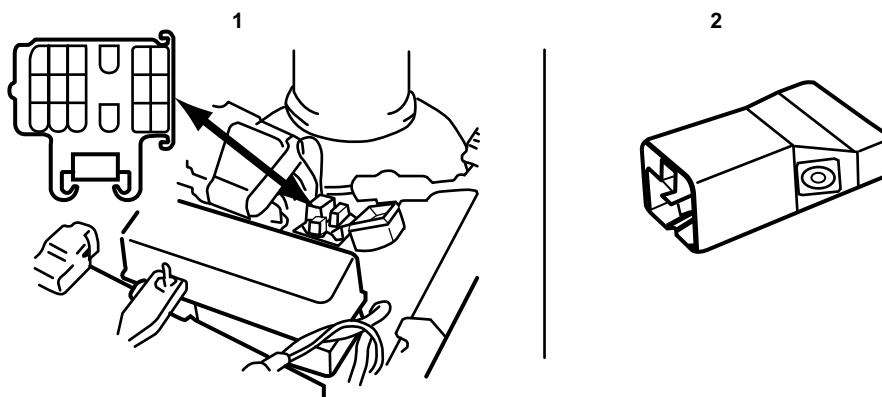

- 1— Connector
2— TOY-1 adapter

Figure 7-12 1992 Prizm with 4AGE and 1993–95 Prizm with 7AFE transmission

- ▶ To read 1990–95 Tracker Kelsey-Hayes RWAL ABS codes:
1. Locate the connector under the dash, left of the steering column near the fuse box.
 2. Turn the key on with the engine off.
 3. Release the parking brake and jump pins 3 and 5 (Figure 7-13) for two seconds, then remove the wire to flash codes.

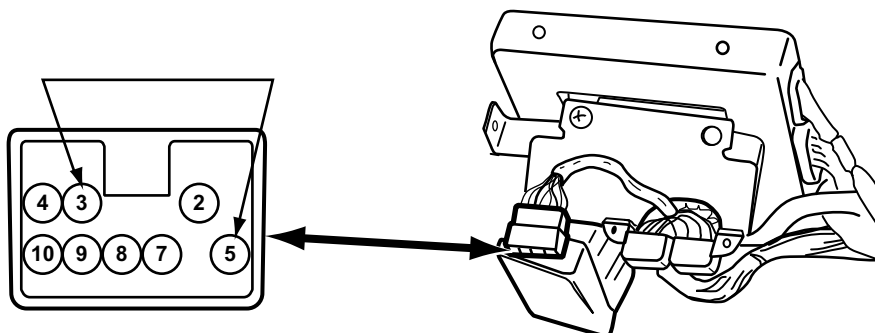

Figure 7-13 1990–95 Tracker RWAL ABS connector jump pins

Manual Code Reading

Several different types of manual code display are used for Geo models:

- Type 01 engine codes, see Figure 7-14 and Table 7-1
- Type 09 engine codes, see Figure 7-15 and Table 7-2
- Type 01 transmission codes, see Figure 7-16 and Table 7-3
- Type 09 transmission codes, see Figure 7-17 and Table 7-4
- ABS codes, see Figure 7-18

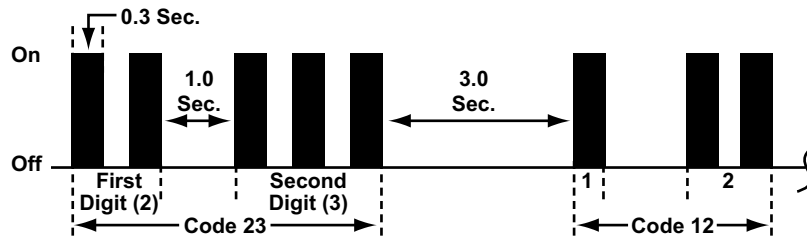

Figure 7-14 Engine Code Type 01

Table 7-1 Engine Code Type 01

Pattern:	10s and 1s
Read codes on:	Check Engine lamp
Start codes by:	Install a jumper wire between two pins and turn the ignition on.
When done:	Turn the ignition off, remove jumper wire, then clear codes.
Code 12 always appears first. Each code repeats three times, including code 12. The code display cycle repeats as long as system is in a diagnostic state.	

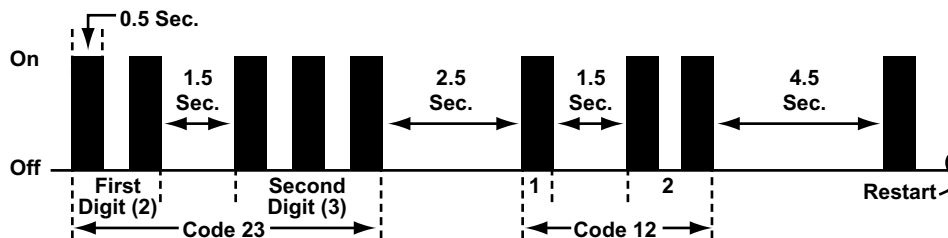

Figure 7-15 Engine Code Type 09

Table 7-2 Engine Code Type 09

Pattern:	10s and 1s
Read codes on:	Check Engine lamp
Start codes by:	Use TOY-1 adapter, turn the ignition on, and select Manual Codes.
When done:	Turn the ignition off, disconnect the scan tool, the clear codes.

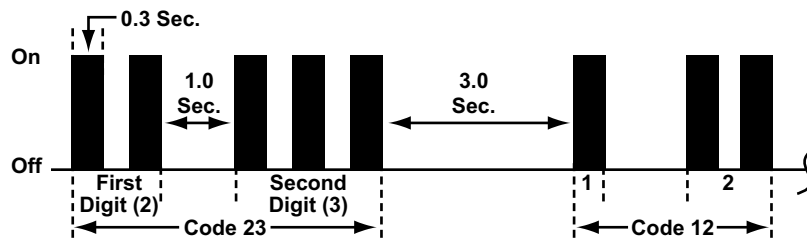

Figure 7-16 Transmission Code Type 01

Table 7-3 Transmission Code Type 01 (part 1 of 2)

Pattern:	10s and 1s
Read codes on:	ECONO lamp

Table 7-3 Transmission Code Type 01 (part 2 of 2)

Start codes by:	Connect the MULTI-1 adapter, turn the ignition on, and select Manual Codes, or install a jumper wire between two pins and turn the ignition on.
When done:	Turn the ignition off, remove the jumper wire, then clear codes.
Code 12 always appears first. Each code repeats three times, including code 12. The code display cycle repeats as long as system is in a diagnostic state.	

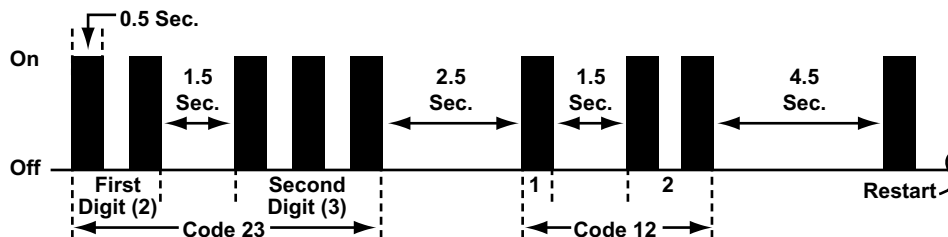

Figure 7-17 Transmission Code Type 09

Table 7-4 Transmission Code Type 09

Pattern:	10s and 1s
Read codes on:	O/D OFF lamp
Start codes by:	Connect the TOY-1 adapter, turn the O/D switch on, turn the ignition on, then select Manual Codes.
When done:	Turn the ignition off, disconnect the scan tool, then clear codes.

Geo ABS codes flash in a straight count with one long flash at the end (Figure 7-18). The code repeats, only one code is stored.

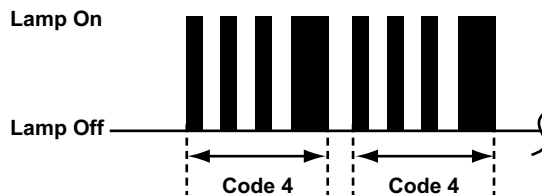

Figure 7-18 ABS diagnostic code pulse

7.1.2 Hard Codes and Soft Codes

Some models separate hard codes from soft (“historical”) codes.

7.1.3 Clearing Codes

Some 1987 and later models allow clearing trouble codes.

If the code-clearing operation fails for any reason, the previous codes reappear at the top of the data list when you return to Codes and Data. If this happens, repeat code clearing.

7.1.4 Field Service Functional Tests



NOTE:

Operations described in this section are not available on all tool platforms.

The Field Service functional test is available for most 1980½ and later Geo models with General Motors control systems.

IMPORTANT:

Do not enter Field Service mode while driving a vehicle. ECM changes to ignition timing, fuel delivery, and other engine functions may affect engine operation and vehicle control.

During Field Service, the VCS grounds diagnostic pin B in the ALDL connector. The ECM does not transmit data in this mode and new trouble codes cannot set. You can use Field Service to check or adjust ignition timing or the idle minimum air rate on some models.

With the key on and the engine off, the instrument panel Check Engine lamp flashes stored trouble codes if any are present or code 12 if no codes are present. With the key on and the engine off, the ECM also energizes all solenoids. You can use Field Service mode to test solenoid operation.

Field Service mode works differently depending on the engine:

- With a carbureted engine running, the Check Engine lamp stops flashing code 12 and new trouble codes cannot be set. The ECM also sets ignition timing to a fixed degree of advance, which lets you check and adjust timing. You also can use the Field Service mode for a system performance check on carbureted engines. Refer to a vehicle service manual for details.
- For some fuel-injected engines, the instrument panel Check Engine lamp flashes rapidly when the engine is running in open loop and slowly when in closed loop. Additionally, in closed loop, the length of the lamp flash indicates whether the exhaust is rich or lean. The lamp flash is longer if the exhaust is rich.

7.1.5 Prizm Actuator Tests

The 1996 and later Geo Prizm offers interactive bidirectional actuator tests. Most of the actuator tests are best performed with the key on and the engine running. The Fuel Pump and Fuel Pump Relay tests must be performed with the key and engine off.

Most tests automatically display data parameters to help determine actuator or system performance, but some tests do not display parameters and require you to monitor the selected actuator. Measure the signal using a digital multimeter, or listen for activation. For most tests, scrolling up and down switches the actuator on and off. Test completion does not mean that the actuator was activated.

IMPORTANT:

Do not enter any actuator test while driving a vehicle on a road test, unless the specific test requires you to do so. PCM changes to ignition timing, fuel delivery, and other engine functions may affect engine operation and vehicle control.

For engine testing, a typical list of actuator tests includes:

- Injector volume

- Idle air control duty cycle
- EGR system
- Fuel pump relay
- Fuel pump
- A/C clutch relay

For transmission testing, a typical list of actuator tests includes:

- O/D cut switch
- Converter lock up
- Shift



To perform an EGR system test:

1. From the Actuator Tests menu, select **EGR System**.
2. Select to continue when the activation screen displays.
The EGR Test screen displays.
3. Raise the engine RPM to 2500. By scrolling up and down, you control the PCM command to the valve that switches sense vacuum to the EGR valve on and off.
The EGR TEMP and ST TRIM parameters on the screen make it easy to determine if exhaust gas is indeed being recirculated.
 - With EGR SYS__OFF, expect low EGR TEMP.
 - With the EGR SYS__ON, the EGR TEMP should rise and the ST TRIM values should change.
4. After testing the EGR, press N to return to the menu.



To perform a Fuel Pump test:

1. From the Actuator Tests menu, select **Fuel Pump**.
2. Select to continue when the activation screen displays.
The Fuel Pump test screen displays.
The test runs for 30 seconds, then the pump shuts off and a test completed message displays.
3. Exit to return to the menu.

This chapter contains information for testing Honda vehicles with the Asian Import Vehicle Communication Software (VCS). The following Honda systems may be available for testing:

- Engine
- Transmission
- Antilock Brake System (ABS)
- Airbag (SRS)

8.1 Testing Engine and Transmission Systems

Honda engine system testing includes:

- “Code Reading Connectors and Locations” on page 54
- “SCS mode” on page 56
- “Code Type” on page 57
- “Manual Code Reading (1986–91) ECM LED ONLY” on page 59
- “Manual Code Reading” on page 62

8.1.1 Code Reading Connectors and Locations

Refer to Figure 8-1 for common connector locations for Honda vehicles. Connector configurations are shown in Figure 8-2, Figure 8-3 and Figure 8-4 on page 55. Refer to Table 8-1 on page 55 to determine which adapter to use to test a specific vehicle.

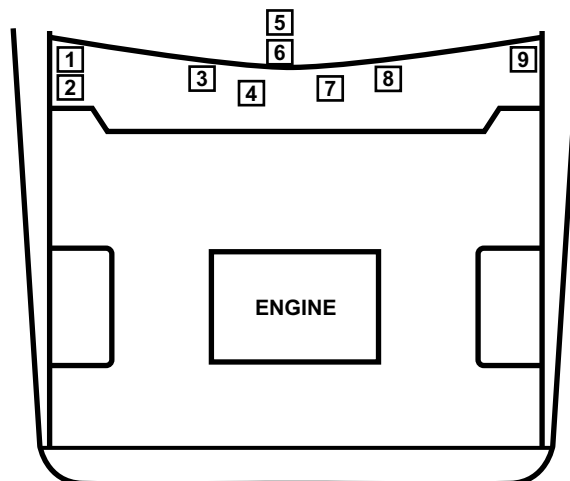

Figure 8-1 Common connector locations

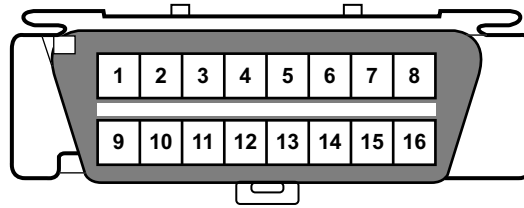

Figure 8-2 OBD-II data link connector (DLC)

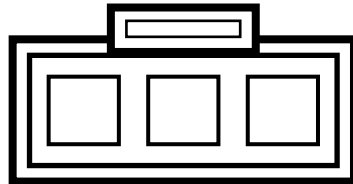

Figure 8-3 3-pin DLC

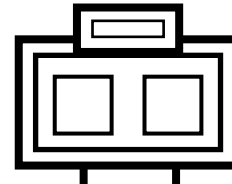

Figure 8-4 2-pin service check signal (SCS) connector

Table 8-1 Common connector locations

VEHICLE	YEAR	SCS 2-PIN	DLC 3-PIN	DLC 16-PIN
Accord, 4-cylinder	1994–95	2	2	
	1996–97	2		6*
	1998–2004			9
Accord, V6	1995–97	2		9
	1998–2004			9
Civic	1992–95	1	1	
	1996–2000	1		9
	2001–04			8
CR-V	1997–2001	4**		4**
	2002–04			7
del Sol	1993–95	1	1	
	1996–97	1		4
Element	2003–04			7
Insight	2000			4
Insight	2001–04			7
Odyssey	1995	3	3	
	1996–98	3		4**
	1999–2004			8
Passport	1994–96	9	9	
	1997–2002			9
Pilot	2003–04			7
Prelude	1992–95	7	7	
	1996	7		5***
	1997–2001	4**		4**
S2000	2000–01			4
	2002–04			7

* Remove ashtray
 ** Remove the DLC cover
 *** Remove the beverage cover

8.1.2 SCS mode

Purpose of SCS (Service Check Signal) mode:

- Enables a diagnostic mode
- Flash out DTCs stored for the PCM, ABS, TCS, and SRS modules
- Code clearing on certain ABS systems
- Bypass two trip detection mode for ODB II drive cycles



NOTE:

Certain OBD-II vehicles use a separate 2 pin SCS connector. Other OBD-II models use a SCS pin in the 16 Pin DLC. Both function the same way. For specific applications, refer to “Code Reading Connectors and Locations”.

Models with a separate 2 pin SCS connector:

Select “How to get codes” from the codes menu, then follow the on-screen instructions.

Models with the SCS in the 16 pin DLC:

The scan tool grounds the appropriate pin of the DLC, which enables the SCS mode. Follow the on-screen instructions.

Two-trip detection bypass

Use SCS mode to bypass ODB ‘two trip detection’ and re-create certain DTCs during diagnosis. Some codes require a back driving sequence (two road tests) where the fault must occur in a similar operating condition.



NOTE:

On ODB II vehicles with the separate 2 pin SCS connector, jumper the 2 pin connector for the SCS mode functions.

A DTC can be captured in one driving event by connecting the Scanner™ and selecting ‘SCS’ mode from the main menu (on applicable vehicles). For scan data usage during SCS mode, you can manually jump the DLC from the backside while the scanner is connected to the DLC.

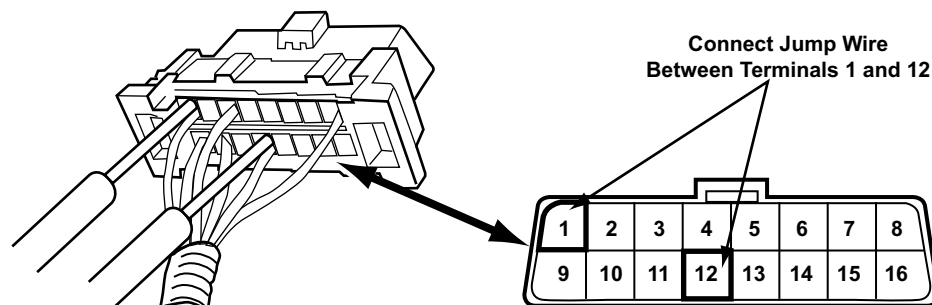

Figure 8-5 Data connector from the wire side (Honda numbering, not the same as SAE)

8.1.3 Code Type

For those systems that rely on manual code reading, you must interpret a DTC from a flashing indicator lamp. The code flash sequence varies by model and system. The scanner therefore refers you to a certain 'code type' (i.e. COPE TYPE 04). Code type is a specific labeling system that identifies the appropriate section in this manual for each subsystem.

ECM Locations - 1985 to 1991 ECM LED

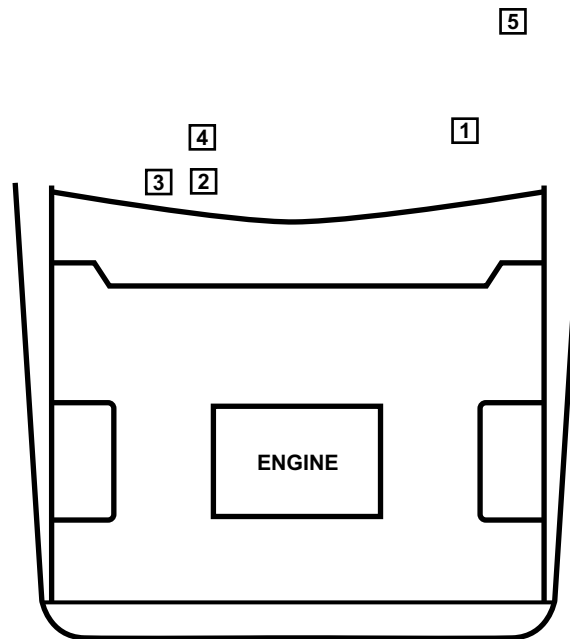
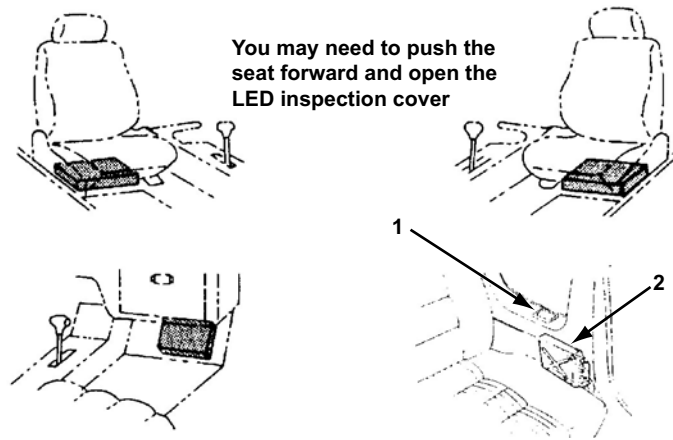

Figure 8-6 Common ECM and LED locations

Table 8-2 Common ECM and LED locations

VEHICLE	YEAR	LOCATION	
Accord LXI	1986–89	1	Under seat
Civic	1985–87	4	Under seat
	1988–91	2	Under carpet
CRX	1985–87	4	Under seat
Prelude	1985–87	5	Under left rear ashtray
	1988–91	2	Under carpet



You may need to push the seat forward and open the LED inspection cover

- 1— Remove ashtray to see LED flash
- 2— ECM

Figure 8-7 Sample ECM locations

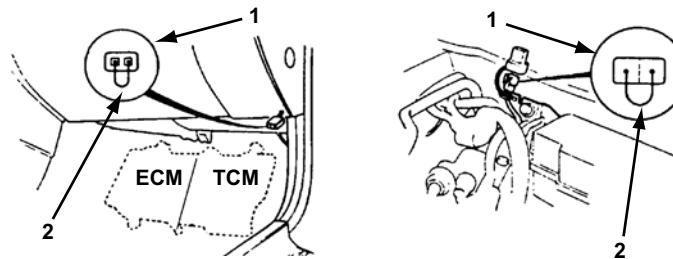

- 1— Service Check connector
- 2— Jump wire

Figure 8-8 1990-later Accord and Prelude Service Check connector locations

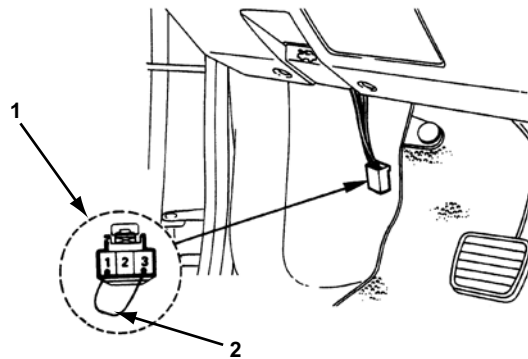

- 1— White DLC
- 2— Jump wire

Figure 8-9 1994-95 Passport data link connector locations

8.1.4 Manual Code Reading (1986–91) ECM LED ONLY

There are 3 types of manual engine codes:

- Type 02, see Figure 8-10 and Table 8-3 on page 59
- Type 03, see Figure 8-11 and Table 8-4 on page 59
- Type 04, see Figure 8-12 and Table 8-5 on page 60

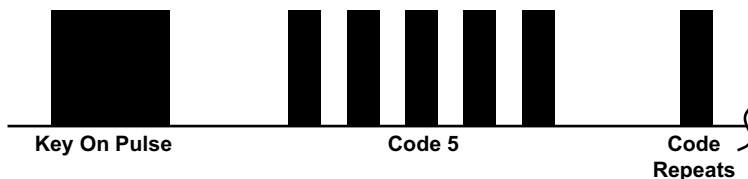

Figure 8-10 Honda engine Code Type 02

Table 8-3 Honda engine Code Type 02

Pattern:	Straight count
Read codes on:	Engine—Red LED on ECM; Trans—Red LED on TCM
Start codes by:	Turn the ignition on.
When done:	Turn the ignition off, then clear codes.
Only one code displayed at a time except on some late model cars. After repairing the problem, clear codes and drive car; then check for other codes.	

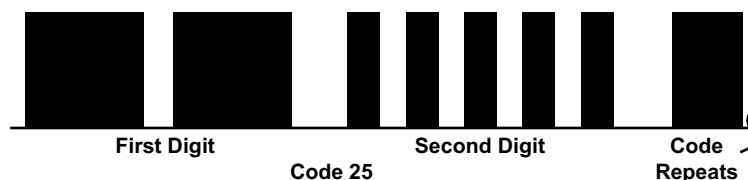

Figure 8-11 Honda engine Code Type 03

Table 8-4 Honda engine Code Type 03

Pattern:	Long and short
Read codes on:	Red LED on ECM; except 1990 and later Accord & Prelude flash codes on CHECK engine lamp on dash
Read codes on:	Red LED on TCM or gear indicator lamp on dash
Start codes by:	Turn the ignition on; except for 1990 and later Accord & Prelude, jumper the check connector, then ignition on.
When done:	Turn the ignition off, then clear codes.
One code displays at a time. Repair, clear codes and drive to check for codes.	

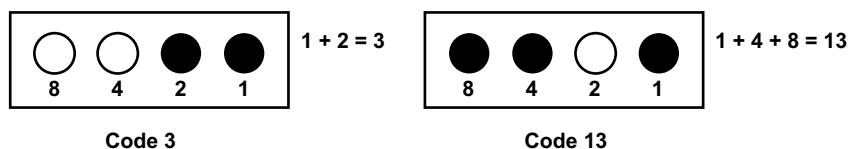

Figure 8-12 Honda engine Code Type 04

Table 8-5 Honda engine Code Type 04

Pattern:	Binary: LEDs assigned numbers 8, 4, 2, 1; add numbers for codes
Read codes on:	Four LEDs on ECM
Start codes by:	Turn the ignition on.
When done:	Turn the ignition off, then clear codes.
Only one code displayed at a time except on some late model cars. After repairing the problem, clear codes and drive car; then check for other codes.	

8.2 Testing ABS

Testing Honda ABS includes:

- “ABS Codes and Data Testing” on page 60
- “Manual Code Reading” on page 62
- “Code Clearing for 1996–2002 Passport with Rear Wheel ABS” on page 65
- “Code Clearing for 1996–2002 Passport with 4-Wheel ABS” on page 65

8.2.1 ABS Codes and Data Testing

The following selections are available for ABS testing:

- “ABS Main Menu” on page 60
- “Codes and Data Menu” on page 61
- “Data (No Codes)” on page 61
- “Codes Only” on page 61
- “Clear Codes” on page 61

ABS Main Menu

After selecting ABS from the System Selection menu, the Main Menu (ABS) displays. Selections vary by model and year.

The following main menu selections are discussed:

- “Codes and Data Menu”
- Movies, Custom Setup, and Troubleshooter are discussed in detail in the user’s manual for your diagnostic tool.

Codes and Data Menu

The following selections are available:

- **Data (No Codes)**—begins communication with the ABS module and displays data parameters.
- **Codes Only**—gathers and displays ABS trouble codes.
- **Clear Codes**—clears ABS memory codes from the ABS ECM memory.
- **Review Codes**—allows you to view codes. (This menu item appears only after code gathering.)
- **Print Codes**—allows you to print codes. (This menu item appears only after code gathering.)

Data (No Codes)

This section has information on viewing ABS data using the scan tool.



To enter and exit ABS data:

1. Enter in the vehicle ID.
2. Turn the ignition on.
3. Select **Data (No Codes)**
4. Turn the ignition off after completing the ABS data tests.

Codes Only

This section has information on retrieving ABS codes using the scan tool.



To gather codes:

1. Select **Codes Only**.
A “key on” verification screen displays. Make sure the ignition is switched on.
2. Select to continue.
The “initializing Communication” message appears.



NOTE:

The “initializing Communication” screen means the scan tool is attempting to start the test, however it does not mean the vehicle has responded. If the message stays on the screen more than a few minutes, the test did not start.

If no codes are detected during the test a “P0000 no faults present” message displays

3. The Code List, which shows all codes in memory displays if codes are present.

Clear Codes

This section has information on clearing ABS codes using the scan tool.



To clear codes:

1. Select **Clear Codes**.
A “key on” verification screen displays. Make sure the ignition is switched on.
2. Select to continue.
A code clearing confirmation screen displays.

3. Select to clear ABS codes.
The DTCs Cleared screen appears,
4. Select to exit.

8.2.2 Manual Code Reading

There are several types of manual codes for Honda ABS:

- Type 02, see Figure 8-13 and Table 8-6 on page 62
- Type 04, see Figure 8-14 and Table 8-7 on page 63
- Type 04a, see Figure 8-15 and Table 8-8 on page 63
- Type 05a, see Figure 8-16 and Table 8-9 on page 64
- Type 06, see Figure 8-17 and Table 8-10 on page 64

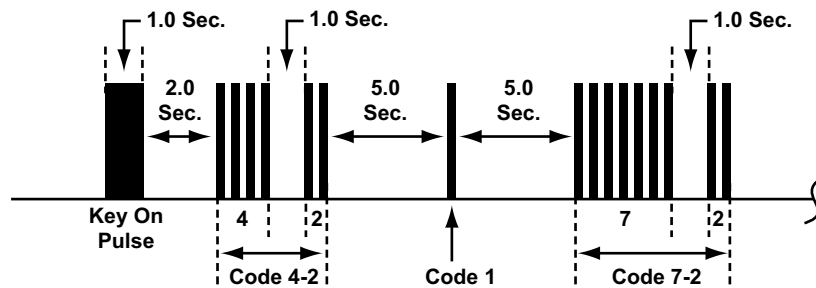

Figure 8-13 Honda ABS Code Type 02

Table 8-6 Honda ABS Code Type 02

Pattern:	Main code and sub-code
Read codes on:	ABS warning lamp
Start codes by:	Short the service check connector and turn the ignition switch on, but do not start the engine. The ABS indicator will stay on for 1 seconds then turn off, main code will flash then pause 1 second, sub-code will flash then turn off for 5 seconds, main code will flash then turn off for 5 seconds, main code will flash and then turn off for one second, sub code will flash
When done:	Disconnect the ABS B2 (15A) fuse in the under-hood fuse-relay box for at least three seconds to erase the ABS control unit's memory. Then turn the ignition key on again and recheck. The memory is erased if the connector is disconnected from the ABS control unit. Before starting the engine, disconnect the jumper wire from the service check connector, or else the Malfunction Indicator Lamp (MIL) will stay on with the engine running.

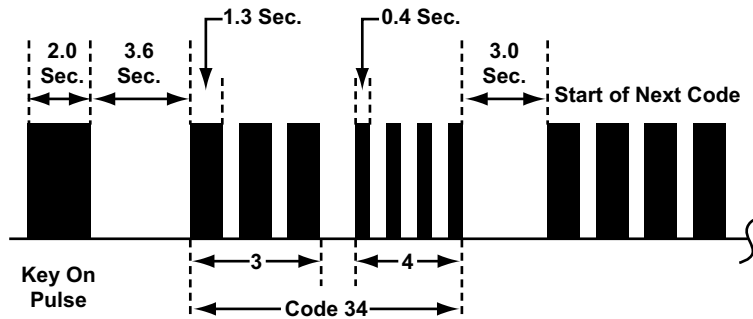

Figure 8-14 Honda ABS Code Type 04

Table 8-7 Honda ABS Code Type 04

Pattern:	10s and 1s
Read codes on:	ABS warning lamp
Start codes by:	Short the service check connector and turn key on, ABS indicator will stay on for 2 seconds then turn off, main code will flash then pause 0.4 seconds, sub-code will flash and pause 3.6 seconds, stored codes will flash only one time per ignition cycle, cycle key at least once to verify codes. Do not press the brake pedal when retrieving codes or the system will go into code clear mode.
When done:	Clear codes with SCS connector shorted. Cycle key to the ON position with brake pedal pressed, ABS light will turn on, then shut off, release pedal, light will turn on, press brake pedal until light turns off, release pedal.

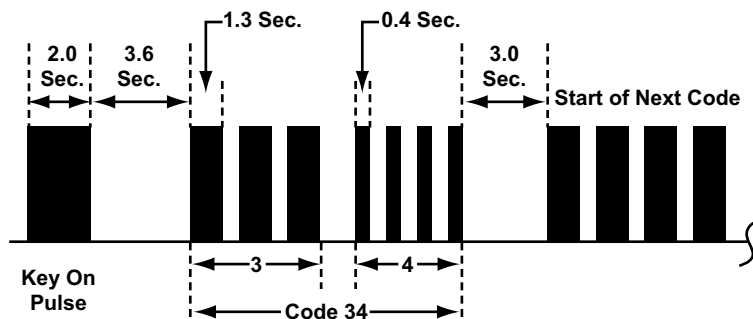

Figure 8-15 Honda ABS Code Type 04a

Table 8-8 Honda ABS Code Type 04a

Pattern:	10s and 1s
Read codes on:	ABS warning lamp
Start codes by:	Short the service check connector and turn key on, ABS indicator will stay on for 2 seconds then turn off, main code will flash then pause 0.4 seconds, sub-code will flash and pause 3.6 seconds, stored codes will flash only one time per ignition cycle, cycle key at least once to verify codes. Do not press the brake pedal when retrieving codes or the system will go into code clear mode.
When done:	Clear codes by cycling the ignition on and off 20 times.

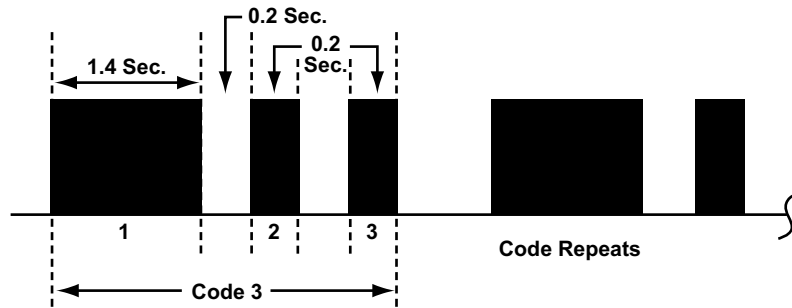

Figure 8-16 Honda ABS Code Type 05a

Table 8-9 Honda ABS Code Type 05a

Pattern:	Straight count (first long flash starts the code, the rest are short flashes)
Read codes on:	Rear ABS indicator lamp or brake lamp
Start codes by:	With the key on, momentarily connect and disconnect terminals 12 and 4 on the OBD-II 16-pin DLC (Figure 8-2). Turn the ignition switch on.
Clearing codes:	Codes are cleared every time the key is cycled off.
When done:	Clear codes, diagnose, repair, test drive, and check for other codes.

If there is no code stored, the Rear ABS lamp goes off and remains off. If a code is stored, the lamp begins flashing. If the Rear ABS lamp stays on continuously, check to see if the DLC leads are shorted together. The leads must only be shorted momentarily.

The ECBM may display a code in mid-count when the diagnostic lead is first grounded. Allow the lamp to flash its sequence several times to be sure you are reading the code accurately. Remember, a long flash starts the code and the rest are short flashes.

The ECBM stores only one code at a time, even if there is more than one problem. Repair the first code, clear memory, then test drive to check for any other codes.

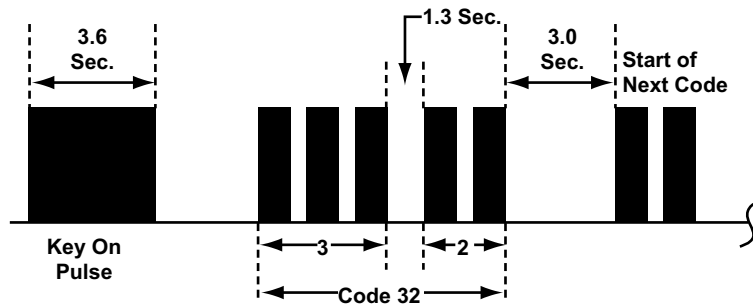

Figure 8-17 Honda ABS Code Type 06

Table 8-10 Honda ABS Code Type 06

Pattern:	Main code and sub-code
Read codes on:	ABS warning lamp
Start codes by:	Short the SCS and turn key on; ABS indicator light will stay on for 2 seconds then turn off; main code will flash then pause 1 second; sub-code will flash and pause 5 seconds; stored codes will flash only one time per ignition cycle; cycle key at least once to verify codes.
When done:	Clear codes by removing the ABS B2 (15A) fuse from the ABS fuse box for 10 seconds.

8.2.3 Code Clearing for 1996–2002 Passport with Rear Wheel ABS

- ▶ To read 1996–2002 Passport with RWAL codes:
- Jump pins 4 and 12 as shown in Figure 8-18.

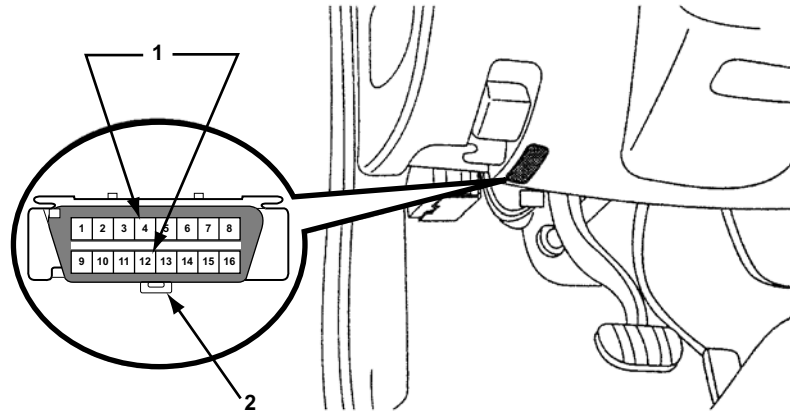

- 1— Data Link Connector (DLC)
2— Pins 4 and 12

Figure 8-18 1996–2002 Passport with RWAL system

8.2.4 Code Clearing for 1996–2002 Passport with 4-Wheel ABS

- ▶ To clear ABS DTCs from a 1996–2002 Passport with 4WAL:
1. With the ignition off, jump pins 4 and 12 of the 16-pin DLC (Figure 8-19).
 2. Switch the ignition on and allow the ABS lamp to flash at least once before proceeding.
 3. Depress the brake pedal by hand until you hear the solenoid click, then release the pedal. Repeat eight times within three seconds.
- After the eighth pedal cycle the ABS lamp stops flashing, lights for one second, then begins flashing code 12 (no codes). Memory is erased once code 12 flashes 4 times.

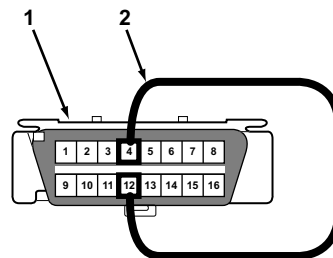

- 1— DLC
2— Jump wire

Figure 8-19 1996–2002 Passport with 4WAL system

8.3 Testing Supplemental Restraint Systems (SRS)

Testing Honda SRS includes:

- “SRS Main Menu” on page 66
- “Manual Code Reading” on page 67
- “Code Clearing” on page 71

8.3.1 SRS Main Menu

After selecting SRS from the System Selection menu, the Main Menu (SRS) displays. Selections vary by model and year.

The following main menu selections are discussed:

- “Codes and Data Menu”
- Movies, Custom Setup, and Troubleshooter are discussed in detail in the user’s manual for your diagnostic tool.

Codes and Data Menu

When Codes and Data Menu is selected, a menu with the following options displays:

- **Data (No Codes)**—begins communication with the SRS module and displays data parameters.
- **Codes Only**—gathers and displays SRS trouble codes.
- **Clear Codes**—clears SRS memory codes from the SRS ECM memory.
- **Review Codes**—allows you to view codes. (This menu item appears only after code gathering.)
- **Print Codes**—allows you to print codes. (This menu item appears only after code gathering.)

Data (No Codes)

This section has information on viewing SRS data using the scan tool.



To enter and exit SRS data:

1. Enter in the vehicle ID.
2. Turn the ignition on.
3. Select **Data (No Codes)**
4. Turn the ignition off after completing the SRS data tests.

Codes Only

This section has information on retrieving SRS codes using the scan tool.

**To gather codes:**

1. Select **Codes Only**.
A “key on” verification screen displays. Make sure the ignition is switched on.
2. Select to continue and the “initializing communication” screen displays.

**NOTE:**

The “initializing communication” screen means the scan tool is attempting to start the test, however it does not mean the vehicle has responded. If the message stays on the screen more than a few minutes, the test did not start.

3. The Code List, which shows all codes in memory displays if codes are present.

Clear Codes

This section has information on clearing SRS codes using the scan tool.

**To clear codes:**

1. Select **Clear Codes**.
A “key on” verification screen displays. Make sure the ignition is switched on.
2. Select to continue and a code clearing confirmation screen displays.
3. Select to clear ABS codes.
The DTCs Cleared screen displays.
4. Select to exit.

8.3.2 Manual Code Reading

There are several types of Honda SRS codes:

- Type 03, see Figure 8-20 and Table 8-11 on page 68
- Type 06, see Figure 8-21 and Table 8-12 on page 68
- Type 06 with a continuous failure, see Figure 8-22 and Table 8-13 on page 69
- Type 06 with an intermittent failure, see Figure 8-23 and Table 8-14 on page 69
- Type 06 with no failure, see Figure 8-24 and Table 8-15 on page 70
- Type 07, see Figure 8-25 and Table 8-16 on page 70

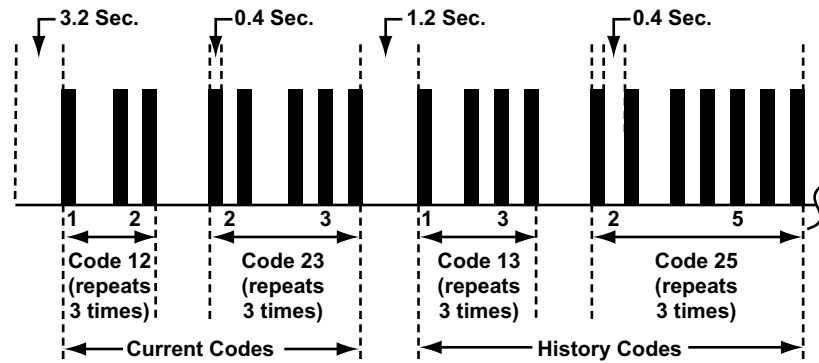

Figure 8-20 Honda SRS Code Type 03

Table 8-11 Honda SRS Code Type 03

Pattern:	10s and 1s
Read codes on:	SRS warning lamp
Start codes by:	With key switch off, connect terminals 13 and 4 on the OBD-II 16-pin DLC (Figure 8-26). Turn ignition switch to the ON position.
Clearing codes:	Clearing codes can only be done using the factory scan tool.
When done:	Turn the ignition off, disconnect the connectors, then clear codes.

The trouble codes are displayed by flashing the warning lamp. Each code displayed consists of a number of flashes that represent the tens digit, a 1.2 second pause, then a number of flashes that represent the ones digit. Each code displays once. Code 12 always flashes first, followed by any current codes. After the current codes, code 13 may flash to indicate the presence of history codes, which then follow. If only history codes are present, code 12 flashes first, then code 13, followed by the historical codes. The code cycle repeats as long as the system is in the diagnostic state.

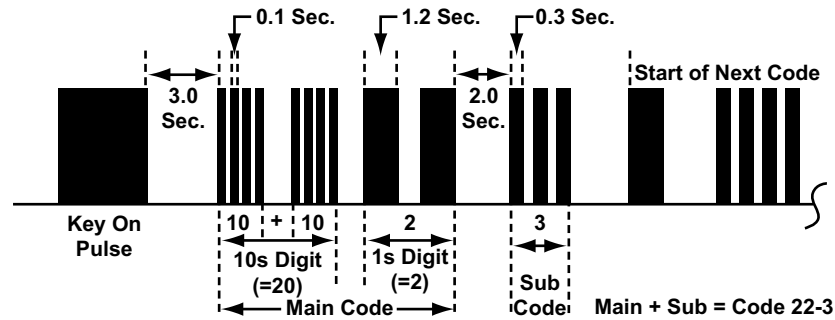

Figure 8-21 Honda SRS Code Type 06

Table 8-12 Honda SRS Code Type 06

Pattern:	Main code and sub-code
Read codes on:	SRS warning lamp
Start codes by:	Short the SCS and turn key on; SRS warning light will turn on then off after 3.0 seconds; if code is greater than 10, four quick flashes (0.1 seconds each) = 10; main code will flash and pause 2.0 seconds and flash again if code is greater than 1; after a 2.0 second pause, sub-code will flash 0.3 second pulses, followed by more flashes if code is greater than 1.
Clearing codes:	See "Code Clearing" on page 71.
When done:	Clear codes.

If the SCS connector is shorted and SRS has no stored DTC, the SRS light remains on continuously.

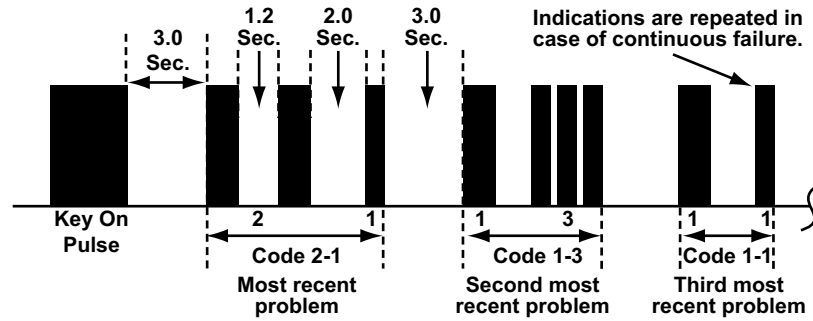

Figure 8-22 Honda SRS Code Type 06 - Continuous Failure, SRS indicator blinks like this

Table 8-13 Honda SRS Code Type 06 - Continuous Failure

Pattern:	Main code and sub-code
Read codes on:	SRS warning lamp
Start codes by:	Short the SCS and turn key on; SRS warning light will turn on then off after 3.0 seconds; Code will then flash for the most recent problem, followed by the second most recent problem, followed by the third most recent problem. Indications are repeated in case of continuous failure.
Clearing codes:	See "Code Clearing" on page 71.
When done:	Clear codes.
2001-04 Civic; 2002-04 CR-V, Insight, and S-2000; 2003-04 Element.	

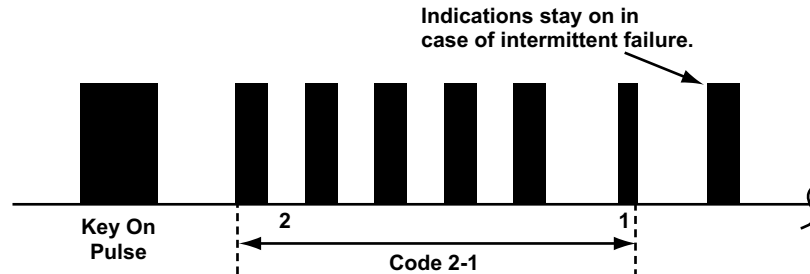

Figure 8-23 Honda ABS Code Type 06 - Intermittent Failure, SRS indicator blinks like this

Table 8-14 Honda SRS Code Type 06 - Intermittent Failure

Pattern:	Main code, sub-code, stays on
Read codes on:	SRS warning lamp
Start codes by:	Short the SCS and turn key on; SRS warning light will turn on then off after 3.0 seconds; Code will then flash, then indicator stays on representing intermittent failure
Clearing codes:	See "Code Clearing" on page 71.
When done:	Clear codes.
2004 Civic, CR-V, Insight, and S-2000	

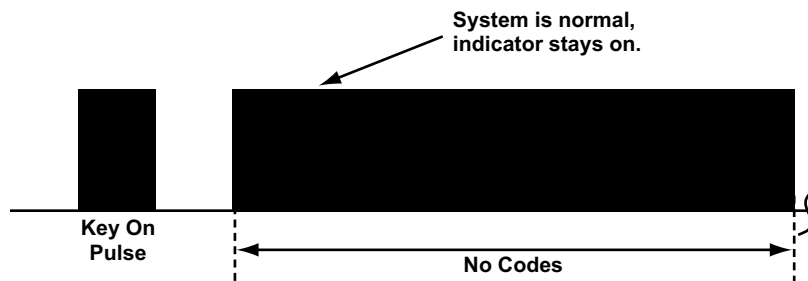

Figure 8-24 Honda SRS Code Type 06 - Normal (no failure), SRS indicator stays on

Table 8-15 Honda SRS Code Type 06 - Normal (no failure)

Pattern:	No code, stays on
Read codes on:	SRS warning lamp
Start codes by:	Short the SCS and turn key on; SRS warning light will turn on then off after 3.0 seconds; The indicator will then stay on indicating that the system is normal.
Clearing codes:	See "Code Clearing" on page 71.
When done:	Clear codes.
2004 Civic, CR-V, Insight, and S-2000	

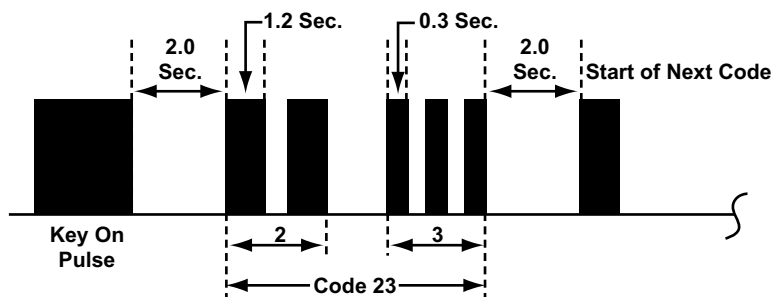
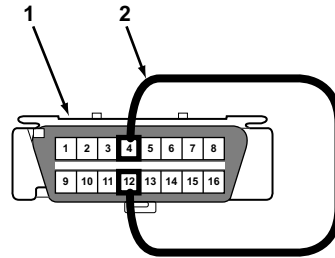

Figure 8-25 Honda SRS Code Type 07

Table 8-16 Honda SRS Code Type 07

Pattern:	Main code and sub-code
Read codes on:	SRS warning lamp
Start codes by:	Short the SCS and turn key on; SRS warning light will turn on then turn off after 2.0 seconds; main code will flash and pause 1.2 seconds and flash again if code is greater than 1; add the flashes together for main code; after a 2.0 second pause, sub-code will flash in 0.3 second pulses, and flash again if code is greater than 1; add the flashes together for sub-code.
Clearing codes:	See "Code Clearing" on page 71.
When done:	Clear codes. If the SCS connector is shorted and SRS has no stored DTC, it's normal to see the SRS light remain on continuously. Some models will flash SRS lamp continuously without pausing.
Computer can store up to three most recent codes.	



- 1— Data link connector (DLC)
- 2— Jumper wire

Figure 8-26 1996–2002 Passport SRS code clearing

8.3.3 Code Clearing



To clear SRS DTCs on all models except Passport:

1. Switch the ignition off.
2. Connect the SCS service connector (Honda 07PAZ-001100) to the yellow 2-pin MES connector. A common jumper wire can also be used, as long as you maintain good contact between the terminals.
3. Switch the ignition on.

The SRS indicator lamp lights for about 6 seconds, then goes off.
4. Remove the SCS service connector from the MES connector within 4 seconds of the lamp switching off.
5. When the SRS indicator lamp lights again, connect the SCS service connector to the MES connector within 4 seconds of the lamp switching on.
6. When the SRS indicator lamp shuts off, remove the SCS service connector from the MES connector within 4 seconds.

The SRS lamp flashes twice to indicate memory has been erased.

7. Switch the ignition off and wait ten seconds.

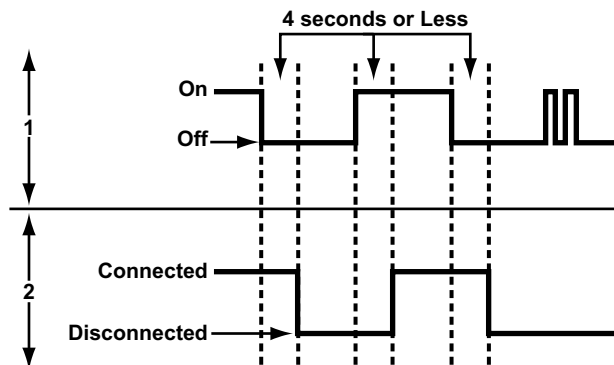

- 1— SRS Indicator Lamp
- 2— MES Connector Terminal

Figure 8-27 SRS code clearing

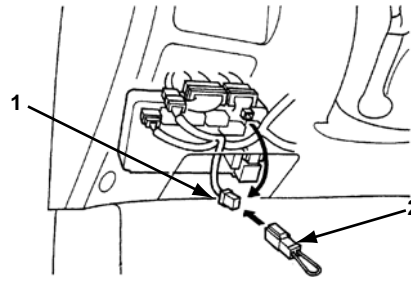

- 1— Memory Erase Signal (MES) connector
- 2— SCS service connector (Honda 07PAZ-0010100)

Figure 8-28 1994–2000 Civic, 1992–1997 del Sol SRS code clearing

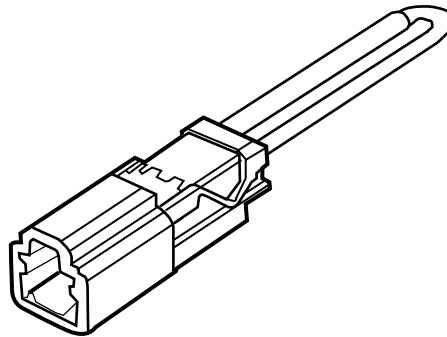
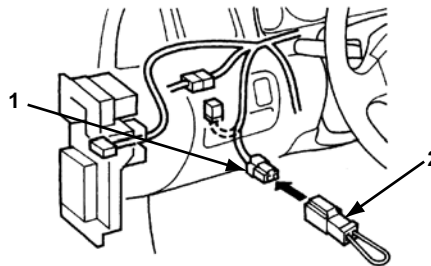
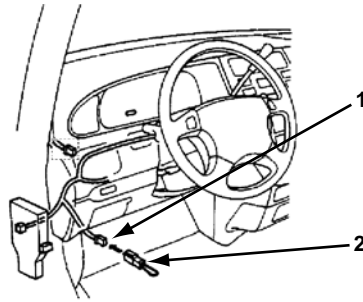

Figure 8-29 SCS Service Connector Honda tool 07PAZ-0010100 (or use jumper wire equivalent)



- 1— MES connector
- 2— SCS service connector (Honda 07PAZ-0010100)

Figure 8-30 1997–2001 Prelude SRS code clearing



- 1— MES connector
- 2— SCS service connector (Honda 07PAZ-0010100)

Figure 8-31 1996–98 Odyssey, 1995–97 Accord SRS code clearing

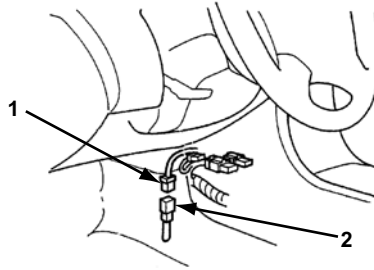

- 1— MES connector
- 2— SCS service connector (Honda 07PAZ-0010100)

Figure 8-32 1994–96 Prelude SRS code clearing

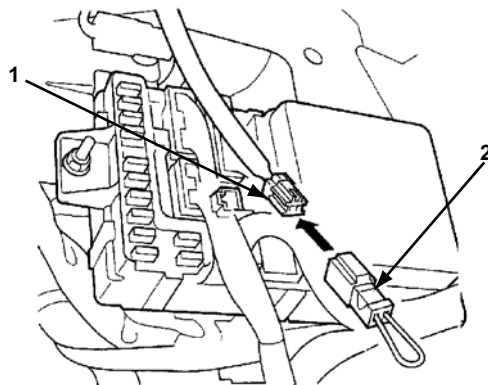

- 1— SCS service connector (Honda 07PAZ-0010100)
- 2— MES connector

Figure 8-33 1999–2002 Odyssey SRS code clearing (left side of dash)

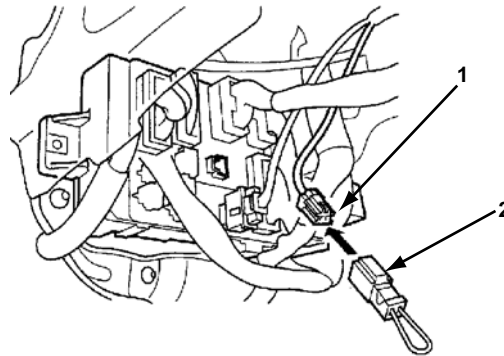

- 1— MES connector
- 2— SCS service connector (Honda 07PAZ-0010100)

Figure 8-34 1998–2003 Accord, 2000–03 S2000 SRS code clearing (left side of dash)

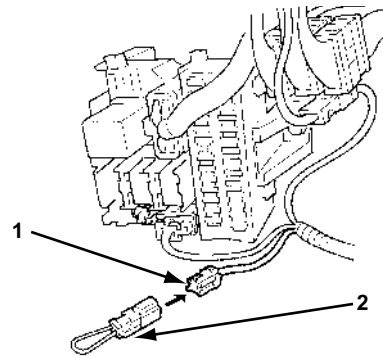

- 1— MES connector
- 2— SCS service connector (Honda 07PAZ-0010100)

Figure 8-35 2004 S2000 SRS code clearing (left side of dash)

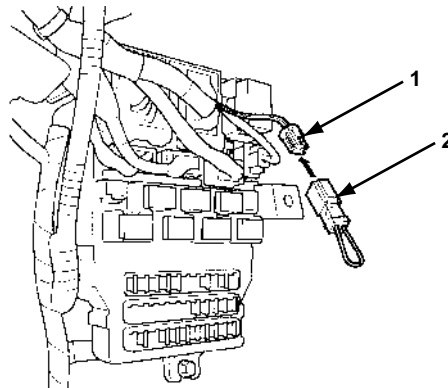

- 1— MES connector
- 2— SCS service connector (Honda 07PAZ-0010100)

Figure 8-36 2004 Accord SRS code clearing (left side of dash)

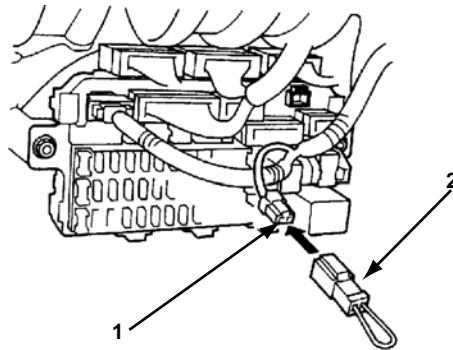

- 1— SCS service connector (Honda 07PAZ-0010100)
- 2— MES connector

Figure 8-37 1997–2001 CR-V SRS code clearing (left side of dash)

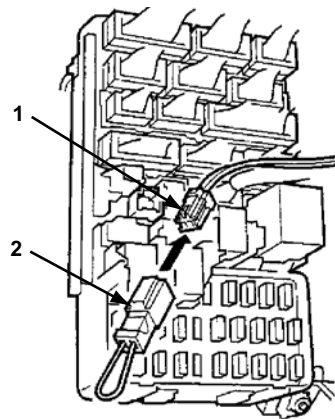

- 1— MES connector
- 2— SCS service connector (Honda 07PAZ-0010100)

Figure 8-38 2002–04 CR-V SRS code clearing (left side of dash)

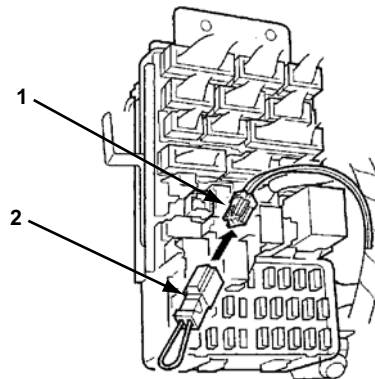

- 1— MES connector
- 2— SCS service connector (Honda 07PAZ-0010100)

Figure 8-39 2001–04 Civic, 2003–04 Element SRS code clearing

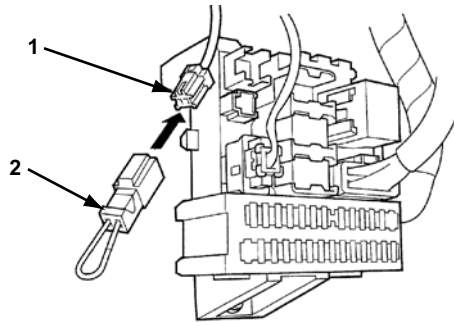

- 1— MES connector
- 2— SCS service connector (Honda 07PAZ-0010100)

Figure 8-40 2000–04 Insight SRS code clearing (left side of dash)

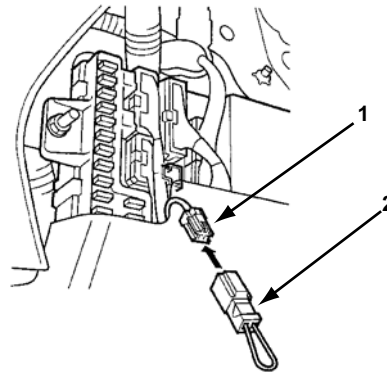

- 1— MES connector
- 2— SCS service connector (Honda 07PAZ-0010100)

Figure 8-41 2003–04 Pilot SRS code clearing

This chapter contains information for testing Hyundai vehicles with the Asian Import Vehicle Communication Software (VCS). The following Hyundai systems may be available for testing:

- Engine
- Transmission
- Antilock Brake System (ABS)
- Airbag (SRS)

9.1 Testing Engine, Transmission, ABS, and SRS

Hyundai engine, transmission, and airbag (SRS) testing includes:

- “Code Reading Connectors and Locations” on page 77
- “Clearing Codes” on page 79
- “Actuator Tests” on page 79

9.1.1 Code Reading Connectors and Locations

Refer to Figure 9-1 below and Table 9-1 on page 78 Hyundai diagnostic connector locations and adapter usage information.

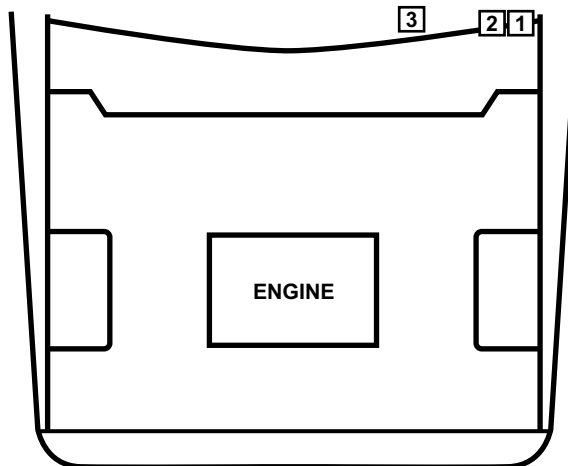

Figure 9-1 Common connector locations

Table 9-1 Common connector locations

VEHICLE	YEAR		LOCATION
Accent	1995–99	2	Above coin holder
	2001–06	3	Near hood release
Azera	2006	3	
Elantra	1992–95	1	In fuse box
	1996–06	3	Under dash near steering column
Excel	1990–94	1	In fuse box
Santa Fe	2001–06	1	Behind fuse panel
Scoupe	1991–95	1	In fuse box
Sonata	1989–95	1	In fuse box
	1996–06	3	Under dash near steering column
Tiburon	1997–01	3	Under dash near steering column
	2003–06	1	Behind fuse panel
Tucson	2005–06	3	
XG300/XG350	2001–05	3	Under dash near steering column



To read codes from 1995 and earlier vehicles:

- Use the HYUN-2 adapter (Figure 9-2).

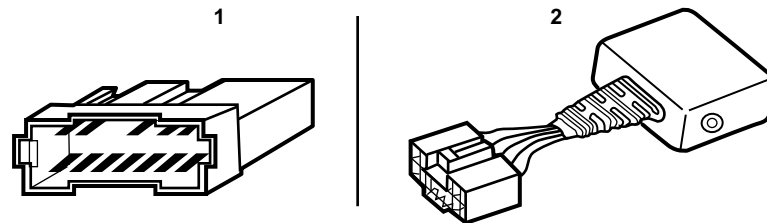

- 1— Connector
- 2— HYUN-2 adapter

Figure 9-2 Connector and adapter for most OBD-I vehicles



To read codes from most 1996 and later vehicles:

- Use the OBD-II adapter with the specified Personality Key™ device (Figure 9-3).

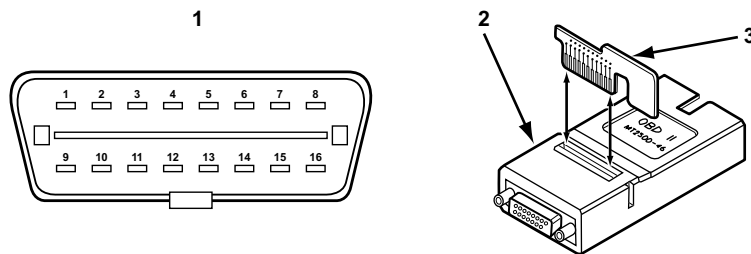

- 1— 16-pin DLC
- 2— Personality Key™ device
- 3— OBD-II adapter

Figure 9-3 OBD-II DLC and adapter

**NOTE:**

Always use the Personality Key™ device specified in the on-screen instructions.

9.1.2 Clearing Codes

Most 1988 and later Hyundai models let you clear codes from PCM memory using the Scanner.

When codes are cleared, the scan tool returns to the previous test mode, and the “No Codes Present” message displays to indicate codes are cleared.

If code clearing fails for any reason, the previous codes display at the top of the data list when you return to Codes and Data. If this happens, repeat code clearing.

9.1.3 Actuator Tests

The Actuator Tests selection is available from the Main Menu for most pre-OBD-II models and most 2001–2006 OBD-II models. All actuator tests are key-on, engine-off tests, except for the injector and timing tests. See also in “Injector Tests (Engine Running Only)”.

Selecting Actuator Tests for these vehicles displays a list of available tests. The available tests vary by year and model.

During testing, monitor the selected actuator with a voltmeter, ammeter, or by listening for actuator activation. A completed test does not mean that the actuator was activated. The scan tool only monitors the engine control module (ECM) commands to the actuator.

When an actuator test is selected, the scan tool commands the ECM to activate it. About 5 seconds later, the ECM deactivates the actuator and a test completed message displays.

**NOTE:**

All actuator tests except for injector tests must be performed with the key on and engine off (KOEO). If you select a KOEO test with the engine running, a warning screen displays.

Injector Tests (Engine Running Only)

The injector tests available from the actuator test menu are performed with the key on and engine running (KOER) and are available on most pre-OBD-II vehicles.

The number of injector tests available varies by the number of cylinders and type of fuel-injection system (a 4-cylinder MPI system has four tests; a six cylinder system has six).

When you select an injector test, the scan tool commands the ECM to disable the selected injector. About 5 seconds later, the ECM stops the test and the injector is returned to operational.

This chapter contains information for testing Isuzu vehicles with the Asian Import Vehicle Communication Software (VCS). The following Isuzu systems may be available for testing:

- Engine
- Transmission
- Antilock Brake System (ABS)
- Supplemental Restraint System (SRS)
- Transfer Case
- Body Control Module (BCM)
- Instrument Panel Cluster (IPC)

10.1 Testing Engine and Transmission Systems

Isuzu engine and transmission system testing includes:

- “Engine And Transmission Code Reading Connectors and Locations” on page 80
- “Manual Code reading (Engine)” on page 86
- “Clearing Codes” on page 87
- “Road Test (No C&D)” on page 87
- “Field Service Functional Tests” on page 88

10.1.1 Engine And Transmission Code Reading Connectors and Locations

Figure 10-1 and Table 10-1 show common engine diagnostic connector locations for Isuzu vehicles. Figure 10-2 and Table 10-2 show common transmission diagnostic connector locations.

The following engine and transmission code reading procedures are included:

- “To read codes from 1986–87 Trooper:” on page 82
- “To read codes from 1984–95 Pickup 1988–95 Amigo, and 1991–95 Rodeo:” on page 84
- “To read codes from vehicles with a 12-pin connector:” on page 85
- “To read codes from 1988–89 Impulse:” on page 85
- “To read codes from 1985½–89 I-Mark and 1990 and later Impulse:” on page 85
- “To read codes from 1988–89 Impulse (optional):” on page 86
- “To read codes from 1985½–89 I-Mark and 1990 and later Impulse (optional):” on page 86

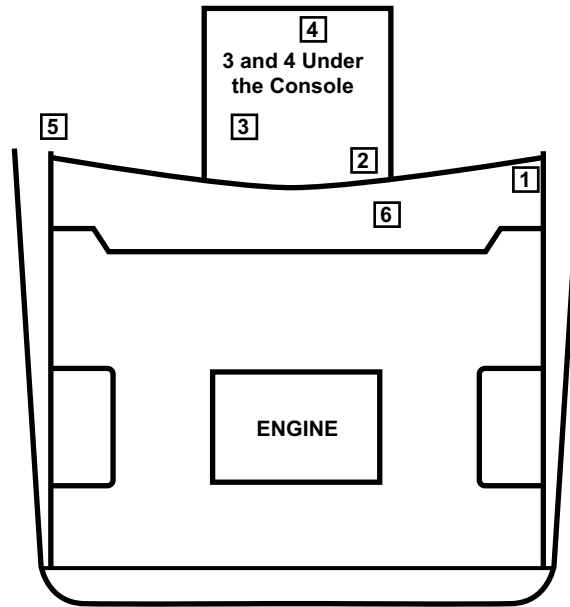

Figure 10-1 Isuzu common engine connector location

Table 10-1 Common engine connector locations

VEHICLE	YEAR	CONNECTOR LOCATION
Amigo	1990–94	1 (ECM)
Ascender	2003–04	1
Axiom	2002–04	1
I-Mark	1984–89	5
Impulse	1984–89	5
	1990–92	1 (ECM)
Pickup	1990–95	1 (ECM)
Rodeo	1990–95	1 (ECM)
	1996–2004	1
Stylus	1990–93	1 (ECM)
Trooper	1990–91	1 (ECM)
	1992–94	6 (ECM)
	1996–2002	1
Trooper 2.3L	1986–87	2
Trooper 2.6L	1988–91	4
Trooper 2.8L	1989–91	3
Vehicross	1999–2001	1

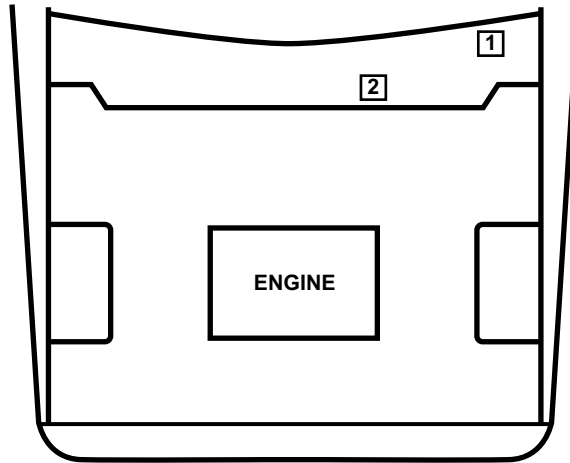

Figure 10-2 Common transmission connector locations

Table 10-2 Common transmission connector locations

VEHICLE	YEAR	CONNECTOR LOCATION
Amigo	1990–94	1
Impulse	1990–92	1
Pickup	1990–95	1
Rodeo	1990–95	1
Stylus	1990–93	1
Trooper	1990–91	1
	1992–94	2



NOTE:

The 1984–85 Trooper connector is hard to find (Figure 10-3).

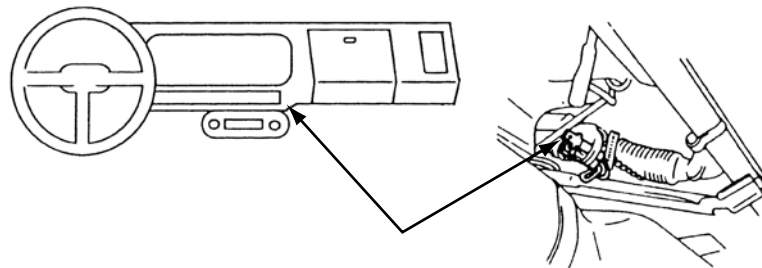
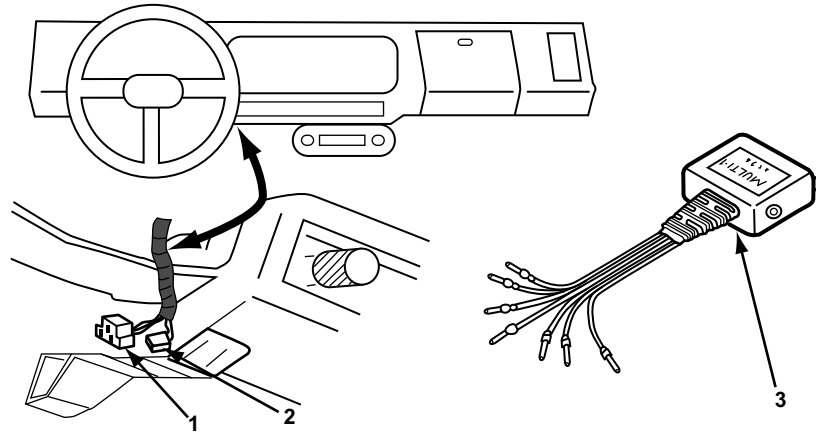

Figure 10-3 1984–1985 Isuzu Trooper diagnostic connector



To read codes from 1986–87 Trooper:

- Connect the MULTI-1 adapter to the ALDL or diagnostic connector (Figure 10-4 on page 83).



- 1— ALDL connector
- 2— Diagnostic connector
- 3— MULTI-1 adapter

Figure 10-4 1986–87 Trooper connectors and adapter

Diagnostic connector locations for the 1988–91 Trooper are shown in Figure 10-5.

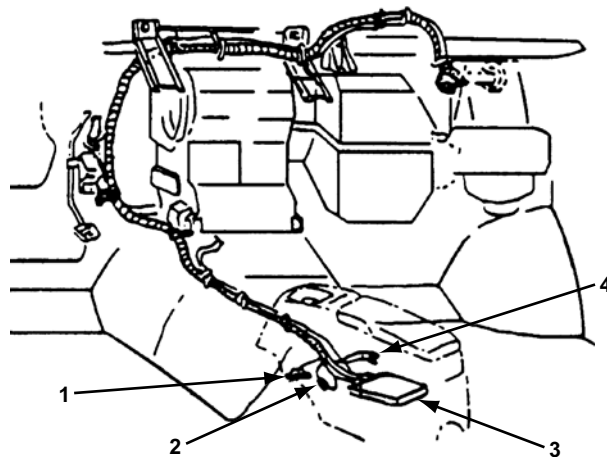

- 1— ALDL connector
- 2— Distributor set timing connector
- 3— ECM
- 4— Diagnostic lead terminal

Figure 10-5 1988–91 Trooper connectors

Diagnostic connector locations for the 1984–95 Pickup, 1988–95 Amigo, and 1991–95 Rodeo are shown in Figure 10-6 on page 84.

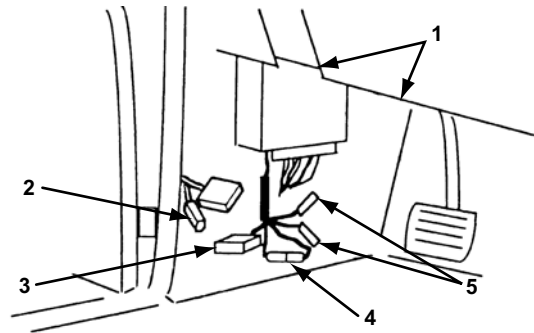

- 1— 1984–87 Impulse (leads and ALDL not shown)
- 2— RWAL 1-pin connector
- 3— ALDL (3-pin connector)
- 4— Timing set connector
- 5— Diagnostic leads (connect together for flash codes)

Figure 10-6 1984–95 Pickup, 1988–95 Amigo, and 1991–95 Rodeo connectors



To read codes from 1984–95 Pickup 1988–95 Amigo, and 1991–95 Rodeo:

- Connect the MULTI-1 adapter with the white terminal converters (Figure 10-7 and Figure 10-8).

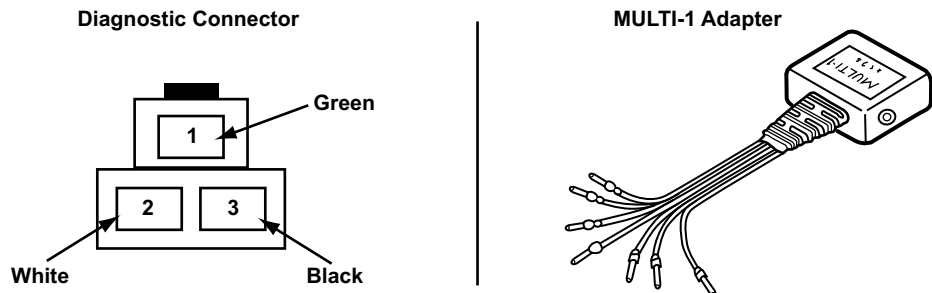
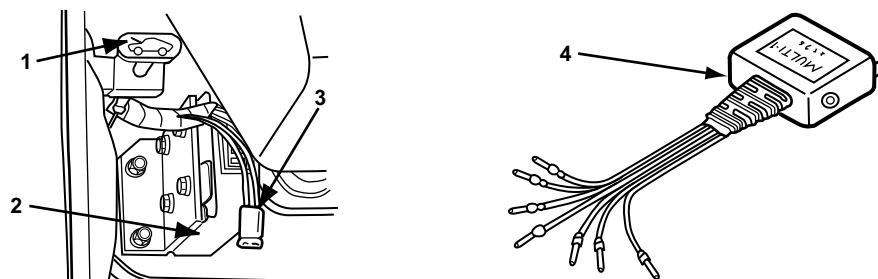

Figure 10-7 1984–95 Pickup 1988–95 Amigo, and 1991–95 Rodeo connector and adapter



- 1— Hood release
- 2— ECM
- 3— Diagnostic connector
- 4— MULTI-1 adapter

Figure 10-8 1988–91 Trooper with automatic transmission connector location



To read codes from vehicles with a 12-pin connector:

- Connect the MULTI-1 adapter to the connector (Figure 10-9) or use the GM-1 adapter.

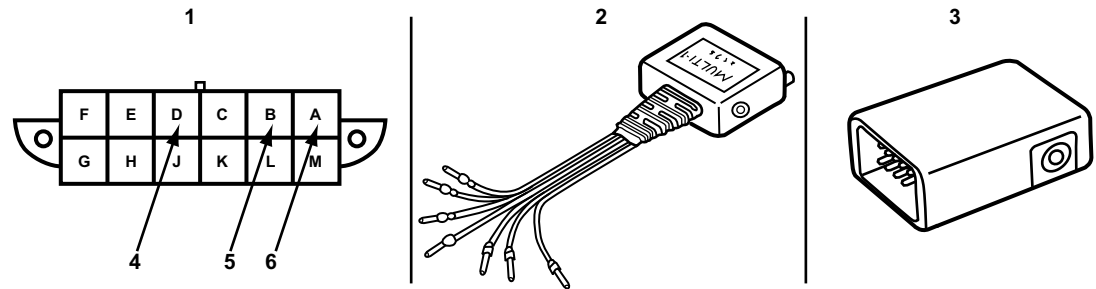

- 1— Diagnostic connector
 2— MULTI-1 adapter
 3— GM-1 adapter
 4— Green MULTI-1 wire
 5— White MULTI-1 wire
 6— Black MULTI-1 wire

Figure 10-9 12-pin connector and adapters



To read codes from 1988–89 Impulse:

- Connect the MULTI-1 adapter with the white terminal converters (Figure 10-10).

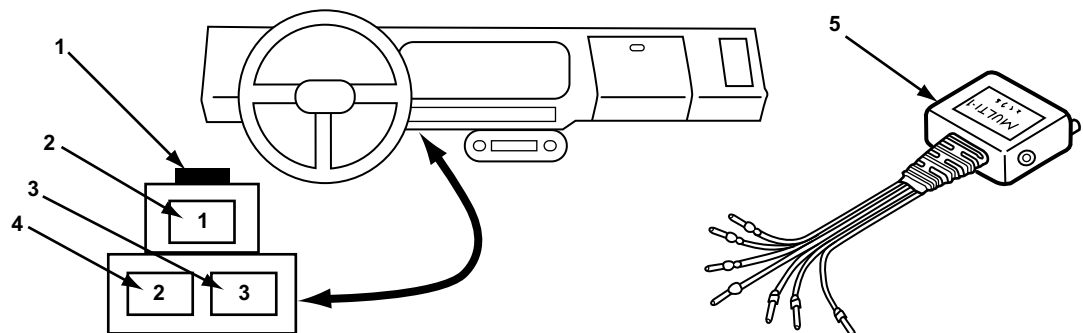

- 1— Diagnostic connector
 2— Black MULTI-1 wire
 3— Green MULTI-1 wire
 4— White MULTI-1 wire
 5— MULTI-1 adapter

Figure 10-10 1988–89 Impulse connector and adapter



To read codes from 1985½–89 I-Mark and 1990 and later Impulse:

- Connect the MULTI-2-D adapter to the white 3-pin connector (Figure 10-11 on page 86).

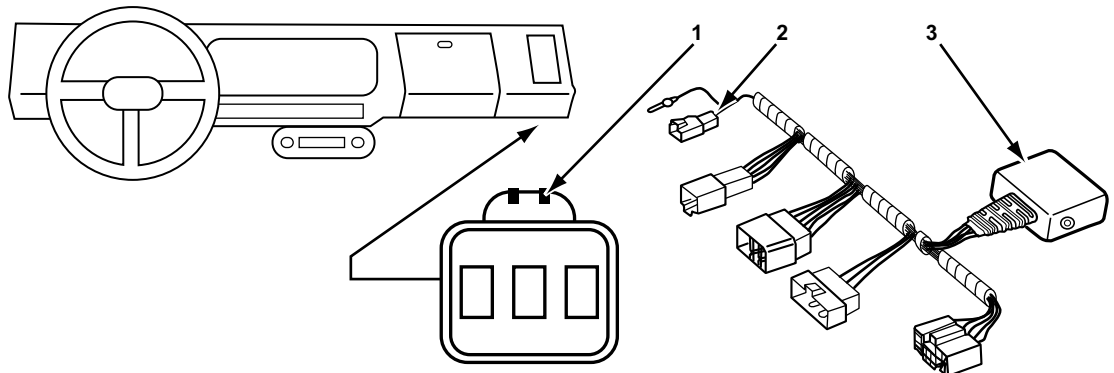

- 1— Diagnostic connector
 2— MULTI-2-D
 3— MULTI-2 adapter

Figure 10-11 1985½–89 I-Mark, 1990 and later Impulse connector and adapter

10.1.2 Manual Code reading (Engine)

Use one of the following procedures to manually read codes on I-mark and Impulse models. Isuzu engine and transmission systems flash Type 05 codes, refer to Figure 10-14 and Table 10-3 on page 87 for Type 05 code information.



To read codes from 1988–89 Impulse (optional):

- Jump pins 2 and 3 as shown in Figure 10-12.

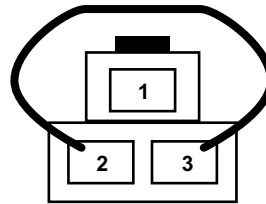

Figure 10-12 1988–89 Impulse jump pins



To read codes from 1985½–89 I-Mark and 1990 and later Impulse (optional):

- Jump pins as shown in Figure 10-13.

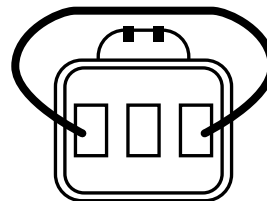

Figure 10-13 1985½–89 I-Mark, 1990 and later Impulse jump wire

Code Type 05

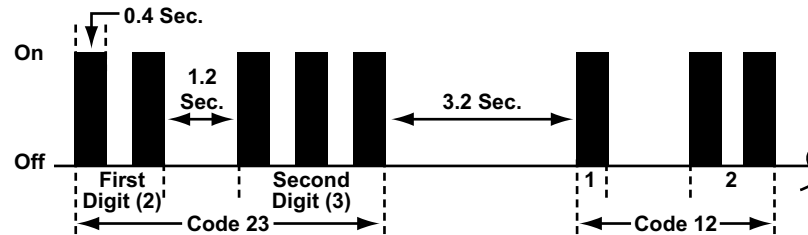

Figure 10-14 Isuzu engine Code Type 05

Table 10-3 Engine Code Type 05

Pattern:	10s and 1s
Read codes on:	Check Engine lamp
Start codes by:	Connect two diagnostic connector terminals or jumper two terminals in a connector and turn the ignition on.
When done:	Turn the ignition off, disconnect the connectors, and clear codes.
Code 12 always appears first. Each code repeats three times, including code 12. Code display cycle repeats as long as system is in diagnostic state.	

10.1.3 Clearing Codes

Some 1987 and later models allow clearing trouble codes using the Scanner.

If the code-clearing operation fails for any reason, the previous codes will reappear at the top of the data list when you return to Codes and Data. If this happens, repeat code clearing.

10.1.4 Road Test (No C&D)

Many Isuzu models offer a Road Test (No C&D) mode. This option removes the scan tool resistive load applied to the vehicle ECM in Codes and Data, so you can safely drive the vehicle with the scan tool connected.



NOTE:

No codes or data are transmitted when operating in this mode.

Some Isuzu vehicles, particularly with carbureted engines, provide a Road Test mode of ECM operation but do not transmit data. For these vehicles, a Road Test (No C&D) selection is available on the menu.

10.1.5 Field Service Functional Tests

**NOTE:**

Operations described in this section are not available on all tool platforms.

The Field Service functional test is available for some 1980½ –95 Isuzu models with General Motors control systems.

Selecting Field Service opens a confirmation screen, accepting the confirmation begins the test.

IMPORTANT:

Do not enter Field Service mode while driving a vehicle on a road test. ECM changes to ignition timing, fuel delivery, and other engine functions may affect engine operation and vehicle control.

In Field Service mode, the scan tool grounds the diagnostic pin B in the ALDL connector. The ECM does not transmit data in this mode, and new trouble codes cannot be set. On some models, Field Service can be selected to check or adjust ignition timing or the idle minimum air rate.

With the key on and the engine off, the instrument panel Check Engine lamp flashes stored trouble codes if any are present or code 12 if no codes are present. The ECM also energizes all solenoids, so you can use Field Service mode to test solenoid operation.

Field Service mode works differently depending on the engine:

- With a carbureted engine running, the Check Engine lamp stops flashing code 12 and new trouble codes cannot be set. The ECM also sets ignition timing to a fixed degree of advance, which lets you check and adjust timing for some models. You also can use the Field Service mode for a system performance check on a carbureted engine. Refer to a vehicle service manual for details.
- For some fuel-injected engines, the instrument panel Check Engine lamp flashes rapidly when the engine is running in open loop and slowly when in closed loop. Additionally, in closed loop, the length of the lamp flash indicates whether the exhaust is rich or lean. The lamp flash is longer if the exhaust is rich.

10.2 Testing Antilock Brake System (ABS)

Isuzu ABS testing includes:

- “ABS Code Reading Connectors and Locations” on page 88
- “Manual Code Reading (ABS)” on page 90
- “Clearing ABS Codes” on page 93

10.2.1 ABS Code Reading Connectors and Locations

Refer to Figure 10-15 and Table 10-4 for common Isuzu ABS diagnostic connector locations.

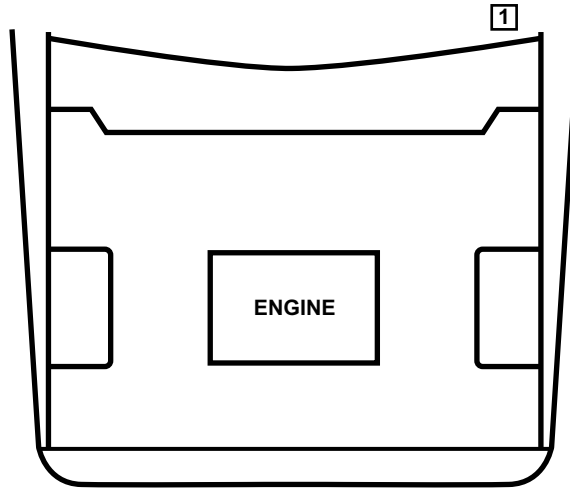

Figure 10-15 Isuzu common ABS connector locations

Table 10-4 Common ABS connector location

VEHICLE	YEAR	CONNECTOR LOCATION
Amigo	1990–94	1
Impulse	1990–92	1
Pickup	1990–95	1
Rodeo	1990–95	1
Stylus	1990–93	1



To read ABS codes from 2003–06 Ascender, 2006 I-280 and I-350:

- Connect the OBD-II adapter to the 16-pin connector (Figure 10-16).

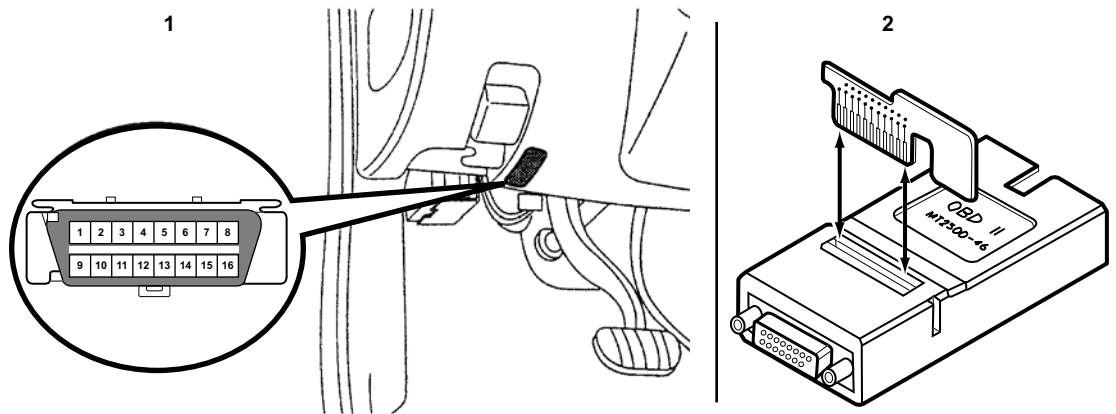

- 1— 16-pin DLC
- 2— OBD-II adapter

Figure 10-16 2003–06 Ascender, 2006 I-280 and I-350 ABS connector

10.2.2 Manual Code Reading (ABS)

There are 3 types of manual ABS codes for Isuzu vehicles:

- Rear wheel antilock (RWAL), see Figure 10-18 and Table 10-5 on page 90
- Type 02, see Figure 10-20 and Table 10-6 on page 91
- Type 05a, see Figure 10-22 and Table 10-7 on page 92

RWAL ABS Code Type

The RWAL diagnostic connector location is shown in (Figure 10-17).

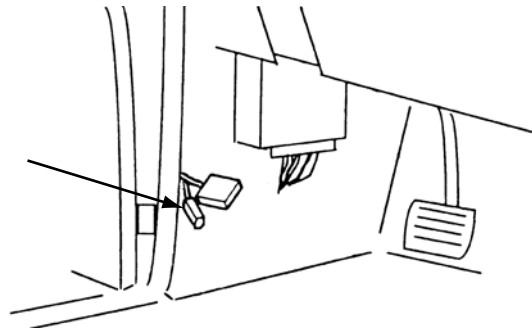

Figure 10-17 1991–95 Rodeo, 1990–95 Pickup, and 1992–94 Amigo 1-pin RWAL diagnostic connector

Straight Count—Flashes the lamp or LED the number of times equal to the trouble code with a noticeable pause between multiple codes. The first flash may be long or short depending on when diagnostics were entered. Include long or short first flash as part of count. For example: a long first flash and seven equal flashes or eight equal flashes is code 8.

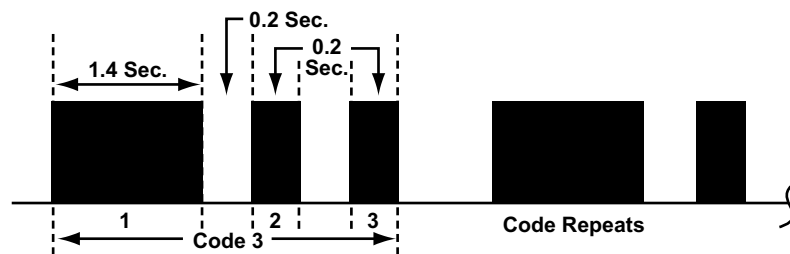

Figure 10-18 Isuzu RWAL ABS Code Type

Table 10-5 Isuzu RWAL ABS Code Type

Pattern:	Straight Count
Read codes on:	Rr Antilock or ABS indicator lamp
Start codes by:	With ignition switch on and indicator illuminated, jumper ABS diagnostic connector terminal to ground. First flash may be long or short. Include the long or short first flash as part of code number count. (Figure 10-17)
Clear codes by:	Codes are cleared every time the ignition key is turned off.
When done:	Disconnect jumper & turn ignition off.
Only the first fault that occurred during the current ignition cycle will set a code. Vehicle may need to be driven to cause some codes to set & turn on the indicator.	

Code Type 02

The diagnostic connector and warning lamp locations are shown in (Figure 10-19).

Long/Short—Indicator flashes a 2-digit trouble code with the 10s digit pulses staying on longer than the 1s digit pulses.

For example: Long–Long–pause–Short–Short–Short is code 23.

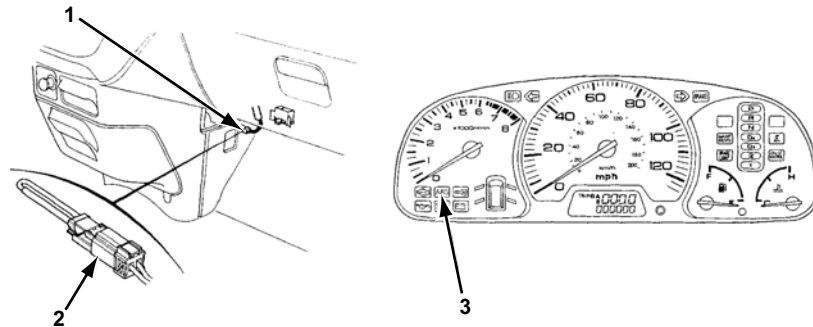

- 1— 2-Pin Service Check connector
- 2— Special tool (O7PAZ-0010100) or equivalent
- 3— SRS indicator lamp

Figure 10-19 1996-1999 Isuzu Oasis ABS service check connector location

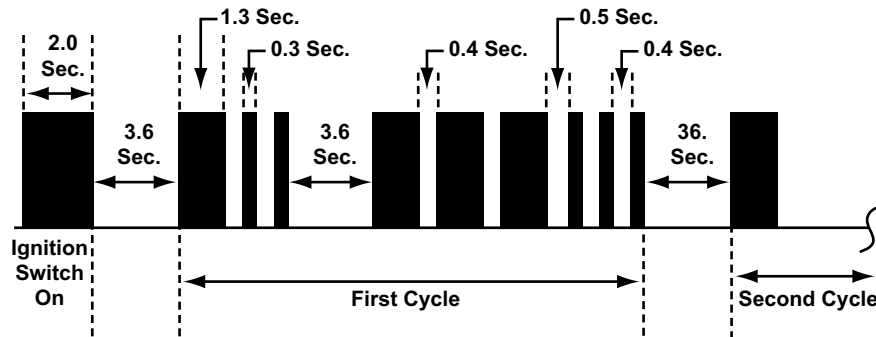

Figure 10-20 Isuzu ABS Code Type 02

Table 10-6 Isuzu ABS Code Type 02

Pattern:	Long/Short (Main code/sub-code)
Read codes on:	ABS indicator lamp
Start codes by:	With ignition switch off, connect SCS service connector (OEM#07PAZ-0010100) or jumper wire to 2-pin ABS service connector. Turn ignition switch on without the brake pedal depressed. Depressing brake pedal will initiate DTC erasure mode.
Clear codes by:	Follow the procedure in the “Clearing ABS Codes” section of this manual. Procedure includes connecting the SCS service connector or jumper wire to the 2-pin ABS service check connector, pressing & releasing the brake pedal several times while monitoring the ABS indicator lamp.
When done:	Turn the ignition off and disconnect the SCS service connector or jumper wire.

Code Type 05a



To read ABS codes from an 2002–04 Axiom, 1996–2002 Trooper, 1999–2001 Rodeo or 1999–2001 Vehicross:

- Jump pins 4 and 12 as shown in Figure 10-21.

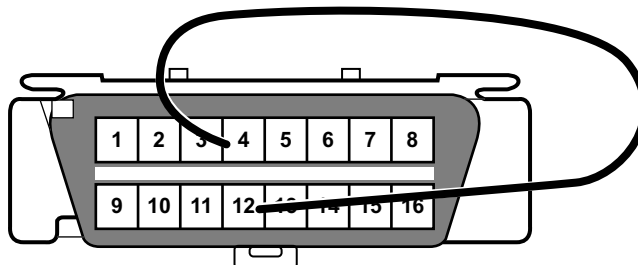

Figure 10-21 16-pin connector jump wire

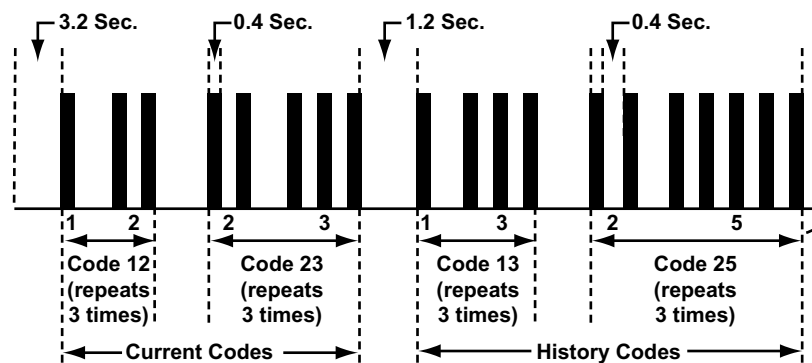

Figure 10-22 Isuzu ABS Code Type 05a

Table 10-7 Isuzu ABS Code Type 05a

Pattern:	10s and 1s
Read codes on:	ABS warning lamp
Start codes by:	After bringing the vehicle to a complete stop, and making sure the brake pedal is not depressed, turn the ignition switch to the off position. Connect terminals 12 and 4 on the OBD-II 16-pin diagnostic link connector (Figure 10-16). Turn the ignition switch to the on position.
Clear codes by:	Within three seconds after entering the diagnostic mode, pulsate the brake switch on and off at least six times.
When done:	Turn the ignition off, disconnect the connectors, and clear codes.
<p>All codes repeat 3 times and are followed by a 1.2 second pause. Code 12 always flashes first to confirm the system is in the diagnostic mode. Any current codes follow code 12. After the current codes have flashed, code 13 may flash. Code 13 indicates the presence of history codes which then follow. If only historical codes are present, the diagnostic sequence first flashes code 12, then code 13, followed by the historical codes. The code display cycle repeats as long as the system is in the diagnostic state.</p>	

10.2.3 Clearing ABS Codes

Use this procedure to clear ABS codes on the 1996–99 Isuzu Oasis.

The following conditions must be met before DTC erasure mode will complete:

- The SCS check connector or jumper wire must be connected to the 2 pin service connector before the ignition switch is turned on. See Figure 10-19 on page 91 for connector location.
- The brake pedal must be depressed before the ignition switch is turned on.
- Vehicle speed must be 6 mph (10kph) or less.



To clear ABS codes:

1. Connect the SCS service connector to the 2-pin service connector located under the glove box. (See Figure 10-19 on page 91)
2. Depress the brake pedal.
3. Turn the ignition switch On while keeping the brake depressed.
4. After the indicator comes on, depress the brake pedal again.
5. After the indicator goes off, release the brake pedal again.
6. After a few second, the ABS indicator blinks twice and the DTC is erased. If the indicator does not blink twice, repeat steps 1 through 6. if the indicator stays on after the indicator blinks twice, check the DTC because a problem was detected during the initial diagnosis before shifting to DTC erasure mode.
7. Turn the ignition switch off and remove the SCS service connector.

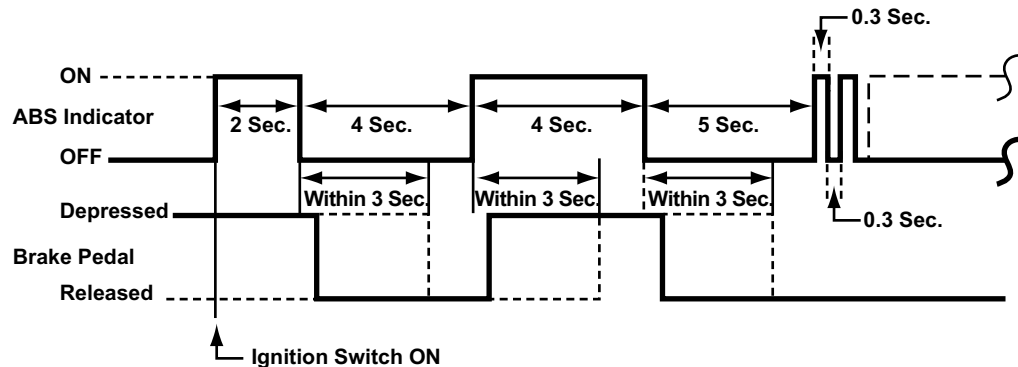

Figure 10-23 1996–99 Isuzu Oasis ABS DTC erasure mode

10.3 Testing Supplemental Restraint Systems (SRS)

Isuzu SRS, or airbag testing includes:

- “Manual Code Reading (SRS)” on page 94
- “Clearing SRS Codes” on page 97

10.3.1 Manual Code Reading (SRS)

Isuzu models use 2 types of SRS codes:

- Type 02a, see Figure 10-25, Figure 10-26 and Figure 10-27 and Table 10-8 on page 95
- Type 03, see Figure 10-28 and Figure 10-29 and Table 10-9 on page 96

Code Type 02a

Long/Short - Flashes a 2 digit trouble code with the 10s digit pulses staying on longer than the 1s digit pulses.

For example: Long–Long–pause–Short–Short–Short is Code 23.

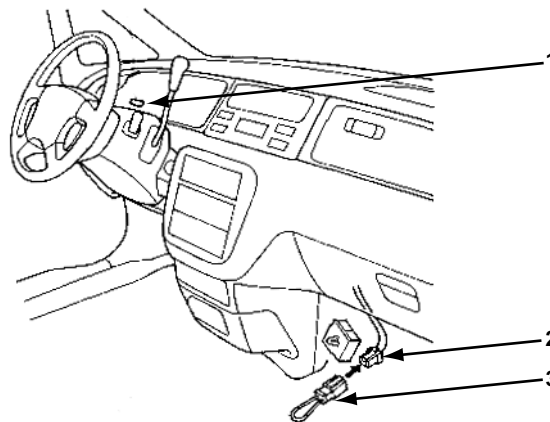

- 1— SRS indicator lamp
- 2— 2-Pin Service Check connector
- 3— Special tool (O7PAZ-0010100) or equivalent

Figure 10-24 Isuzu 1996–99 Oasis 2-pin service check connector location

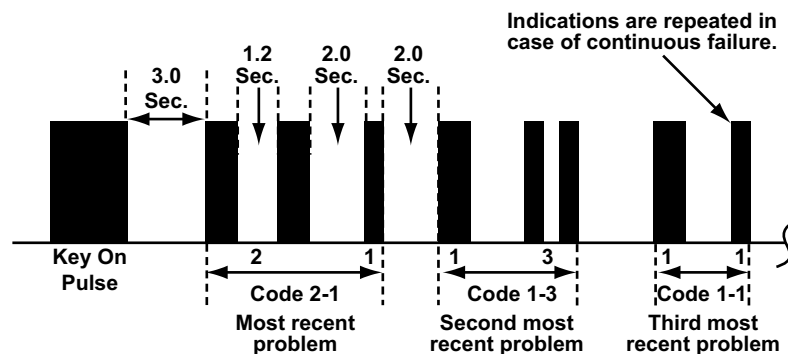

Figure 10-25 Isuzu SRS Code Type 02a: Continuous Failure, SRS indicator flashes like this

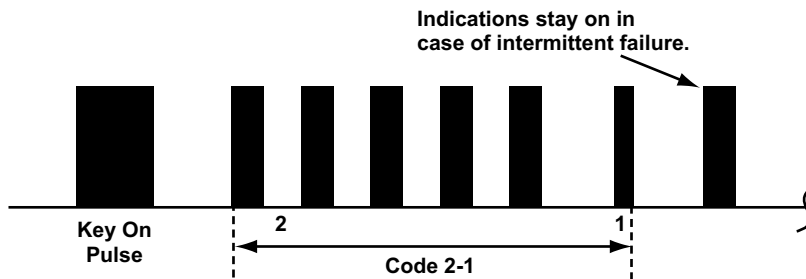

Figure 10-26 Isuzu SRS Code Type 02a: Intermittent Failure, SRS indicator flashes like this

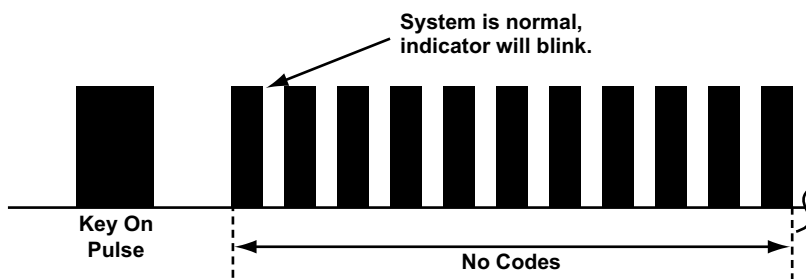

Figure 10-27 Isuzu SRS Code Type 02a: Normal (no failure), SRS indicator flashes like this

Table 10-8 Isuzu SRS Code Type 02a

Pattern:	Long/Short (Main code/sub-code)
Read codes on:	SRS indicator lamp
Start codes by:	With ignition switch off, connect SCS service connector (OEM# 07PAZ-0010100) or jumper wire to the 2-pin service check connector. Turn ignition switch on.
Clear codes by:	Following the procedure in the “Clearing SRS Codes” section of this manual. Procedure includes connecting and disconnecting the SCS service connector or jumper wire to the MES (Memory Erase Signal) connector several times while monitoring the SRS indicator flashes.
When done:	Switch the ignition off and wait two to three seconds. Turn the ignition switch on again. The SRS indicator light should come on and go out after about six seconds. Continue to monitor the SRS indicator and confirm that it does not come on again for another 30 seconds. Turn ignition switch off.

Turn the ignition switch on. The SRS indicator light comes on for about six to thirty seconds and goes off. Shortly after (the time depends on which DTC is confirmed by the self-diagnosis system), it will indicate the DTC.

- In case of continuous failure(s), the DTC(s) will be indicated repeatedly (see Figure 10-25).
- In case of intermittent failure(s), the SRS indicator light will indicate (each of) the DTC(s) one time, then it will stay on (see Figure 10-26).
- In case of both continuous and intermittent failures, the DTC of the continuous failure only is indicated repeatedly. After troubleshooting it, first recheck to make sure that the problem has disappeared and that there are no other codes. Then, erase the codes from memory.
- In case the system is normal (no DTC), the SRS indicator light blinks (see Figure 10-27).

Code Type 03

Tens/Ones - Flashes a 2 digit trouble code with a noticeable pause between each digit. The first set of flashes is the 10s digit; the second set of flashes is the 1s digit.

For example: Flash–Flash–pause–Flash–Flash–Flash is Code 23.

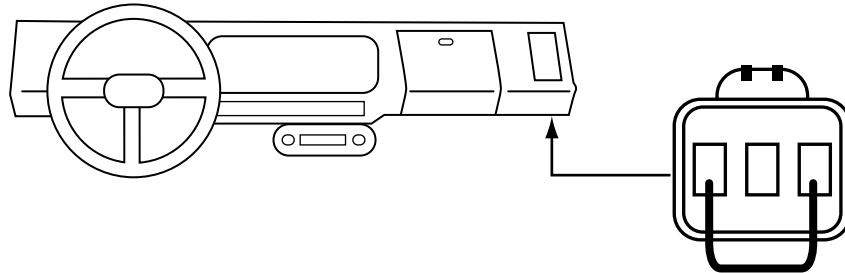

Figure 10-28 Isuzu vehicles with orange SRS diagnostic connector and jumper pins

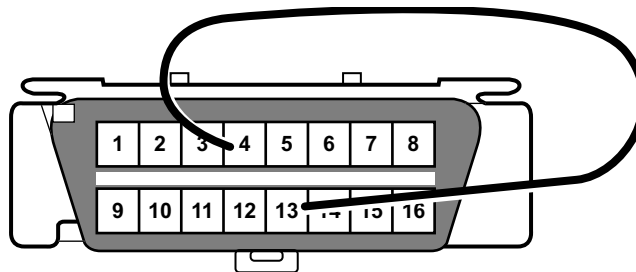
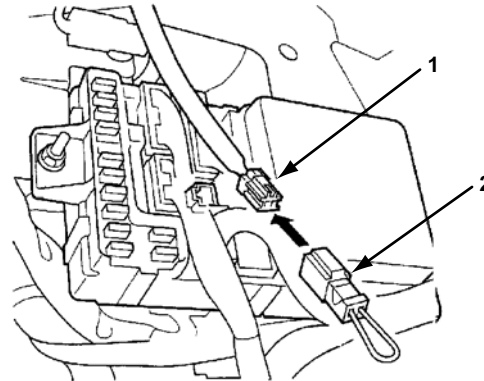

Figure 10-29 1996 and newer Isuzu vehicles with 16-pin OBDII style connector and jumper wire

Table 10-9 Isuzu SRS Code Type 03

Pattern:	10s and 1s
Read codes on:	INFL REST or SRS indicator lamp
Start codes by:	With ignition switch on, jumper two terminals in a diagnostic connector together. Only current codes will be flashed. (Figure 10-28, Figure 10-29)
Clear codes by:	Codes cannot be cleared manually on these vehicles. A factory scan tool must be used to clear SRS codes.
When done:	Disconnect jumper & turn ignition off.
<p>Each code is displayed one time before moving on to the next code. After all of the codes have displayed, the entire code sequence will repeat until the jumper wire is removed from the diagnostic connector.</p> <p>Flash code 12 should always be the first code to flash, which indicates that flash code mode has been enabled. If there are no current or history codes, flash code 12 will be flashed until the jumper is removed from the diagnostic connector.</p> <p>Flash code 13 indicates that History codes are stored in memory. A factory scan tool is needed to read history codes.</p>	

10.3.2 Clearing SRS Codes



1— MES (Memory Erase Signal) connector

2— SCS service connector

Figure 10-30 1996–99 Oasis SRS code clearing (left side of dash)



To clear SRS Codes on 1996–99 Isuzu Oasis models:

1. Switch the ignition off and disconnect the SCS connector from the service check connector.
2. Connect the SCS service connector (part number 07PAZ-0010100) to the yellow 2-pin MES (Memory Erase Signal) connector. A common jumper wire can be used, as long as you maintain good contact between the terminals.
3. Switch the ignition on. The SRS indicator lamp lights for about 6 seconds and then goes off.
4. Within 4 seconds of the lamp switching off, remove the SCS service connector from the MES connector.
5. When the SRS indicator lamp lights again, connect the SCS service connector to the MES connector within 4 seconds of the lamp switching on.
6. Within 4 seconds of the lamp switching off, remove the SCS service connector from the MES connector. The SRS lamp flashes twice to indicate memory has been erased.
7. Switch the ignition off and wait two to three seconds.
8. Turn the ignition switch on again. The SRS indicator light should come on and go out after about 6 seconds. Continue to monitor the SRS indicator and confirm that it does not come on again after 30 seconds.
9. Turn ignition switch off.

10.4 Testing Transfer Case, Body Control Module (BCM), and Instrument Panel Cluster (IPC) Control Systems

The OBD-II data link connector (DLC) is the used for testing the transfer case, BCM, and IPC.

This chapter contains information for testing Kia vehicles with the Asian Import Vehicle Communication Software (VCS). The following Kia systems may be available for testing:

- Engine
- Transmission
- Antilock Brake System (ABS)
- Airbag

11.1 Testing Engine, Transmission, and Antilock Brake Systems

Kia engine, transmission, ABS, and airbag testing includes:

- “Code Reading” on page 98
- “Manual ABS Code Reading” on page 101

11.1.1 Code Reading



To read engine codes with a 20-pin connector:

- Connect the MULTI-1 adapter with red terminal converters as shown in Figure 11-1 (red lead to terminal 19, blue lead to terminal 11, and black lead to terminal 4 or 12).

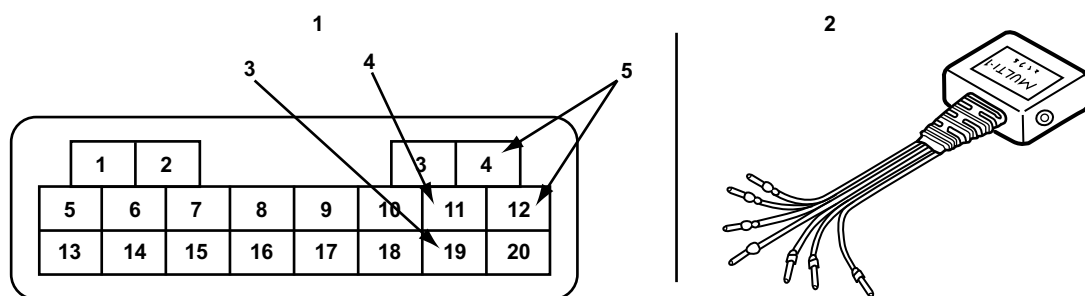

- 1— 20-pin connector
- 2— MULTI-1 adapter
- 3— Red MULTI-1 wire
- 4— Blue MULTI-1 wire
- 5— Black MULTI-1 wire

Figure 11-1 20-pin DLC and MULTI-1 adapter—engine codes



NOTE:

Count long pulses as tens and short pulses as ones.



To read transmission codes with a 20-pin connector:

- Connect the MULTI-1 adapter with red terminal converters as shown in Figure 11-2 (red lead to terminal 18, blue lead to terminal 11, and black lead to terminal 4 or 12).

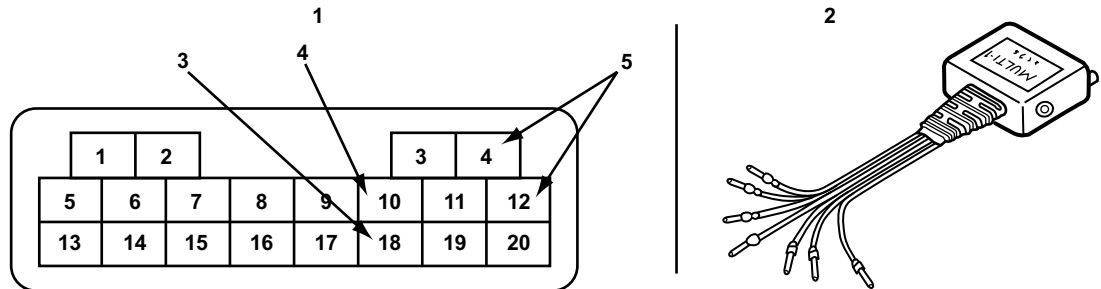

- 1— 20-pin connector
- 2— MULTI-1 adapter
- 3— Red MULTI-1 wire
- 4— Blue MULTI-1 wire
- 5— Black MULTI-1 wire

Figure 11-2 20-pin DLC and MULTI-1 adapter—transmission codes



To read engine, transmission, ABS, and airbag codes, data, and functional tests (where applicable) from vehicles with a 16-pin connector:

- Use the OBD-II adapter with the specified Personality Key™ device (Figure 11-3).

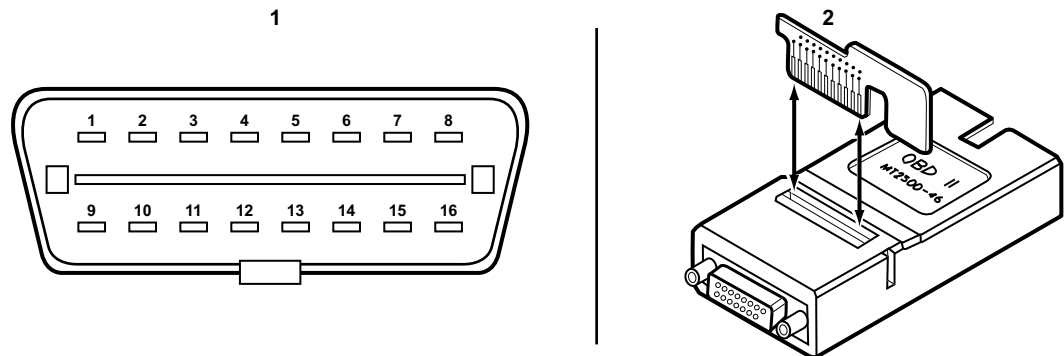

- 1— 16-pin DLC
- 2— OBD-II adapter

Figure 11-3 16-pin DLC and OBD-II adapter



To read 1994–2001 Sportage ABS codes:

- Ground terminal 1 as shown in Figure 11-4 on page 100.

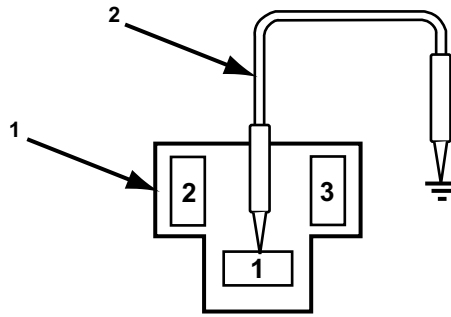

- 1— 3-pin connector
- 2— Fused jump wire

Figure 11-4 1994–2001 Sportage 3-pin ABS check connector



To read 2001–2002 Rio and 1995–97 Sephia ABS codes:

- Connect pin 8 to ground (pins 4 or 12) as shown in Figure 11-5.

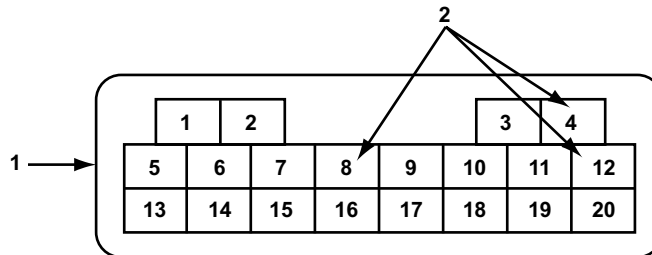

- 1— 20-pin connector
- 2— Jump wires

Figure 11-5 20-pin DLC—jump pins for ABS codes



To read 2000–01 Spectra and Sephia ABS codes:

- Connect pin 16 to ground (pins 4 or 12) as shown in Figure 11-6.

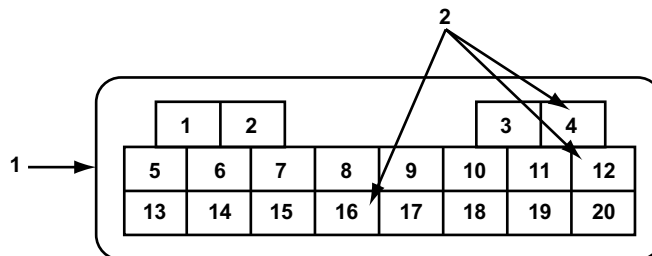

- 1— 20-pin connector
- 2— Jump wires

Figure 11-6 20-pin DLC—jump pins for ABS codes

11.1.2 Manual ABS Code Reading

Kia ABS transmits Type 13 manual codes, see Figure 11-7 and Table 11-1.

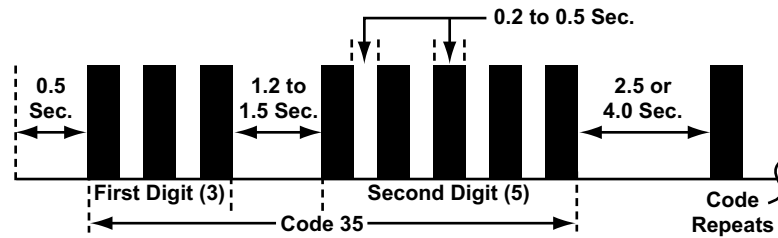

Figure 11-7 *Kia ABS Code Type 13*

Table 11-1 *Kia ABS Code Type 13*

Pattern:	Straight count
Read codes on:	Flashes ABS lamp
Start codes by:	Jumper the ABS and ground terminals in the 20-pin connector or jumper Terminal 1 to ground in the 3-pin ABS connector.
When done:	Turn the ignition off and clear codes.
After fixing problem, clear codes and drive car; then check for other codes.	

This chapter contains information for testing Mazda vehicles with the Asian Import Vehicle Communication Software (VCS). The following Mazda systems may be available for testing:

- Engine
- Transmission
- Antilock Brake System (ABS)
- Airbag
- Electric Automatic Temperature Control (EATC)
- Electronic Power Steering (EPS)
- Generic Electronic Module (GEM)
- Instrument Cluster Module (ICM)
- Parking Aid Module (PAM)
- Tire Pressure Monitor (TPM)
- Transfer Case (4x4M)

12.1 Testing Engine and Transmission Systems

Mazda engine and transmission system testing includes:

- “Code Reading” on page 102
- “Manual Code Reading” on page 103
- “Functional Tests—1983–95 models” on page 104
- “Functional Tests—All models with EEC-IV and EEC-V systems” on page 105
- “Transmission Code Retrieval—1987 626” on page 110

12.1.1 Code Reading



To read codes from vehicles with a 16-pin connector:

- Use the OBD-II adapter with the specified Personality Key™ device (Figure 12-1).

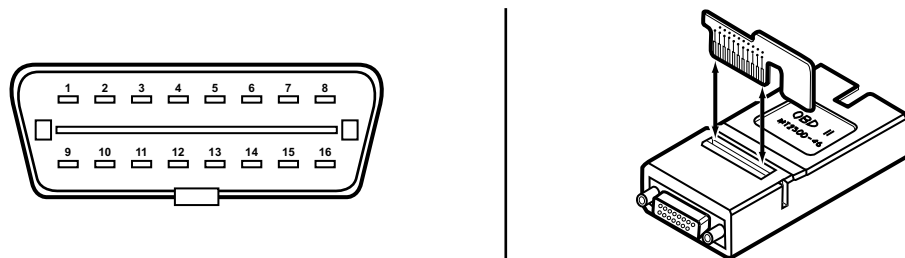

Figure 12-1 16-pin connector and OBD-II adapter with Personality Key™ device



To read engine and transmission codes from a 17-pin underhood connector:

- Connect the MAZDA-1 adapter to the 17-pin connector (Figure 12-2). For reading codes manually, ground one of the following pins:
 - TEN = Engine codes
 - TAT = Transmission codes (most cars)

IMPORTANT:

Grounding the incorrect pin may result in vehicle damage.

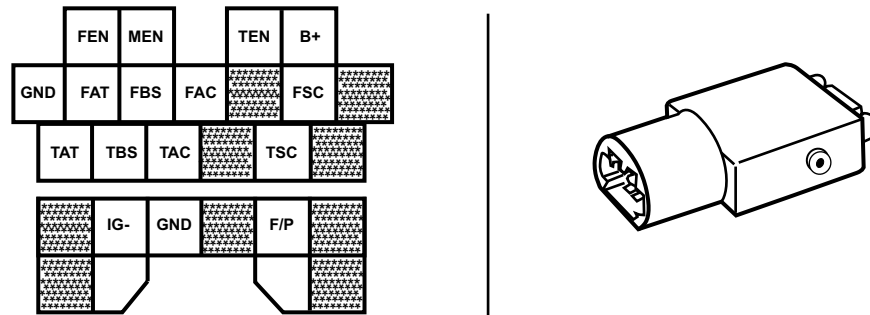

Figure 12-2 17-pin underhood connector and MAZDA-1 adapter



To read codes from vehicles with 6-pin and 1-pin connectors:

- Use the MULTI-2 adapter (Figure 12-3).

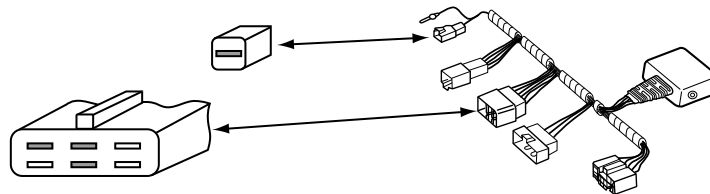

Figure 12-3 6-pin and 1-pin connectors and MULTI-2 adapter

IMPORTANT:

When connecting to a vehicle with the above configuration, make sure the 1-pin connector is properly identified. Failure to identify the right connector may result in scan tool damage.



NOTE:

Some vehicles retrieve transmission codes from the engine control module (ECM).

12.1.2 Manual Code Reading

Refer to Figure 12-4 for reading manual codes.

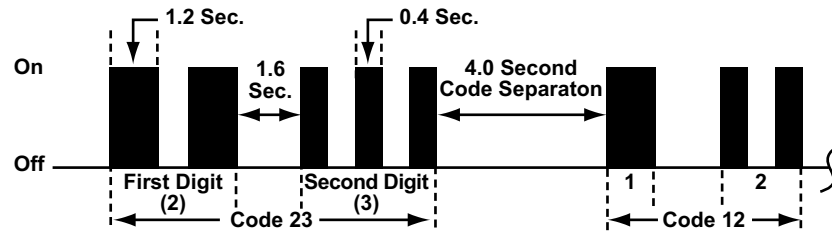

Figure 12-4 Mazda engine, transmission, and ABS flash codes

12.1.3 Functional Tests—1983–95 models

These functional tests apply to all models except:

- 1991–94 Navajo
- 1994 B-Series
- 1994–95 626 with 2.0L engine and automatic transmission



NOTE:

Operations described in this section are not available on all tool platforms.

The following Functional Tests may be available for 1983–95 Mazda vehicles.

- **Oxygen Sensor Test**—monitors the feedback signal from the oxygen sensor (O2S).
- **Switch Test**—checks certain switch circuits.
- **Base Timing Check**—commands the ECM to place the engine in the base timing mode for ignition timing checks and adjustments.



To perform an oxygen sensor test:

1. From the Functional Tests menu, select **Oxygen Sensor Test**.
2. Start and run the engine to warm it to normal operating temperature.
3. Select to initiate the test.
4. As instructed, accelerate the engine and hold it at 2000 RPM.

Lean and Rich indicate the condition of the exhaust. LED 3 flashes to indicate that the scan tool is receiving a signal from the exhaust gas oxygen sensor.



To perform a switch test:

1. From the Functional Tests menu, select **Switch Test**.
2. Select to initiate the test.



NOTE:

Not all switches displayed apply to every vehicle. Refer to Mazda service procedures and specifications for availability of specific switch tests.

As you test each switch, the Switch State parameter should alternately display High or Low each time a switch status changes. Also, LED 4 turns on when this parameter displays Low, and off when High. See Table 12-1 for individual switch test instructions.

Table 12-1 Individual switch test instructions

SWITCH	TEST INSTRUCTIONS
Clutch	With the key on and engine off, Switch State alternates High/Low as the clutch is depressed and released.
Neutral	Switch State alternates High/Low when switching from a drive state to a park/neutral state.
Inhibitor	(A/T only) Make sure the engine is off. Switch State alternates High/Low as the transmission is placed in gear and returned to neutral.
Idle	Switch State alternates High/Low as the accelerator pedal is pressed and released.
Head lamp	Switch State alternates High/Low as the head lamps are turned on and off. Turn off the head lamps after the test.
Brake Lamp	Switch State alternates High/Low as the brake pedal is pressed and released.
Blower	Turn the blower switch to the high position. Switch State alternates High/Low as the blower switch position changes. Turn the blower off after the test.
A/C	With the blower set to low, Switch State alternates High/Low as the A/C is turned on and off. Turn off the blower and air conditioner after the test.
Rear Defroster	Switch State alternates High/Low as the rear defroster is turned on and off. Turn off the rear defroster after the test.
Water Thermo	Switch State alternates High/Low as the water thermo switch is disconnected. Reconnect the switch after the test.

NOTE:

If coolant is at operating temperature, the LED is always on.

**To perform a Base Timing Check:**

- From the Functional Tests menu, select **Base Timing Check**.
The ECM enters base timing mode to allow ignition timing checks and adjustments.

12.1.4 Functional Tests—All models with EEC-IV and EEC-V systems

NOTE:

Operations described in this section are not available on all tool platforms.

Functional Tests are available for Mazda vehicles with EEC-IV and EEC-V control systems, but menu items are completely different for each system. See “EEC-IV Functional Tests” on page 106 and “EEC-V Functional Tests” on page 109 for details.

NOTE:

The ignition key should be switched off when selecting Functional Tests from the Main Menu - PCM on EEC-IV and EEC-V vehicles.

EEC-IV Functional Tests

**NOTE:**

Operations described in this section are not available on all tool platforms.

EEC-IV systems typically offer several functional tests, the following EEC-IV functional tests are described in this section:

- “Computed Timing Test” on page 106
- “Wiggle (Engine Off) Test” on page 106
- “Wiggle (Engine Running) Test” on page 107
- “Output State Check” on page 107
- “Idle Speed Adjustment Test” on page 108

Computed Timing Test

This test checks ignition timing with the engine running at a controlled idle speed. It also verifies the ability of the PCM to advance and retard timing. Connect either a timing light or a magnetic timing meter to the engine before testing.

On most EEC-IV engines, the PCM advances timing 20° above the base timing setting. So if the base timing specification is 10° BTDC, expect to read 30° BTDC with a timing light or meter. Refer to Mazda service manuals for timing specifications and test procedures.

**To conduct a Computed Timing test:**

1. Select **Computed Timing**.
The “timing check” screen displays.

**NOTE:**

A “warning” message displays if the timing check test is selected with the engine running or with the ignition switch on. This means the PCM self-test output (STO) circuit is still energized from a previous test. On some vehicles, this message can be ignored. If uncertain, turn the key off, wait 10 seconds, restart the engine, then enter the test.

2. With the engine warm and running at idle, select to start the test.
3. Check the timing with a timing light or timing meter within 2 minutes.

Wiggle (Engine Off) Test

This test puts the EEC-IV system into a program that records intermittent service codes that occur as you wiggle or tap on various engine sensors, actuators, and wiring connectors with the ignition on and the engine off.

**To conduct a Wiggle (Engine Off) test:**

1. Select **Wiggle (Engine Off)**.
The test initiation screen displays.
2. Switch the key on and select to continue.
After a brief startup message, the test displays.

3. Wiggle or tap the engine sensors, actuators, and wiring connectors.

The bottom line of the screen is blank until a fault occurs and a code sets. If a code sets, the bottom line displays a “memory code stored–run KOEO test” message. Always check for memory DTCs after a wiggle test.

**NOTE:**

Do not wiggle the test adapter loose from the self-test connector during this test or a false code may set. Always exit the test before turning off the ignition or a false code may result.

**To read the service codes from a wiggle test:**

- Select **Codes Menu > KOEO Self-Test.**

Wiggle (Engine Running) Test

This test places the EEC-IV system into a mode that records intermittent service codes as you wiggle or tap on engine sensors, actuators, and wiring connectors with the engine running.

**To conduct a Wiggle (Engine Running) test:**

1. Select **Wiggle (Engine Running)**.
The test instruction screen displays.
2. If the engine is running, a warning message displays. Switch the engine off, wait 10 seconds, then restart the test. Otherwise, start and run the engine at idle speed.
3. Once the engine is fully warm, select to enter the test.
The screen momentarily displays a test initiated message, then switches to the test screen.
4. Wiggle or tap on sensors, actuators, and wiring connectors.
The bottom line of the screen is blank until a fault occurs and a code sets. When a code sets, the bottom line reads “memory code stored–run KOEO test,” but this message only appears during a fault. Always check for memory DTCs after a wiggle test.

**NOTE:**

Do not wiggle the test adapter loose from the self-test connector during this test, or a false code may set. Always exit the test before turning off the ignition.

**To read the service codes from a wiggle test:**

- Select **Codes Menu > KOEO Self-Test.**

Output State Check

This test allows you to switch the PCM signals to the engine actuators on and off to take voltmeter readings. If the engine is running, turn it off before selecting the output state test.

**NOTE:**

The EEC-V Output State Test is the same as the EEC-IV Output State Check, the test name is the only difference; the function is the same.

**To conduct an output state test:**

1. Select **Output State Check**.
The test initiation screen displays.
2. Select to imitate the test, then switch the ignition on without starting the engine.

IMPORTANT:

When the test begins, all actuators (except IAC and fuel injectors) should be off and the PCM circuits from the should be high (above 10 V). Use the DVOM or lab scope to check actuators.

A “self-test initiated” screen displays, followed by the test screen.

3. Press the accelerator to wide open throttle (WOT) to switch all engine actuators from off to on, or from on to off.

All of the actuators stay on or off until the throttle is pressed again. As the actuators change state, the bottom line of the display shows if they are on or off.

Idle Speed Adjustment Test

This test allows you to adjust the idle speed for certain 1991 and later engines. Before adjusting idle speed, make sure the throttle body and idle speed control (ISC) device are clean, and the throttle linkage is not sticking or binding.

Also, switch all accessories off and make sure the O2S is working properly, ignition timing is correct, and there are no vacuum leaks. Place the transmission in park or neutral before selecting the test.

A command from the scan tool starts the engine-running test, and a signal from the EEC-IV PCM indicates when the test is complete. During this waiting period, the cylinder identification displays along with instructions to press the brake pedal, turn the steering wheel, or snap the throttle. These actions are not necessary, however, doing them speeds the self-test.

IMPORTANT:

If any service codes other than “11—no faults present” are displayed after the engine-running test, correct any code problems before proceeding with the idle adjustment.

**To conduct an idle speed adjustment test:**

1. Select **Idle Speed Adjust**.
The test initiation screen displays. If another test was performed before this one, a “warning” screen may display because the self-test output (STO) circuit is still energized from the previous test. For some vehicles, it is safe to ignore this message and enter the test. If you are uncertain, turn the key off, wait 10 seconds, and restart the engine before entering the test.
2. Start the engine and run at 2000 RPM for two minutes.
A timer displays in the lower right corner of the screen. Skip this warm-up if the engine is already warm.
3. Select and the “test initiated” screen displays.
Once the test is complete, the scan tool sends a start-idle-test signal to the PCM. The screen changes as the scan tool waits for a response from the PCM.
After the PCM response is received, the throttle stop screw adjustment screen displays. The display indicates if idle speed is too high, too low, or correct. If the display reads “TPS out of

adjustment—fix first,” the throttle position sensor must be fixed to proceed. If idle speed is correct, skip to the last step.

Ten minutes after the idle speed test signal is received, the PCM stops communicating. Normally, this is enough time to complete the adjustment. If not, return to the Functional Tests menu, select, and repeat the test.

4. Turn the throttle stop until “idle RPM correct” displays.
5. Select to accept when the idle RPM is correct.
An instruction and verification screen displays.
6. Run the engine at 1500 RPM for 10 seconds, return to idle, and press **Y**.
7. An idle RPM correct message should display. If not, repeat the idle speed adjustment.
8. When the idle is properly adjusted, exit the test.

EEC-V Functional Tests



NOTE:

Operations described in this section are not available on all tool platforms.

The following EEC-V functional tests are described:

- “Output State Test” on page 109
- “Module Identification Test” on page 110



NOTE:

The ignition key should be switched off when selecting Functional Tests from the Main Menu - PCM on EEC-V vehicles.

Output State Test

This test lets you switch PCM signals to the engine actuators on and off for testing with a DVOM or lab scope. The engine must be off before the test is selected.

During a test, actuators stay on or off until you switch them. Actuators default to their normal state after 10 minutes, if the vehicle is started, or if the ignition switch cycles off and on.

IMPORTANT:

Make sure the fuel system is intact before proceeding. Selecting All Outputs On causes the electric fuel pump to briefly energize. Also, make sure fan blades are clear of obstruction before selecting low or high speed fan on.



To conduct an output state test:

1. Select **Output State Test**.
A test activation screen displays.
2. Select to activate and the test list displays.
3. Select the desired test.
 - If the vehicle performs the test, “activated” or “fan requested” displays to the right of the selected test.

- If the vehicle does not perform the test, "error" displays to the right of the selected test.
- Take circuit readings while the test is activated.

Module Identification Test

This test displays the PCM software file, part number, and sometimes the vehicle VIN. Select the test and an information screen displays.

12.1.5 Transmission Code Retrieval—1987 626

Gathering codes from a 1987 626 transmission requires taking a reading from two wires on the test connector. This can be performed with a dual trace graphing meter connected as shown in Figure 12-5.

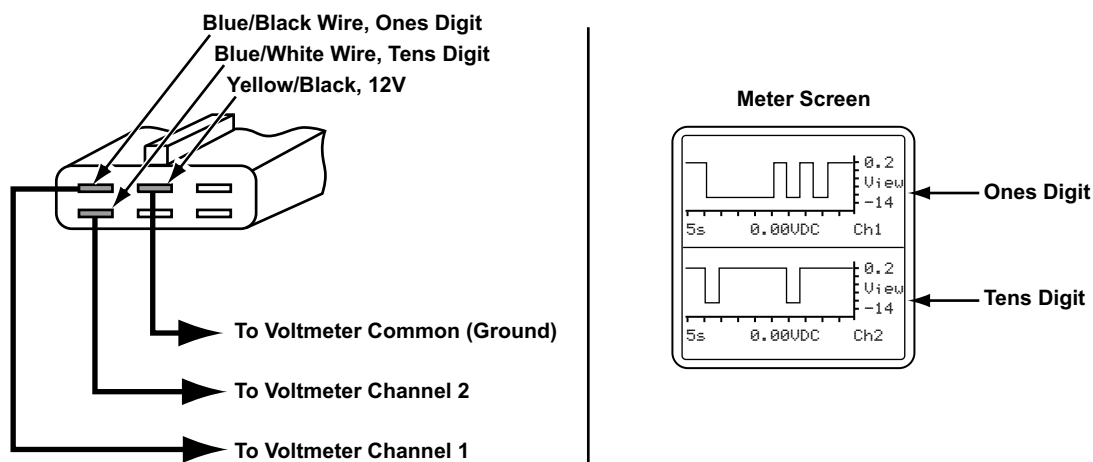

Figure 12-5 Connecting a Dual Trace Graphic Meter to a 1987 626 transmission connection

IMPORTANT:

Be aware that the negative meter lead is connected to a 12 V source on the Y/B (yellow/black) wire; the transmission control module (TCM) grounds the other wires to create the signal. Therefore, the displayed reading is inverted and the ones are the negative transitions.

This test may also be performed with a test lamp. Connect the ground lead of the test lamp to the yellow/black wire and probe the other two wires of the test connector one at a time:

- The blue/white wire displays the tens digit of the code as a 0.4-second flash followed by a 2-second pause. The pattern then repeats. If there is no flash, no tens digit is present.
- The blue/black wire displays the ones digit as either a 2.0-second flash, which is counted as five, or a 0.4-second flash, which is counted as a one.

Combine the two readings, tens and ones, to get a two-digit code (Figure 12-6 on page 111).

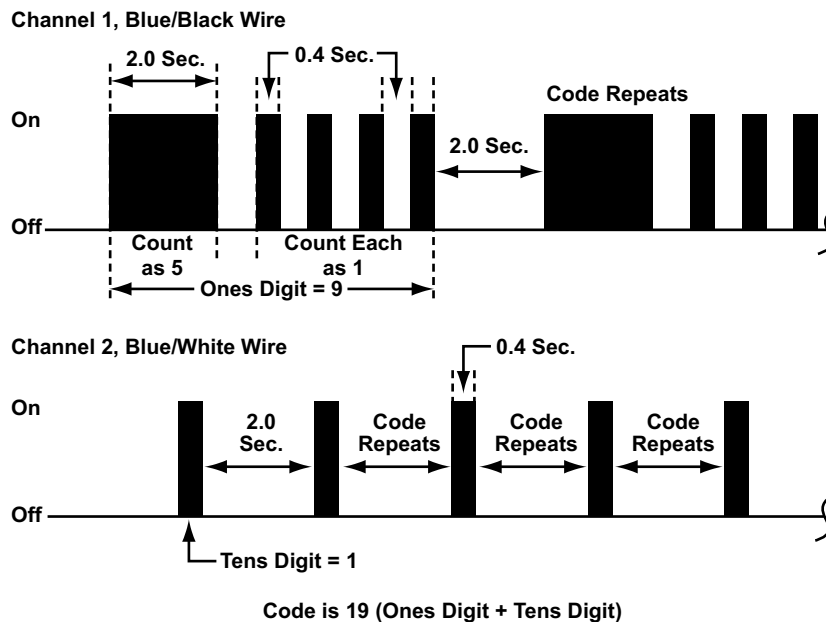

Figure 12-6 1987 626 transmission manual flash codes

12.2 Testing Antilock Brake Systems

When a ABS malfunction occurs, the ABS electronic control module (ECM) illuminates the ABS lamp on the instrument panel. On some systems, the ABS ECM stores codes for most malfunctions, and provides data stream information for some models. Codes transmit to a scan tool through either the OBD-II diagnostic link connector (DLC) or the ABS test connector. Data stream information displays when the ABS control system provides it.



NOTE:

The following sections apply to ABS systems on vehicles with or without traction control.



To read ABS codes from vehicles with a 17-pin underhood connector:

- Connect the MAZDA-1 adapter to the 17-pin connector (Figure 12-7). For reading codes manually, ground the TBS pin.

IMPORTANT:

Grounding the incorrect pin may result in vehicle damage.

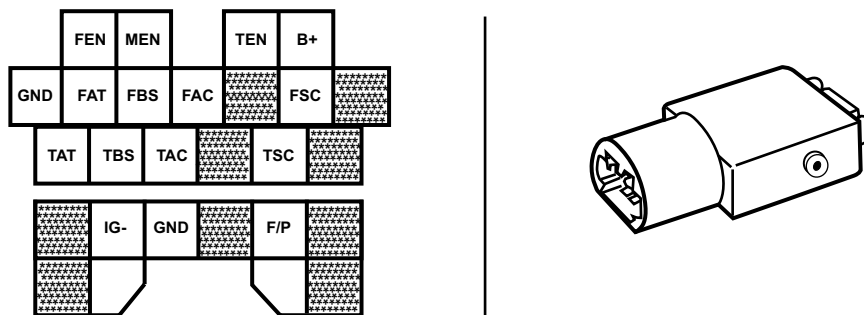
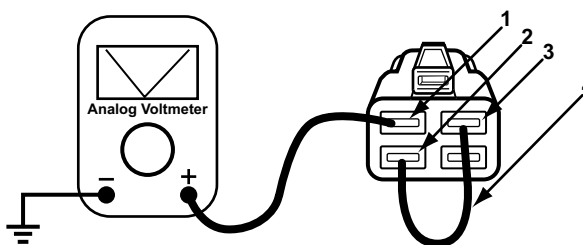

Figure 12-7 17-pin underhood connector and MAZDA-1 adapter



To read 1988–92 626/MX6 ABS codes:

- Connect an analog voltmeter to FBS (G/R) (Figure 12-8).
- Read malfunction code(s) by observing meter needle swings.



- 1— FBS (Green/Red)
- 2— TBS (Green Black)
- 3— GND (Black)
- 4— Jump wire

Figure 12-8 Analog voltmeter and terminal on 1988-1992 626/MX6



To read 1993–94 Navajo 4-Wheel Antilock (4WAL) brakes codes:

1. With the key off, jump the white, light blue, and black wires (Figure 12-9).
2. Turn the key on and remove the jumper within 5 seconds.
3. Count flashes. Code 16 is a system pass.

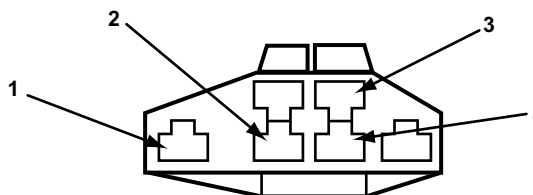

- 1— Black/Light Blue
- 2— Dark Green
- 3— Black
- 4— White/Light Blue

Figure 12-9 1993–94 Navajo with 4WAL



To read 1990–93 B-Series and MPV ABS codes:

1. Attach a jumper wire to Terminal C (yellow wire, Figure 12-10).
Ground the jumper wire to the chassis for one second and release it.

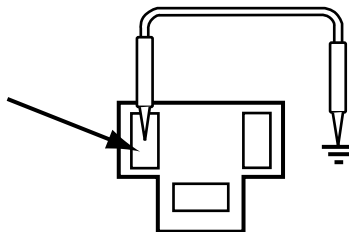

Figure 12-10 Terminal C on 1990–93 B-Series and MPV

2. Count flashes.
A flashing pattern consists of a number of short flashes and ends with a long flash. Count flashes and include the long flash in the count.

IMPORTANT:

Always use a fused jumper wire when connecting to ground.

12.2.1 ABS Main Menu

After selecting ABS from the System Selection menu, the Main Menu - ABS displays. Selections vary by model and year. The following main menu selections are discussed here:

- “Service Codes” on page 113
- “ABS Data Communication Guidelines” on page 116

Refer to the manual for your diagnostic tool for information on other menu options.

Service Codes

During a KOEO self-test, the ABS ECM transmits on-demand codes. On most systems, continuous codes are gathered by selecting MEMORY CODES from the SERVICE CODE Menu. Some systems gather continuous codes automatically after the KOEO self-test.

Select SERVICE CODES and the following choices are available on the SERVICE CODE Menu:

- **KOEO SELF-TEST**—displays on-demand codes present with the ignition on, but the engine not running. These are usually electrical open and short circuits and must be serviced first, before any continuous codes. On some systems, the KOEO test displays continuous codes and the MEMORY CODES selection does not appear on the menu.
- **MEMORY CODES**—displays continuous codes of intermittent faults from the ABS module, when available. Memory codes should be serviced last.
- **Clear Codes**—clears continuous memory codes from the ABS ECM memory.
- **How To Get Codes**—displays how to manually gather and clear RABS codes.
- **Review Codes**—lets you view codes.
- **Print Codes**—lets you print codes.

Any time a self-test is selected, a self-test initiated message displays. This message means the scan tool attempted to start the test, it does not mean the vehicle responded. If the message stays on the screen more than a few minutes, the test probably did not start. Should this happen, exit the test, cycle the ignition key, then retest.

KOEO Self-Test

This selection initiates a self-test for ABS that is similar to that for the engine.



To conduct a KOEO Self-Test:

1. Select **KOEO Self-Test**.
A “key on” verification screen displays.
2. Make sure the ignition is switched on, then select to continue.
The self-test initiated screen displays.



NOTE:

Some systems require the ignition to be cycled on after the test is selected. Follow on-screen screen instructions.

3. At the end of the test, the service code list displays.

Memory Codes

This selection displays the continuous codes of intermittent faults from the ABS ECM. Some models automatically gather memory codes at the end of the KOEO self-test. Continuous codes should be serviced last.



To gather memory codes:

1. Select **Memory Codes**.
A “key on” verification screen displays. Make sure the ignition is switched on.
2. Select to continue.
The self-test initiated screen displays.
When the ABS ECM finishes the test, the service code list displays. If no codes are detected during the test a “P0000 no faults present” message displays.

Clear Codes

This selection erases any continuous codes from the ABS ECM memory.

On some systems, the KOEO test repeats and the scan tool then interrupts the self-test input to clear memory. Some systems require the vehicle to be driven above 25 mph to clear codes.

Note the following when clearing codes:

- Some systems prioritize DTCs. After repairing and clearing a DTC, always recheck for additional faults that may be present.

- Only continuous codes can be cleared. Codes from a KOEO self-test are on-demand codes that must be serviced. Certain codes, such as those for the wheel speed sensors and the pump motor, only set while the vehicle is being driven.

**To clear the codes:**

1. Select **Clear Codes**.
A “key on” verification screen displays. Make sure the ignition is switched on.
2. Select to continue.
The self-test initiated screen displays.
3. When the test finishes a codes cleared screen displays.

Clearing Code Memory

The scan tool retains codes in its memory. The scan tool memory, not vehicle memory, can be cleared using any of the following methods:

- Repeat the test, which overwrites the previous code.
- Select a different system for testing.
- Enter a new vehicle ID.

Review Codes

Return to the service code menu from the KOEO self-test or memory code test and Review Codes displays as a selection. When this selection is available, it indicates recorded codes are in scan tool memory from either, or both tests

**To review codes:**

1. Select **Review Codes**.
A code list, similar to the lists displayed at the end of the self-tests, displays.
2. Fix the problems in the order listed. Also, remember these important points about the review codes list:
 - Review all codes until “end of list” appears.
 - The scan tool saves codes from the most recent test for display under review codes. On a re-test, codes from the previous test are replaced with a new list.
 - Always write down continuous memory codes after any test.
 - If MEMORY CODES was selected, the scan tool saves the codes in memory, but the Clear Codes selection must be used to clear the ABS module memory.

Print Codes

This selection is available on the Service Code menu following either a KOEO self-test or a memory code test. All printouts of the code list include the vehicle ID.

**To print the service code list from memory:**

1. Connect the scan tool to a compatible printer.
2. Select **Print Codes**.

ABS Data Communication Guidelines



NOTE:

ABS functions are disabled during data communication. If the vehicle is driven, ABS will not function. The ABS lamp may flash rapidly during data transmission.

Follow these steps to enter and exit ABS data:

1. Verify that the ignition is off when entering the vehicle ID.
2. Turn the ignition on.
3. Select Data Display.
4. Turn the ignition off after completing ABS data tests.

12.3 Testing Airbag, Transfer Case, and Body Module Systems through the 16 Pin Connector

For applicable 1996–2008 models, Airbag, Body Module, or Transfer Case systems may be selected. In Body Modules, the applicable modules may be selected, including:

- Body Control Module (BCM)
- Electronic Automatic Temperature Control (EATC)
- Electronic Power Steering (EPS)
- Generic Electronic Module (GEM)
- Instrument Cluster Module (ICM)
- Parking Aid Module (PAM)
- Passenger Junction Box (PJB)
- Tire Pressure Module (TPM)

The Codes Menu selection from the Main Menu for the specific system offers the choices available for the test vehicle.

The Data Display selection is available on most 1996 and later vehicles. It operates similarly to Data (No Codes) for engine testing.

This chapter contains information for testing Mitsubishi vehicles with the Asian Import Vehicle Communication Software (VCS). The following Mitsubishi systems may be available for testing:

- Engine
- Transmission
- Antilock Brake System (ABS)
- Airbag (SRS)

13.1 Testing Engine, Transmission, ABS, and SRS

Mitsubishi engine, transmission, and SRS (airbag) testing includes:

- “Code Reading Connectors and Locations” on page 117
- “Transmission Manual Code Reading” on page 121
- “ABS Manual Code Reading” on page 121
- “Codes and Data (Slow)” on page 122
- “Clearing Codes” on page 122
- “Actuator Tests” on page 122

13.1.1 Code Reading Connectors and Locations

Refer to Figure 13-1 and Table 13-1 on page 118 for diagnostic connector locations.

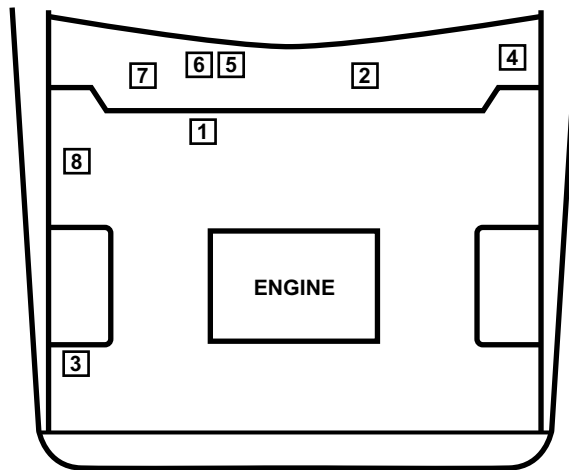

Figure 13-1 Common connector locations

Table 13-1 Common connector locations

VEHICLE	YEAR		LOCATION
3000 GT	1991-93	4	Next to fuse panel
	1994-99	2	Next to console
Cordia/Tredia	1984-88	8	Near firewall
Diamante	1992-96	4	Next to fuse panel
	1997-04	2	Next to console
Eclipse	1990-94	4	Next to fuse panel
	1995-05	2	Next to console
Endeavor	2004-05	2	Next to console
Expo/LRV	1992-96	4	Next to fuse panel
Galant	1985-87	6	Next to glovebox striker
	1989-93	4	Next to fuse panel
	1994-05	2	Next to console
Lancer	2002-05	2	Next to console
Lancer Sport Back	2004	2	Next to console
Mirage	1989-96	4	Next to fuse panel
	1997-2002	2	Next to console
Mirage Turbo	1985-88	1	Near firewall
Montero	1989	7	Behind glovebox
	1990-91	5	Next to ECM
	1992-2000	4	Near hood release
	2001-05	2	Next to console
Montero Sport	1997-2004	4	Near hood release
Outlander	2003-05	2	Next to console
Precis	1990-94	4	In fusebox
Sigma	1988-90	6	Next to glovebox striker
Starion	1984-86	3	In engine compartment
	1987-89	6	Next to glovebox striker
Truck	1990-96	4	Next to fuse panel
Van/Wagon	1987-90	4	Next to fuse panel

Connecting to 1987 and Earlier Vehicles



To read codes from most 1987 and earlier vehicles:

- All models use the MULTI-1 adapter to connect the scan tool to the vehicle.
- Use Figure 13-2 to locate and connect to the diagnostic connector for most 1987 and earlier models.

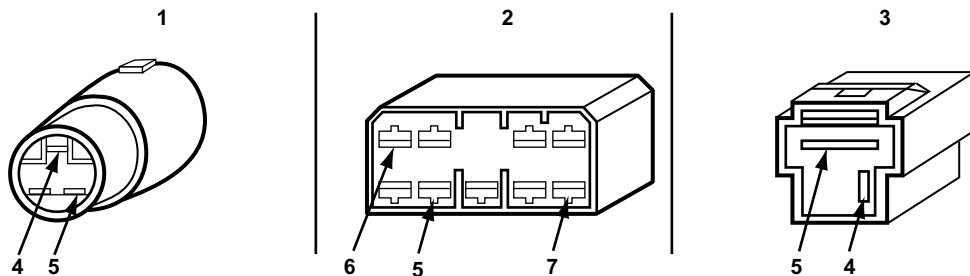

1— 3-pin connector—located on the inner right front fender

2— 9-pin connector—located in glovebox, next to the latch

3— 2-pin connector—located under the dash or in engine compartment

4— Green (preferable) or Yellow

5— Black

6— Engine: Green (preferable) or Yellow

7— Transmission: Green or Yellow

Figure 13-2 Diagnostic connectors for most 1987 and earlier vehicles

Connecting to 1988 and Later OBD-I Vehicles



To read engine and transmission codes from most 1988 and later OBD-I vehicles:

- Use the HYUN-2 adapter (Figure 13-3).

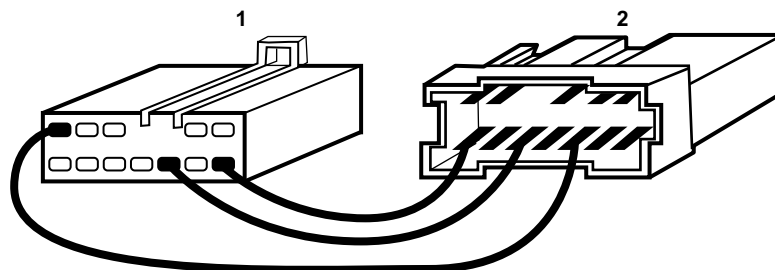

1— HYUN-2 adapter

2— Connector

Figure 13-3 Connector and adapter for SRS system on most 1994 and earlier vehicles

Connecting to OBD-II Vehicles



To read codes from OBD-II vehicles with 12 and 16-pin connectors:

- Use the MITSU-1 adapter with the OBD-II adapter attached (Figure 13-4 on page 120).

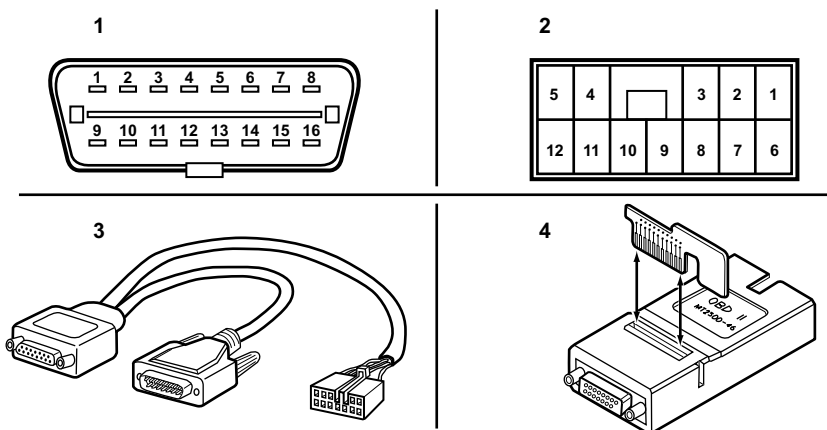

- 1— 16 pin connector
- 2— 12-pin connector
- 3— Mitsu-1 adapter
- 4— OBD-II adapter

Figure 13-4 connectors and adapters for most OBD-II vehicles



NOTE:

Most OBD-II vehicles have 16-pin and 12-pin connectors and use the MITSU-1 adapter connected through the OBD-II adapter. The MITSU-1 lead with the 12-pin connector is not connected on all vehicles. Follow instructions on the scan tool for correct hookup.

13.1.2 Supplemental Restraint System (SRS) Code Reading



To read SRS codes from most 1994 and earlier vehicles:

- Use the HYUN-2 adapter and red terminal converters (Figure 13-5)

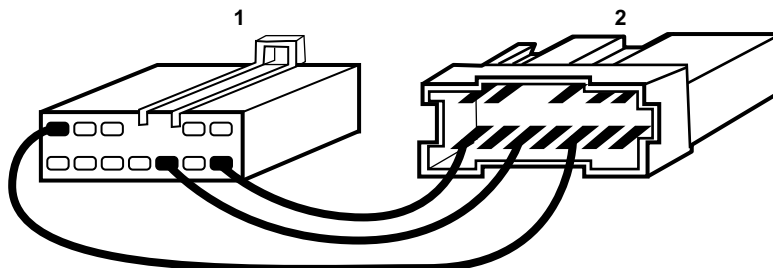

- 1— HYUN-2 adapter
- 2— 12-pin connector

Figure 13-5 Connector and adapter for most 1994 and earlier SRS

13.1.3 Transmission Manual Code Reading

Mitsubishi models transmit Type 11 manual transmission codes, see Figure 13-6 and Table 13-2.

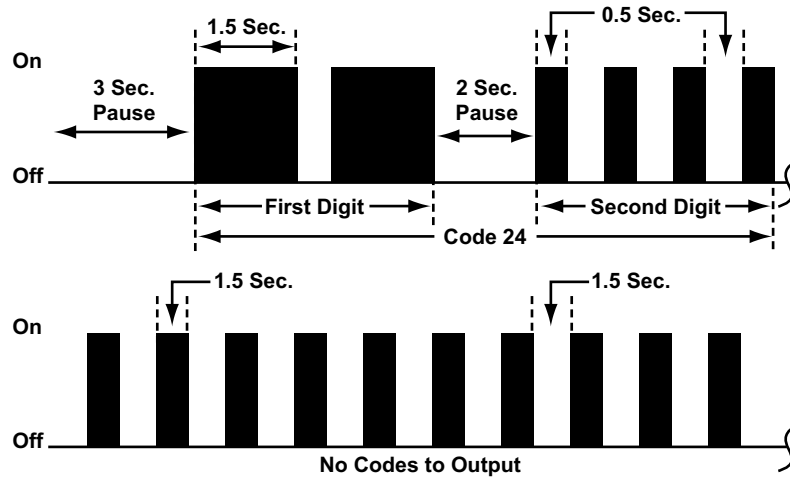

Figure 13-6 Mitsubishi transmission Code Type 11

Table 13-2 Mitsubishi transmission Code Type 11

Pattern:	For code output: long and short For no code output: repeating straight count
Read codes on:	A/T oil temp lamp or neutral indicator lamp
Start codes by:	16-pin OBD-II data link connector: jump pin 1 to ground.
When done:	Remove the jumper wire and clear codes.
Code display cycle repeats as long as system is in a diagnostic state.	

13.1.4 ABS Manual Code Reading

Mitsubishi models transmit Type 11 ABS codes, see Figure 13-7 below and Table 13-3.

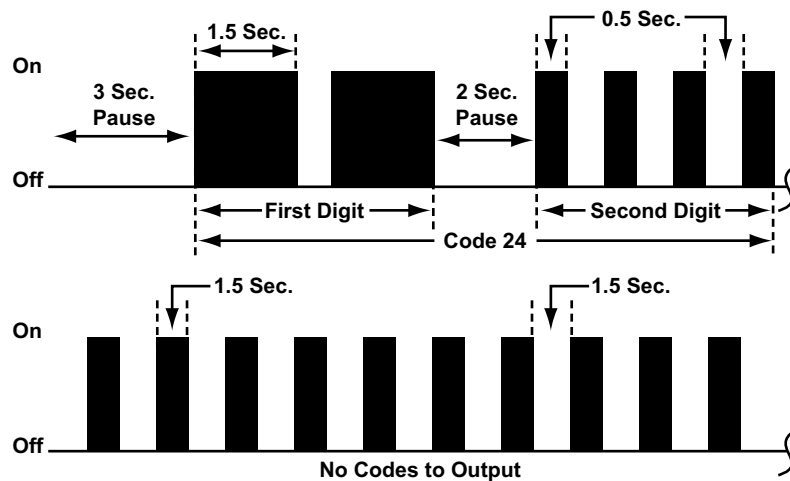

Figure 13-7 Mitsubishi ABS Code Type 11

Table 13-3 *Mitsubishi ABS Code Type 11*

Pattern:	For code output: long and short For no code output: repeating straight count
Read codes on:	ABS warning lamp
Start codes by:	16-pin OBD-II DLC: jump pin 1 to ground; or connect an analog meter across pins 4 or 5 to pin 8. 12-pin diagnostic connector: connect an analog meter across pins 4 and 12.
When done:	Remove the jumper wire and clear codes.
Code display cycle repeats as long as system is in a diagnostic state. A battery surge that causes the ABS system to fail may cause Code 16 to set.	

13.1.5 Codes and Data (Slow)

Some 1988 and later models with the 3.0L SOHC V6 engine transmit data at a 63 baud rate. The Main Menu for these vehicles displays a Codes and Data (Slow) option.

13.1.6 Clearing Codes

Most 1988 and later Mitsubishi models let you clear trouble codes from PCM memory through the scan tool. Select Clear ECM Codes from the Scanner menu.

When codes are cleared, the scan tool returns to the previous test mode, and “No Codes Present” displays to indicate that codes are cleared.

If code clearing fails for any reason, the previous codes reappear at the top of the data list. If this happens, repeat the code clearing procedure.

13.1.7 Actuator Tests

Most pre-OBD-II and all 2002–03 OBD-II models have the Actuator Tests selection on the Main Menu. All actuator tests, except injector and timing tests are key-on, engine-off (KOEO) tests.

A list of available tests displays when Actuator Tests is selected from the menu. The available tests vary by year and model.

During testing, monitor the selected actuator with a multimeter or by listening for actuator activation. A completed test does not mean that the actuator was activated. The scan tool only monitors the engine control module (ECM) commands to the actuator.

When you select an actuator test:

- The scan tool commands the ECM to activate the selected actuator.
- Approximately 5 seconds later, the ECM deactivates the actuator.

All actuator tests except for injector tests must be performed with the key on and engine off (KOEO). Select a KOEO test with the engine running and a test rejected screen displays.

Injector Tests (Engine Running Only)

Injector tests are available from the actuator test menu on most pre-OBD-II vehicles. These tests are performed with the key on and engine running (KOER). The number of injector tests available varies, a 4-cylinder MPI system has four tests; a six cylinder system has six.

When you select an injector test:

- The scan tool commands the ECM to disable the selected injector.
- Approximately 5 seconds later, the ECM reactivates the injector.

This chapter contains information for testing Nissan and Infiniti vehicles with the Asian Import Vehicle Communication Software (VCS). The following Nissan and Infiniti systems may be available for testing:

- Engine
- Transmission
- Antilock Brake Systems (ABS)
- Supplemental Restraint System (SRS)
- Controller Area Network Systems (CAN)

14.1 Testing Engine Systems

Nissan and Infiniti engine system testing includes:

- “Code Reading Connectors and Locations” on page 124
- “Code Types 07” on page 125
- “Functional Tests” on page 129

14.1.1 Code Reading Connectors and Locations

Figure 14-1 and Figure 14-2 on page 125 show Nissan and Infiniti diagnostic connector locations and adapter information for reading engine codes.



To read codes:

1. Connect the molded adapter to the connector shown in Figure 14-1 and Figure 14-2 on page 125, which may be in the following locations:
 - Driver-side kick panel
 - Passenger-side kick panel
 - Left side of dash
 - Under passenger seat
 - Behind driver-side trim panel
2. The scan tool will indicate the connector location.
3. Select “codes” from the “codes and data” menu or select “how to get codes” from the code functions menu and follow the on-screen instructions.

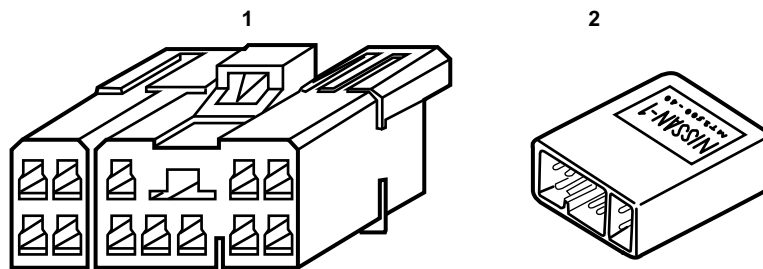

- 1— Diagnostic connector
- 2— NISSAN-1 adapter

Figure 14-1 Vehicle diagnostic connector



NOTE:

Some models have a similar-looking 16-terminal connector under the instrument panel that is not a scan tool connector.

Pre-1995 vehicles that do not have this 12-pin diagnostic connector may have an ECM with one or two fault-indicating LEDs. Refer to “Code Types 07” for information on reading codes from these vehicles.

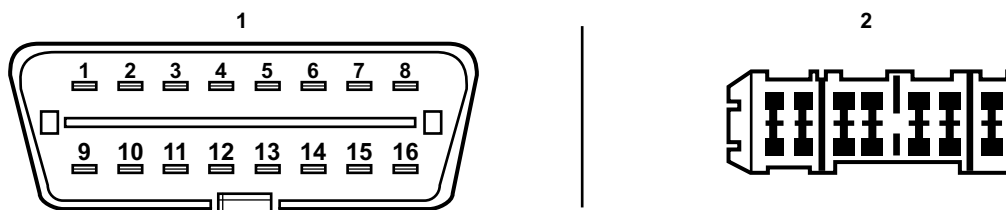

- 1— 16-pin DLC
Use OBD-II adapter.
- 2— 14-pin connector
Use the NISSAN-2 adapter.

Figure 14-2 Nissan diagnostic connectors

14.1.2 Code Types 07



NOTE:

For transmission codes on models with the 4EAT transmission, see “Testing Transmission Systems” on page 132.

If the test vehicle has a diagnostic connector for code gathering, the scan tool displays vehicle connection instructions at the end of the vehicle ID sequence (See “To read codes:” on page 124.

If the vehicle does not have a diagnostic connector for code gathering, select How To Get Codes from the Code Functions menu and manual code gathering instructions display (see “How to Get Codes” on page 15). You can also gather codes manually on some vehicles with a diagnostic connector.

The scan tool displays the control system name and code type. Nissan uses three basic types of control system:

- Two mode system that outputs Code Type 07a
- Five mode system that outputs Code Type 07a
- Two mode system that outputs Code Type 07b

Both code types flash 2-digit (10s and 1s) codes.

Code Type 07a—Two Mode System

On models that use Code Type 07a (two mode system), the ECM is placed in the diagnostic mode by activating a rotary or slide switch on the ECM as follows (Figure 14-3):

Table 14-1 Rotary and slide switch functions

SWITCH	MODE
Rotary Switch	Clockwise = diagnostic mode
	Counterclockwise = normal vehicle operation
Slide Switch	On = diagnostic mode
	Off = normal vehicle operation

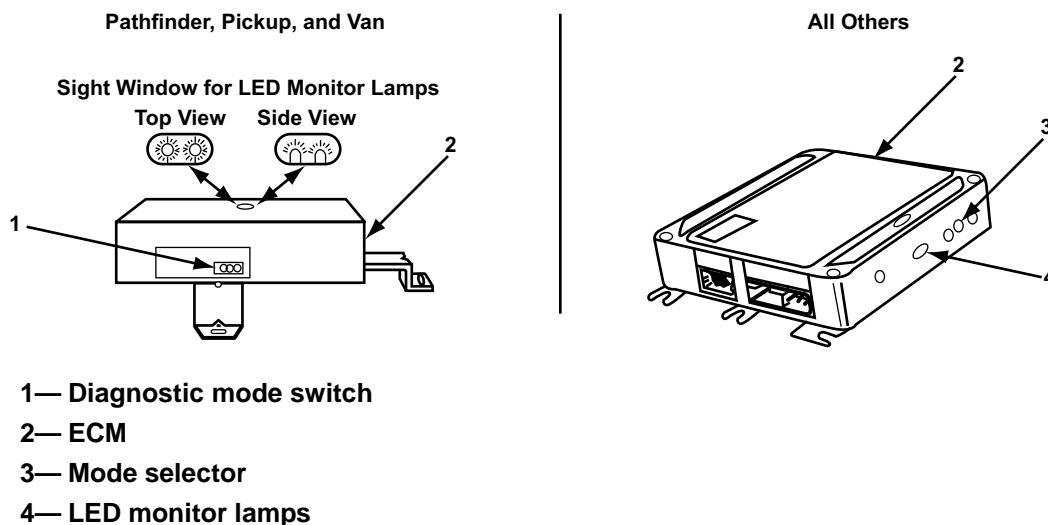

Figure 14-3 ECM switch locations

With the diagnostic switch in the “normal vehicle operation” position, the LEDs can be used to check oxygen sensor operation and air-fuel ratio control. Refer to Nissan service procedures.

When the ECM is first placed in the diagnostic mode, the LEDs flash several codes. These codes indicate that the ECM has not yet received input signals from several switches. The codes may be valid or false. For accurate diagnosis, verify the code status by operating the appropriate switches to send input signals to the ECM.

**To read codes for two-mode control systems with Code Type 07a:**

1. Verify that the diagnostic switch is in the normal vehicle operation position: slide the switch to the OFF position and the rotary switch fully counterclockwise.
2. Turn the ignition on.
3. Verify that the LEDs light for a bulb check.
If the LEDs do not light, refer to Nissan test procedures for diagnosis. Codes cannot be displayed if the LEDs do not light for a bulb check.
4. Turn the rotary diagnostic switch fully clockwise or move the slide switch to ON.
5. Observe the LEDs.
At this point, the LEDs flash several codes for switch inputs or other signals that the ECM has not received. These may include codes 23, 24, and 31 or others. Operate switches as explained in steps 6 and 7 to verify code status.
6. For most models:
 - a. Depress and release the accelerator.
 - b. Move the gear selector from neutral through the drive ranges and back to neutral (automatic transmission), or from neutral to the highest gear position and back to neutral (manual transmission).
 - c. Turn the air conditioner switch or heater blower switch from OFF to ON to OFF.
 - d. Proceed to step 8.
7. For 1985–89 300ZX:
 - a. Start the engine.
 - b. With an automatic transmission, apply the service brakes and shift the transmission from neutral to drive and back to neutral.
 - c. For turbo models, drive at a speed above 6 mph.
 - d. For all models, turn the A/C switch or heater blower switch from OFF to ON to OFF with the engine running.
 - e. For models without A/C, turn the headlamp and rear demister switches from OFF to ON to OFF.
8. Observe the LEDs on the ECM for flashing codes.
If no faults are present, the LEDs should flash code 31 for vehicles without A/C or code 44 for vehicles with A/C. Any other codes flashed at this point are valid trouble codes that should be diagnosed.
9. Turn the rotary diagnostic switch fully counterclockwise or move the slide switch to OFF.
10. Turn the ignition off.

Code Type 07a—Five Mode System

Gather codes manually from these systems by placing the ECM in the diagnostic mode and observing two flashing LEDs (Figure 14-4 on page 128). These systems flash the first digit on the red LED (10s digit). The second digit flashes on the green LED (1s digit).

For example: Red–Red–pause–Green–Green–Green indicates code 23.

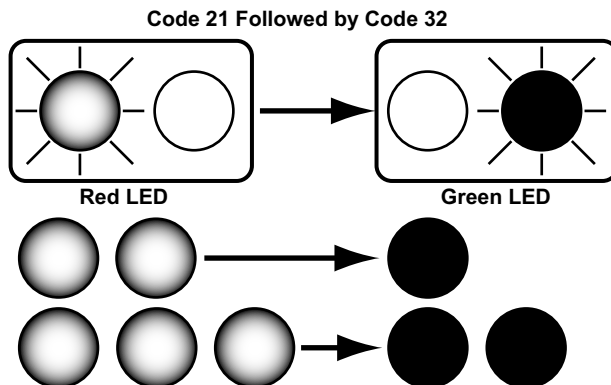

Figure 14-4 Nissan Code Type 07a—five mode system

Table 14-2 Nissan Code Type 07a

Used on:	Nissan (1990 and earlier models)
Pattern:	10s and 1s
Read codes on:	Red LED (10s) and green LED (1s) on ECM
Start codes by:	Follow the appropriate diagnostic code reading procedure.
When done:	Turn the ignition off, turn the diagnostic switch off or counterclockwise, and clear codes.
Code 44 or 55 are pass code (system OK) for models with A/C. Code 31 may be a pass code for models without A/C.	



To read codes for five-mode control systems with Code Type 07a:

1. Locate the ECM below the passenger seat (Table 14-2).
2. Turn the ignition on; do not start the engine.
3. Verify that the LEDs light briefly for a bulb check.
If the LEDs do not light, correct the problem before proceeding.
4. While observing the two LEDs on the ECM, turn the diagnostic selector switch on the ECM fully clockwise.
5. After the LEDs flash three times, turn the diagnostic selector switch on the ECM fully counterclockwise.

IMPORTANT:

Do not allow the LEDs to flash four times with the selector switch fully clockwise or the trouble codes will be erased.

The ECM is now in the diagnostic mode (see Table 14-2).

6. Write down any codes present.
Code 55 is a pass code. All codes flash only once. Repeat steps 3 through 6 to observe any missed codes.
7. Clear codes:
 - a. Turn the diagnostic selector switch on the ECM fully clockwise.
 - b. After the LEDs flash four times, turn the diagnostic selector switch on the ECM fully counterclockwise.
8. Repeat steps 3 through 6 to verify that no more codes are present.

Code Type 07b—Two Mode System

The system that outputs Code Type 07b is also placed in diagnostic mode by activating a switch on the ECM. Codes then simultaneously flash on the check engine lamp and a single LED on the ECM. These models flash codes as a series of long-and-short pulses (10s and 1s) on the LED and on the CHECK engine lamp on the dash (Figure 14-5 and Table 14-3).

For example: Long–Long–Long–pause–Short–Short indicates code 32.

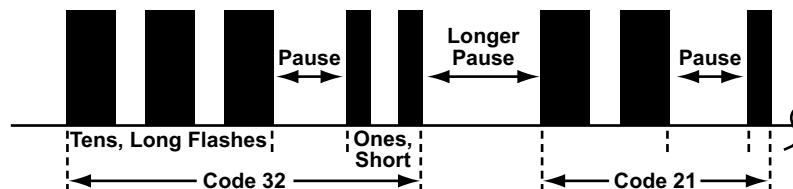

Figure 14-5 Nissan Code Type 07b

Table 14-3 Nissan Code Type 7b

Used on:	Nissan (1990 and later models without a connector for hook-up)
Pattern:	10s and 1s—Long and short
Read codes on:	Check Engine lamp (or LED on ECM)
Start codes by:	Follow the appropriate diagnostic code reading procedure.

This procedure is for vehicles that do not have a connector for hook-up. To display codes, the ECM must be in the diagnostic mode.



To read codes for two-mode control systems with Code Type 07b:

1. Locate the ECM below the glove box on the toe board.
2. Turn the ignition on with the engine off.
3. Verify that the LED and the Check Engine lamp light briefly for a bulb check. If either does not light, correct the problem before proceeding.
4. Turn the diagnostic selector switch on the ECM fully clockwise.
5. Wait at least two seconds.
6. Turn the ECM diagnostic selector switch fully counterclockwise.
7. Count the long-and-short flashes either on the LED in the ECM or on the Check Engine lamp in the dash. Any codes present flash one time each.
For example: Long–Long–Long–pause–Short–Short indicates code 32.
8. Write down any codes present.
9. Clear codes by turning the diagnostic selector switch on the ECM fully clockwise. Wait two seconds then repeat steps 5 and 6 to verify that no more codes are present.
10. Turn the ignition off.

14.1.3 Functional Tests



NOTE:

Operations described in this section are not available on all tool platforms.

The Functional Tests selection is available for most 1987–96 models with electronic concentrated control systems (ECCS).

IMPORTANT:

Read trouble codes before selecting a functional test, otherwise codes may be lost.

There are five diagnostic modes built into vehicles with ECCS:

- Mode 1—Exhaust monitor
- Mode 2—Air/Fuel Check
- Mode 3—Self-Diagnosis
- Mode 4—Switch Test
- Mode 5—Real Time Monitor

A Base Idle Test is also available on the menu. However, this “special” test is not a standard ECCS mode test. The sections that follow describe each of these functional tests.

The self-diagnosis mode (mode 3) is not available on the Functional Tests menu. This mode is entered when you select Auto Code Read from the Code Functions menu.

Once you select a functional test, the scan tool automatically switches the ECM to the correct mode and tells you how to begin the testing. As the ECM changes modes, LEDs 3 and 4 on the scan tool flash the corresponding mode number.

Exhaust Monitor Test (Mode 1)

The Exhaust Monitor test lets you monitor the mixture ratio feedback signal from the oxygen sensor (O2S).

**To perform an Exhaust Monitor test:**

1. Select **Exhaust Monitor** from the Functional Tests menu.
A test initialization screen displays.
2. Start the engine and warm it to normal operating temperature.
3. Select to begin the test.
4. When prompted, raise and hold engine speed at 2000 RPM.
The display shows Lean when the exhaust is lean, and Rich when rich. LED 3 on the scan tool flashes to indicate that the scan tool is receiving a signal from the O2S.

Air/Fuel Check (Mode 2)

The Air/Fuel Check lets you monitor the air-to-fuel ratio by comparing the oxygen sensor (O2S) signal to the fuel injector control signal.

**To perform an Air/Fuel check:**

1. Select **Air/Fuel Check** from the Functional Tests menu.
A test initialization screen displays.
2. Start the engine and warm it to normal operating temperature, then select to continue.

3. As instructed, increase and hold engine speed at 2000 RPM.

The Exhaust parameter displays Lean when the O2S detects a lean exhaust, and Rich when the exhaust is rich. The Compensation parameter displays the response sent to the fuel injection system.

Typically, when the O2S feedback signal (Exhaust) is Lean, the fuel injection system is commanded to go rich, and the Compensation parameter displays Rich.

Similarly, when the O2S feedback signal (Exhaust) is Rich, the fuel injection system is commanded to go lean, and the Compensation parameter displays Lean.

LED 3 on the scan tool flashes as it receives a signal from the O2S, and LED 4 flashes as it receives the signal from the Compensation circuit.

When both readings are the same and the LEDs flash simultaneously, the O2S signal and the fuel injection command are in balance.

Self-Diagnosis (Mode 3)

Nissan mode 3 is the Auto Code Read selection from the Code Functions menu on the scan tool display (see “Automatic Code Reading” on page 10).

Switch Test (Mode 4)

The Switch test lets you check the following on-off switch circuits:

- Vehicle speed sensor (VSS)
- Start signal
- Idle switch



To perform a Switch test:

1. Select **Switch Test** from the Functional Tests menu.
A test initialization screen displays.
2. Start the engine and warm it to normal operating temperature.
3. Select to begin the test.

The VSS parameter displays Above when speed exceeds 12 mph (20 kph), and Below when speed is 12 mph or lower. Also, LED 3 turns on when the vehicle speed is above 12 mph and off when below.

The IGNITION SW OR IDLE SW parameter alternately displays High or Low each time the ignition switch or idle switch status changes. Also, LED 4 turns on when this parameter displays Low and off when High.

Real-Time Monitor (Mode 5)

This function lets you check the following vehicle sensor circuits:

- Airflow meter
- Fuel pump
- Crank angle sensor
- Ignition coil primary

**To perform a Real Time Monitor test:**

1. Select **Real Time Monitor**.
A test initialization screen displays.
2. As instructed, start the engine and press **Y**.
3. Drive the vehicle to fully test these parameters.
If a problem is detected in a sensor circuit, the displayed parameter changes from Normal to Faulty. The LED 3 or 4 flashes, and the scan tool beeps.

Base Idle Test

The Base Idle test lets you check and adjust the vehicle base idle speed.

**To perform a Base Idle test:**

1. Select **Base Idle Test** from the Functional Tests menu.
A test initialization screen displays.
2. Start the engine and warm it to normal operating temperature.
3. Select to begin the test.
4. Follow the on-screen instructions. A countdown timer also displays for your convenience.

**NOTE:**

When the timer reaches 0:00 it does not reset.

5. Select to continue the test.
The scan tool has now instructed the vehicle ECM to close the auxiliary air control (AAC) valve. You can now adjust the vehicle base idle.

Idle Air Volume Relearn

The Idle Air Volume Relearn is an operation that allows the ECM to quickly learn the idle air volume adaptive value after certain system components are replaced.

Once selected, the test runs by itself without any operator input. The test takes about 30 to 60 seconds and a "test completed" message displays at the conclusion of the procedure. If the test complete message does not display, switch the ignition off, verify that all electrical loads are off, start the engine and repeat the test.

14.2 Testing Transmission Systems

Transmission system tests are available on models with the 4EAT transmission.

14.2.1 Nissan 4EAT Transmission Testing

If you select Transmission from the System Selection menu at the end of the vehicle ID sequence, the scan tool gives you instructions for applying power.

Automatic code gathering is not available on older Nissan 4-speed Electronic Automatic Transmissions (4EAT), but is available on most 1990 and later models. For transmission codes, select How To Get Codes from the Code Functions menu and the scan tool either displays manual code gathering instructions or gathers the codes for you.

For 4EAT transmissions that require manual code gathering, Nissan uses Type 7c transmission codes (Figure 14-6 and Table 14-4 on page 133).

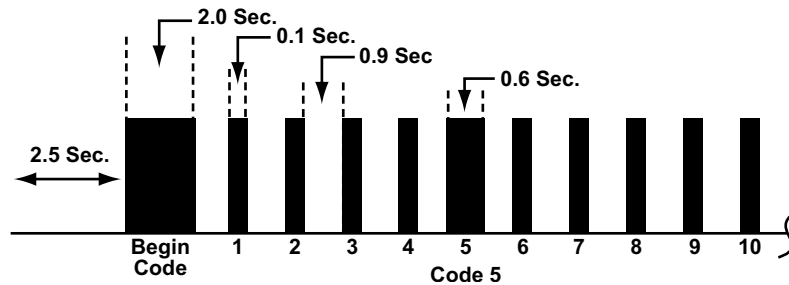

Figure 14-6 Nissan Code Type 07c

Table 14-4 Nissan Code Type 7c

Used on:	Nissan 4EAT transmissions
Pattern:	Long flash
Read codes on:	Power, A/T Check, or O/D lamp (depending on vehicle)
Start codes by:	Follow the appropriate Nissan procedure.
When done:	Codes clear automatically when the problem is fixed.

Code Type 7c consists of a 2-second flash, followed by a 1-second pause, then a series of ten short (0.1-second) flashes. Short flashes represent code numbers 1 through 10. A long (0.6-second) flash indicates a fault at the indicated position.

For example, Short–Short–Short–Short–Long–Short–Short–Short–Short–Short indicates Code 5 because the fifth flash is long. If no codes are present, the ten flashes are all short (0.1-second). The code sequence is followed by a 2.5-second pause, a 2-second flash, then the pattern repeats.

To read Nissan 4EAT transmission codes manually, you must follow a specific diagnostic procedure. Failure to do so may result in misreading codes or inaccurate diagnosis.



To manually place the Nissan 4EAT control system in diagnostic mode:

1. Start and warm the engine to operating temperature.
2. Switch the ignition off, move the gear selector to Park, set the A/T Mode switch (optional) to Auto, and the O/D switch to On.
3. Turn the key on (engine off).
Depending on the vehicle, either the Power lamp, the A/T Check lamp, or the O/D lamp illuminates for approximately 2 seconds. This is the lamp that flashes codes.
4. Turn the ignition off, place the gear selector in Drive, and set the O/D switch to Off.

5. Turn the key on (engine off), wait 2 seconds and move the gear selector to 2nd.
6. Set the O/D switch to On, move the gear selector to 1st, and set the O/D switch to Off.
7. Fully depress and release the throttle to begin gathering manual codes.
The lamp flashes Code Type 7c (Figure 14-6). If no codes are present, the lamp flashes evenly 10 times after a long start flash.

14.3 Testing Antilock Brake Systems (ABS)

Nissan and Infiniti ABS system testing includes:

- “Code Reading Connectors and Locations” on page 134
- “Manual Codes” on page 135
- “Actuator Tests” on page 135

14.3.1 Code Reading Connectors and Locations

Nissan and Infiniti ABS systems use several types of connectors for code reading and functional tests. Most 2000 and later Nissan and Infiniti ABS codes can be read and cleared using the OBD-II connector in Figure 14-8. Other systems require a jumping pins on a test connector.

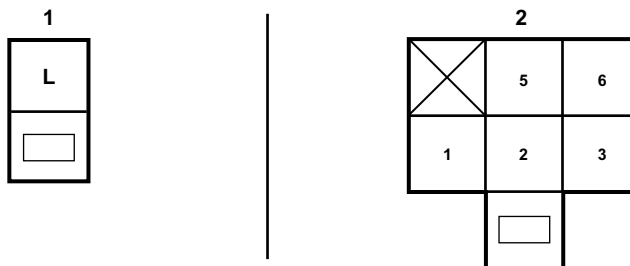

- 1— 1-pin check connector—jumper terminal L to ground
 2— 6-pin check connector—jumper terminal 3 to ground

Figure 14-7 Nissan diagnostic connectors

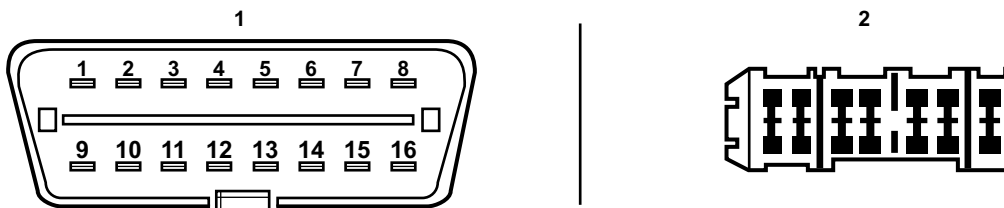

- 1— 16-pin DLC—jumper terminal 9 to ground
 2— 14-pin DLC—jumper terminal 9 to ground

Figure 14-8 Nissan diagnostic connectors

These connectors may be found either under dash near the steering column, or behind the driver-side kick panel.

14.3.2 Manual Codes



To read manual codes:

1. Select **Codes** from the Codes and Data menu, or select **How to get codes** from the Codes Functions menu.
The scan tool will indicate the connector location and connector type. Please refer to section 14.3.1 for more information.
2. Locate the connector and follow the on-screen instructions.
Codes will flash on the ABS warning lamp as a series of long and short pulses (10s and 1s). Multiple codes, if present, will be separated by a long pause.

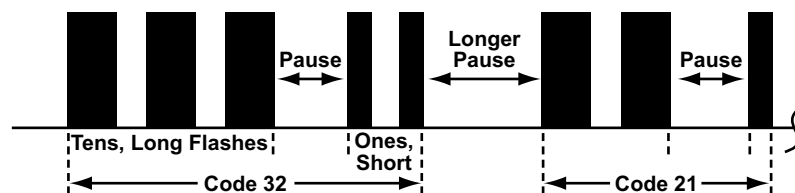

Figure 14-9 Nissan ABS codes

For repair instructions or if no codes flash, refer to the service manual.

14.3.3 Actuator Tests

Nissan and Infiniti ABS actuator tests selection is available for 2000 and later vehicles that require the use of the K-2A key.



NOTE:

Not all platforms may support tests.



To activate an actuator test:

1. Select **Actuator Tests** from the main menu.
2. Select the test you wish to activate, and follow the on-screen instructions, if any.

14.4 Testing Supplemental Restraint Systems (SRS)

Most 2000 and later Nissan and Infiniti SRS, or airbag, codes can be read and cleared using the scan tool. Manual codes are available on other models.

14.4.1 Manual Code Reading

Nissan and Infiniti vehicles transmit Type 07b SRS codes (Figure 14-10 and Table 14-5 on page 136).

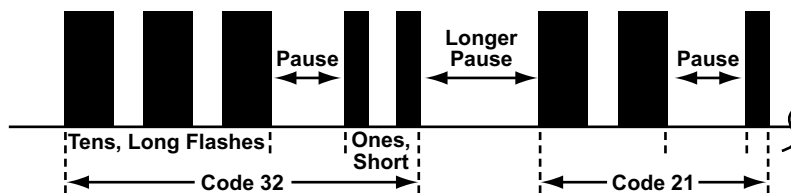

Figure 14-10 Nissan Code Type 07b

Table 14-5 Nissan Code Type 7b

Used on:	Nissan (most 1990 and later models)
Pattern:	10s and 1s—Long and short
Read codes on:	Check Engine lamp (or LED on ECM)
Start codes by:	Follow the appropriate diagnostic code reading procedure.

2000 and Earlier Vehicles



NOTE:

Diagnosis mode activates only when a malfunction is detected.



To read SRS codes for 2000 and earlier vehicles:

1. Turn the ignition on.
2. Press the driver-side door switch at least 5 times within 7 seconds.



To clear codes for 2000 and earlier vehicles:

1. Repair the malfunction.
2. Switch the ignition off for at least 1 second, then switch it back on.

2001 Vehicles



NOTE:

If SRS does not enter diagnosis mode even though malfunction is detected in user mode, check the vehicle battery voltage. If the battery voltage is less than 9 V, charge the battery.



To read SRS codes for 2001 vehicles:

1. Turn ignition switch on.
2. After the Airbag warning lamp lights for 7 seconds, turn ignition switch off within 1 second.
3. Wait more than 3 seconds.
4. Repeat the previous steps 1 to 3 times.
5. Turn ignition switch on.
SRS is now in diagnosis mode.



To clear codes for 2001 vehicles:

1. Open driver-side door.
2. Turn ignition switch on.

14.5 Testing Body Control Module (BCM) Systems

The BCM monitors various electrical components, such as door locks, windshield wipers, keyless entry, Intelligent Key, headlamps, and accessories, located on the body interior and exterior. Codes and data are available from BCM, and are accessed through the DLC.

14.6 Testing Controller Area Network (CAN) Systems

The CAN is a multiplex communication system that transfers data between the various electronic control modules (ECMs) on the vehicle. Two data lines, CAN-H and CAN-L, connect the ECMs together to form the main line of the network. A termination circuit is used for the ECM on either end of the CAN network, additional ECMs are on branch lines that splice into the main lines. Twisted-pair data line style is used to reduce interference on the circuits.

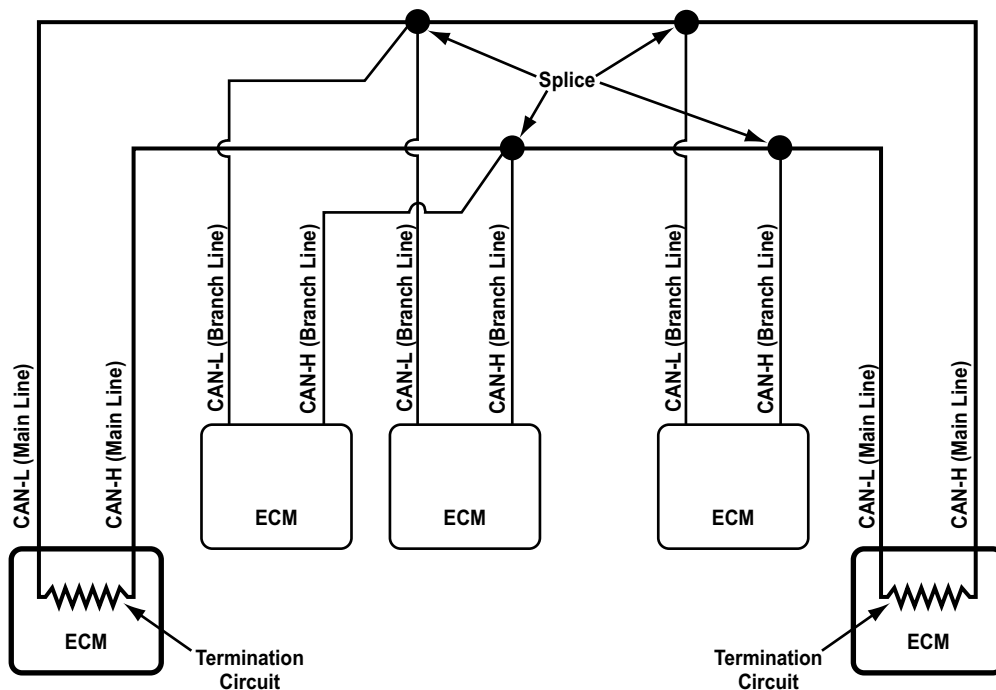

Figure 14-11 Sample CAN schematic

Based on the current applied, the termination circuit produces an electrical potential difference between the data lines. This potential difference is what the ECMs on the CAN system use to transmit and receive data.

Refer to the vehicle equipment identification decal on the vehicle to determine which type of CAN system is used on the test vehicle. Also verify that the specified equipment is actually installed on the vehicle.

A specific ECM either transmits a signal to or receives a signal from the CAN network for each data parameter. Use the following tables to determine if a signal is transmitted or received by an ECM.

Table 14-6 Acronym and abbreviation identification

Item	Description
ABS	Antilock brake, traction control, and/or vehicle dynamic control module
BCM	Body control module
DLC	Data link connector
ECM	Engine control module
IPDM-E	Intelligent power distribution module-engine room
M&A	Unified meter and A/C amplifier module
R	Receives signal from the CAN network
STRG	Steering angle sensor module
T	Transmits signal to the CAN network
TCM	Transmission control module

Table 14-7 CAN Type 1 communication signal identification (part 1 of 2)

Signal	Control Unit				
	ECM	BCM	M&A	ABS	IPDM-E
A/C Compressor feedback	T		R		
A/C Compressor request	T				R
Accelerator pedal position	T			R	
ASCD CRUISE lamp	T		R		
ASCD SET lamp	T		R		
Cooling fan speed request	T				R
Engine coolant temperature	T		R		
Engine speed	T		R	R	
Fuel consumption monitor	T		R		
Malfunction indicator lamp	T		R		
A/C switch	R	T			
Blower fan motor switch	R	T			
Buzzer output		T	R		
Day time running light request		T			R
Door switch		T	R		R
Front wiper request		T			R
High beam request		T	R		R
Horn chirp		T			R

Table 14-7 CAN Type 1 communication signal identification (part 2 of 2)

Signal	Control Unit				
	ECM	BCM	M&A	ABS	IPDM-E
Ignition switch		T			R
Low beam request		T			R
Position lights request		T	R		R
Rear window defogger switch		T			R
Sleep request 1		T	R		
Sleep request 2		T			R
Theft warning horn request		T			R
Tire pressure		T	R		
Turn indicator		T	R		
Wake up request 1		T	R		
Fuel level sensor	R		T		
Seat belt buckle switch		R	T		
Vehicle speed sensor	R	R	T		
			R	T	
ABS warning lamp			R	T	
Brake warning lamp			R	T	
Front wiper stop position		R			T
High beam status	R				T
Hood switch		R			T
Low beam status	R				T
Rear window defogger control switch	R				T

Table 14-8 CAN Type 2 and 3 communication signal identification (part 1 of 3)

Signal	Control Unit					
	ECM	TCM	BCM	M&A	ABS	IPDM-E
A/C Compressor feedback	T			R		
A/C Compressor request	T					R
Accelerator pedal position	T	R			R	
ASCD CRUISE lamp	T			R		
ASCD OD cancel request	T	R				
ASCD operation	T	R				
ASCD SET lamp	T			R		
Battery voltage	T	R				
Closed throttle position	T	R				
Cooling fan speed request	T					
Engine coolant temperature	T					R
Engine speed	T	R		R	R	
Fuel consumption monitor	T			R		

Table 14-8 CAN Type 2 and 3 communication signal identification (part 2 of 3)

Signal	Control Unit					
	ECM	TCM	BCM	M&A	ABS	IPDM-E
Malfunction indicator lamp	T			R		
Wide open throttle position	T	R				
A/T CHECK indicator lamp		T		R		
A/T position indicator		T		R	R	
A/T self-diagnosis	R	T				
Manual mode gear position		T		R		
Manual mode indicator		T		R		
Output shaft speed	R	T				
Turbine speed	R	T				
A/C switch	R		T			
Blower fan motor switch	R		T			
Buzzer output			T	R		
Day time running light request			T			R
Door switch			T	R		R
Front wiper request			T			R
High beam request			T	R		R
Horn chirp			T			R
Ignition switch			T			R
Low beam request			T			R
Position lights request			T	R		R
Rear window defogger switch			T			R
Sleep request 1			T	R		
Sleep request 2			T			R
Theft warning horn request			T			R
Tire pressure			T	R		
Turn indicator			T	R		
Wake up request 1			T	R		
Fuel level sensor	R			T		
Manual mode shift down		R		T		
Manual mode shift up		R		T		
Manual mode		R		T		
Not manual mode		R		T		
Seat belt buckle switch			R	T		
Stop lamp switch		R		T		
Vehicle speed sensor	R	R	R	T		
				R	T	
A/T shift schedule change demand		R			T	
ABS operation		R			T	
ABS warning lamp				R	T	

Table 14-8 CAN Type 2 and 3 communication signal identification (part 3 of 3)

Signal	Control Unit					
	ECM	TCM	BCM	M&A	ABS	IPDM-E
Brake warning lamp				R	T	
SLIP indicator lamp				R	T	
TSC OFF indicator lamp				R	T	
Front wiper stop position			R			T
High beam status	R					T
Hood switch			R			T
Low beam status	R					T
Rear window defogger control switch	R					T

Table 14-9 CAN Type 4 and 5 communication signal identification (part 1 of 2)

Signal	Control Unit						
	ECM	ABS	TCM	BCM	M&A	STRG	IPDM-E
A/C Compressor feedback	T				R		
A/C Compressor request	T						R
Accelerator pedal position	T	R	R				
ASCD CRUISE lamp	T				R		
ASCD OD cancel request	T		R				
ASCD operation	T		R				
ASCD SET lamp	T				R		
Battery voltage	T		R				
Closed throttle position	T		R				
Cooling fan speed request	T						R
Engine coolant temperature	T				R		
Engine speed	T	R	R		R		
Fuel consumption monitor	T				R		
Malfunction indicator lamp	T				R		
Wide open throttle position	T		R				
A/T shift schedule change demand		T	R				
ABS operation		T	R				
ABS warning lamp		T			R		
Brake warning lamp		T			R		
SLIP indicator lamp		T			R		
VCD OFF indicator lamp		T			R		
Vehicle speed sensor	R		R	R	T		
A/T CHECK indicator lamp			T		R		
A/T position indicator		R	T		R		

Table 14-9 CAN Type 4 and 5 communication signal identification (part 2 of 2)

Signal	Control Unit						
	ECM	ABS	TCM	BCM	M&A	STRG	IPDM-E
A/T self-diagnosis	R		T				
Manual mode gear position			T		R		
Manual mode indicator			T		R		
Output shaft speed	R		T				
Turbine speed	R		T				
A/C switch	R			T			
Blower fan motor switch	R			T			
Buzzer output				T	R		
Day time running light request				T			R
Door switch				T	R		R
Front wiper request				T			R
High beam request				T	R		R
Horn chirp				T			R
Ignition switch				T			R
Low beam request				T			R
Position lights request				T	R		R
Rear window defogger switch				T			R
Sleep request 1				T	R		
Sleep request 2				T			R
Theft warning horn request				T			R
Tire pressure				T	R		
Turn indicator				T	R		
Wake up request 1				T	R		
Fuel level sensor	R				T		
Manual mode shift down			R		T		
Manual mode shift up			R		T		
Manual mode			R		T		
Not manual mode			R		T		
Seat belt buckle switch				R	T		
Stop lamp switch			R		T		
Steering angle sensor		R				T	
Front wiper stop position				R			T
High beam status	R						T
Hood switch				R			T
Low beam status	R						T
Rear window defogger control switch	R						T

This chapter contains information for testing Subaru vehicles with the Asian Import Vehicle Communication Software (VCS). The following Subaru systems may be available for testing or troubleshooting:

- Engine
- Transmission
- Antilock Brake System (ABS)
- Airbag (SRS - Supplemental Restraint System)

15.1 Testing Engine Systems

The following sections include information for testing Subaru engine systems. Subaru engine testing includes:

- “Code Reading Connector Locations” on page 143
- “Connecting the Scan Tool to the Vehicle”
- “Reading Engine Codes” on page 150
- “D-Check and Read Memory Connector Locations”
- “Automatic Code Reading” on page 172
- “Code Type 08” on page 176

15.1.1 Code Reading Connector Locations

This section contains locations for diagnostic connectors for the following Subaru vehicles:

- “Carbureted engine common connector locations” on page 144 (Table 15-1, Figure 15-1)
- “1983–84 Turbo common connector locations” on page 144 (Table 15-2, Figure 15-2)
- “Justy common connector locations” on page 145 (Table 15-3, Figure 15-3)
- “Loyale common connector locations” on page 145 (Table 15-4, Figure 15-4)
- “1990–94 Legacy and 1993–95 Impreza 1.8L common connector locations” on page 146 (Table 15-5, Figure 15-5)
- “SVX common connector locations” on page 147 (Table 15-6, Figure 15-6)
- “XT and XT6 common connector locations” on page 147 (Table 15-7, Figure 15-7)
- “1995 Legacy, 1995 Impreza 2.2L and 1996-06 Subaru common connector locations” on page 148 (Table 15-8, Figure 15-8)

See also “D-Check and Read Memory Connector Locations” on page 166

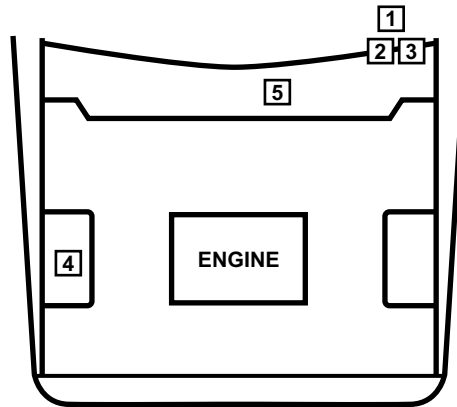

Figure 15-1 Carbureted engine common connector locations

Table 15-1 Carbureted engine connector locations

CONNECTOR	LOCATION
D-Check connectors	1 (next to ECM)
Check connectors 2 and 3	2 (next to ECM)
Check connector 4	3 (next to ECM)
Check connector 1	4 (R/F strut area)
ECM	5 (under steering column)

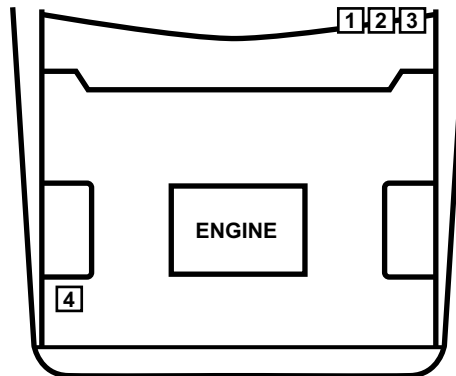

Figure 15-2 1983-84 Turbo common connector locations

Table 15-2 1983-84 Turbo connector locations

CONNECTOR	LOCATION
ECM	1 (under steering column)
D-Check connectors	2 (next to ECM)
Check connectors 1, 2, and 3	3 (next to ECM)
Check connector 4	4 (front of R/F strut tower)

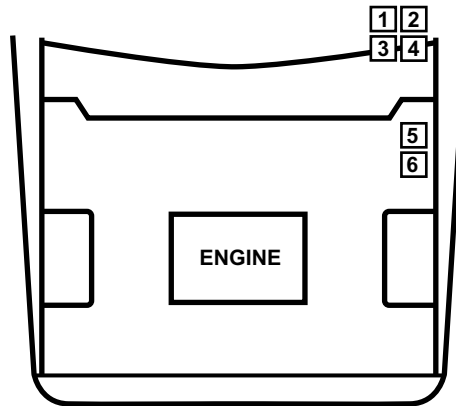

Figure 15-3 Justy common connector locations

Table 15-3 Justy connector locations

CONNECTOR	LOCATION
ECVT D-Check and Read Memory connectors	1 (by ECVT module)
ECM D-Check and Read Memory connectors	2 (by ECM module)
ECVT control module	3 (left of ECM)
ECM control module	4 (left of steering column)
9-pin diagnostic connector	5 (left of fire wall area)
6-pin and 9-pin diagnostic connectors	6 (left of fire wall area)

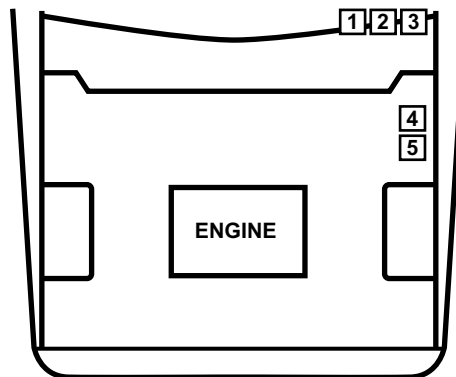

Figure 15-4 Loyale common connector locations

Table 15-4 Loyale connector locations* (part 1 of 2)

CONNECTOR	LOCATION
ECM	1 (under steering column)
D-Check & Read Memory connectors— carbureted, some MPFI and SPI	2 (next to ECM connector)
17-pin or 13-pin Check connector	3 (next to ECM connector)
*Transmission control module (TCM) is located inside the left quarter panel (4EAT only).	

Table 15-4 Loyale connector locations* (part 2 of 2)

CONNECTOR	LOCATION
17-pin or 13-pin Check connector (alternate location) & D-Check connectors	4 (left side of fire wall area)
9-pin Check connector (some models)	5 (left side of fire wall area)
*Transmission control module (TCM) is located inside the left quarter panel (4EAT only).	

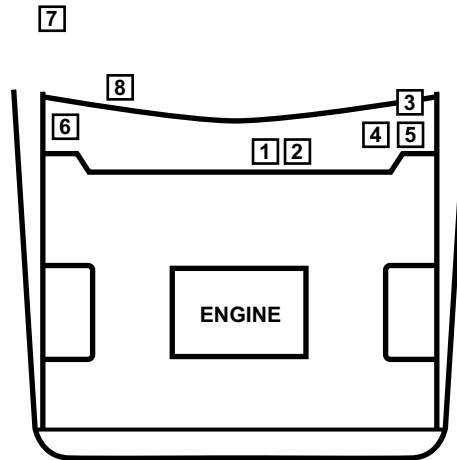
**Figure 15-5** 1990–94 Legacy and 1993–95 Impreza 1.8L common connector locations**Table 15-5** Legacy and Impreza 1.8L connector locations

VEHICLE	YEAR	CONNECTOR	LOCATION
Impreza 1.8L	1993–94	ECM	5 (left side of steering column)
	1993–95	22-pin	1 (left side of heater box)
		9-pin	2 (left side of heater box)
		D-Check and Read Memory for engine and transmission	3 (under left side of dash)
		TCM	4 (left side of steering column)
		ABS controller	7 (under R/F seat carpet)
	1995	ECM	8 (under right side of passenger carpet)
Legacy	1990–94	22-pin	2 (left side of heater box)
		D-Check and Read Memory for engine and transmission	3 (under left side of dash)
		TCM	4 (left side of steering column)
		ECM	5 (left side of steering column)
		9-pin	2 (left side of heater box)
		ABS controller	7 (under R/F seat carpet)

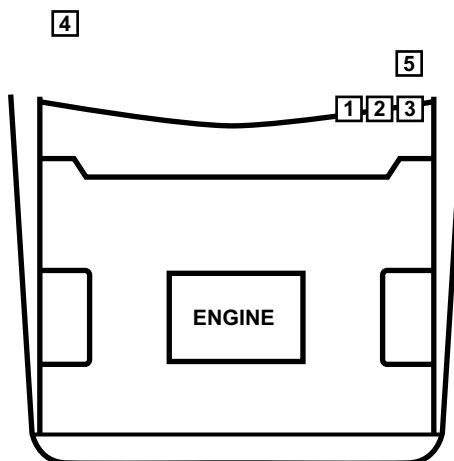

Figure 15-6 SVX common connector locations

Table 15-6 SVX connector locations

CONNECTOR	LOCATION
TCM	1 (under left side of dash)
ECM	2 (under left side of dash)
10-pin and 20-pin connectors	3 (left side of kickpanel)
ABS control unit	4 (under RF seat)
9-pin Check connector and diagnostic connector	5 (left side of kick panel)

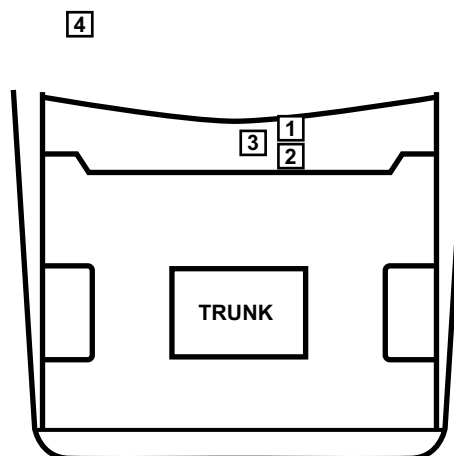

Figure 15-7 XT and XT6 common connector locations

Table 15-7 XT and XT6 connector locations

CONNECTOR	LOCATION
D-Check connector; 9-pin Check connector	1
Read Memory connector	2 (by ECM)
MPFI controller	3 (in trunk below rear window)
TCM and power steering controller connector (under left rear quarter-window)	4

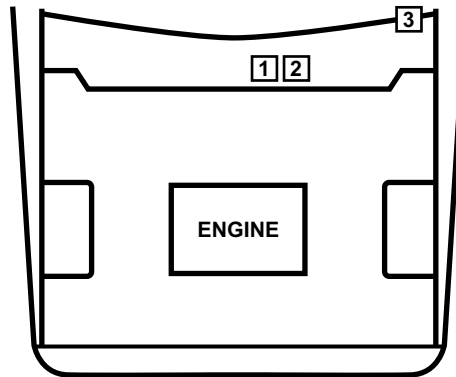

Figure 15-8 1995 Legacy, 1995 Impreza 2.2L and 1996-06 Subaru common connector locations

Table 15-8 1995 Legacy, Impreza 2.2L and 1996 to 2006 connector location

VEHICLE	YEAR	CONNECTOR	LOCATION
Legacy and Impreza 2.2L	1995	ABS diagnosis connector	1 (left side of heater box)
		16-pin OBD-II connector for engine and transmission	2 (under left side of dash)
		Airbag (SRS) diagnosis connector	3 (under left side of dash)
All Models	1996-04	ABS diagnosis connector	1 (left side of heater box)
		16-pin OBD-II connector for engine and transmission	2 (under left side of dash)
		Airbag (SRS) diagnosis connector	3 (under left side of dash)
All except Legacy	2005-06	16-pin OBD-II connector for engine, transmission and ABS	2 (under left side of dash)
		Airbag (SRS) diagnosis connector	3 (under left side of dash)
Legacy		16-pin OBD-II connector for engine, transmission, ABS and airbag	1 (left side of heater box)

15.1.2 Connecting the Scan Tool to the Vehicle

This section contains information for connecting the scan tool to the diagnostic connector for testing or troubleshooting. Included in this section are the following:

- “Connections Using the MULTI-1 Adapter” on page 148 (Figure 15-9)
- “Connections Using the MULTI-2 Adapter” on page 149 (Figure 15-13)
- “Connections Using the OBD-II Adapter” on page 150 (Figure 15-14)

Connections Using the MULTI-1 Adapter

To connect the MULTI-1 adapter (Figure 15-9) to a Subaru vehicle, a 12 volt power cable (Figure 15-11, Figure 15-12) and the ground adapter (Figure 15-10) must be used. Connect the MULTI-1 adapter as shown in (Figure 15-9). Connect the blue wire of the MULTI-1 adapter to the vehicle Check connector and pin designated in (Table 15-9).

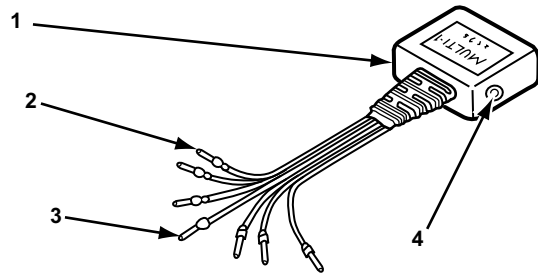

- 1— MULTI-1 adapter
- 2— Ground - black wire (connect the ground adapter here) (Figure 15-10)
- 3— MULTI-1 blue wire (see Table 15-9 for connection to vehicle connector)
- 4— 12 volt power jack (connect the power cable here) (Figure 15-11, Figure 15-12)

Figure 15-9 MULTI-1 adapter

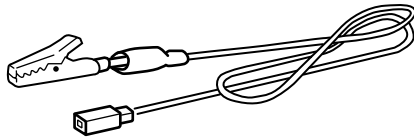

Figure 15-10 Ground adapter

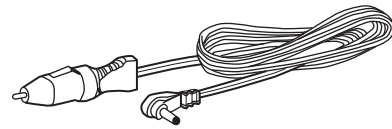

Figure 15-11 Lighter power cable

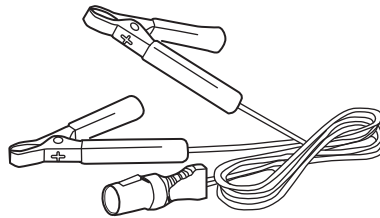
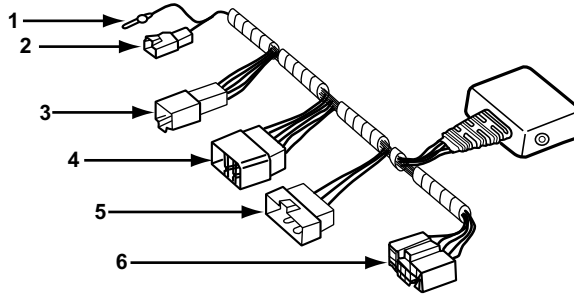

Figure 15-12 Battery power cable

Connections Using the MULTI-2 Adapter

The MULTI-2 adapter can be used on many Asian import vehicles. The MULTI-2 adapter connector "C" is designed to connect to some Subaru vehicles equipped with a 9-pin Check connector. Connect a 12 volt power cable (Figure 15-11, Figure 15-12) and the ground adapter (Figure 15-10) as shown in Figure 15-13. See Table 15-9 for applicable vehicles.



- 1— Ground - black wire (connect the ground adapter here) (Figure 15-10)
- 2— Mazda & Ford (MULTI-2E)
- 3— Isuzu & Geo with GM system (MULTI-2D)
- 4— Subaru (MULTI-2C)
- 5— Mazda & Ford (MULTI-2B)
- 6— Special applications (MULTI-2A)
- 7— 12 volt power jack (connect the power cable here) (Figure 15-11, Figure 15-12)

Figure 15-13 MULTI-2 Asian adapter

Connections Using the OBD-II Adapter

The 16-pin OBD-II adapter is used on some Subaru models beginning in 1995 and all 1996 and later OBD-II equipped vehicles. Use the OBD-II adapter with the specified Personality Key™ device to read engine and transmission codes as shown in “OBD-II adapter and Personality Key™”. See Table 15-9 for applicable vehicles.

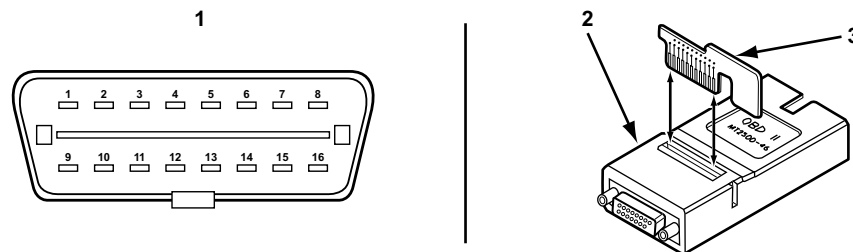

Figure 15-14 OBD-II adapter and Personality Key™

- 1— 16-pin DLC
- 2— OBD-II adapter
- 3— Personality Key™

15.1.3 Reading Engine Codes

The following contains information for connecting the scan tool to the vehicle for reading engine codes. Included in this section are the following:

- “Subaru Vehicle Connection Table” on page 151 (Table 15-9)
- “Subaru Vehicle Connection Diagrams” on page 159 (Figure 15-15 to Figure 15-31)

Subaru Vehicle Connection Table

Find the vehicle being tested in Table 15-9 “Subaru Vehicle Connections Table” and then go to the correct “Reading Codes Connector” figure number shown for the vehicle.

Table 15-9 Subaru Vehicle Connections Table (part 1 of 9)

Vehicle Identification Number				Adapter				User's Manual Section and Figure Numbers			
Year	Model	Engine	Fuel System	MULTI-1	MULTI2C	Power Pac	OBD-II	Reading Codes Connector	D-Check Connectors	Read Memory Connectors	Code Reading Connector Locations
1983	Brat	1.8L H4	2BBL	X				Figure 15-19	Figure 15-33		Table 15-1
		1.8L H4T	MFI	X				Figure 15-15	Figure 15-35		Table 15-2
	Hardtop	All	All	X				Figure 15-19	Figure 15-33		Table 15-1
	Hatchback	All	All	X				Figure 15-19	Figure 15-33		Table 15-1
	Sedan	All	All	X				Figure 15-19	Figure 15-33		Table 15-1
	Wagon	1.8L H4	1BBL	X				Figure 15-19	Figure 15-33		Table 15-1
		1.8L H4	2BBL	X				Figure 15-19	Figure 15-33		Table 15-1
1.8L H4T		MFI	X				Figure 15-15	Figure 15-35		Table 15-2	
1984	Brat	1.8L H4	2BBL	X				Figure 15-28	Figure 15-34		Table 15-1
		1.8L H4-T	MFI	X				Figure 15-16	Figure 15-35		Table 15-2
	Hardtop	1.6L H4	2BBL	X				Figure 15-28	Figure 15-34		Table 15-1
		1.8L H4	1BBL	X				Figure 15-28	Figure 15-34		Table 15-1
		1.8L H4	2BBL	X				Figure 15-28	Figure 15-34		Table 15-1
		1.8L H4-T	MFI	X				Figure 15-16	Figure 15-35		Table 15-2
	Hatchback	All	All	X				Figure 15-28	Figure 15-34		Table 15-1
	Sedan	All	All	X				Figure 15-28	Figure 15-34		Table 15-1
	Wagon	1.8L H4	1BBL	X				Figure 15-28	Figure 15-34		Table 15-1
		1.8L H4	2BBL	X				Figure 15-28	Figure 15-34		Table 15-1
1.8L H4-T		MFI	X				Figure 15-16	Figure 15-35		Table 15-2	
1985	Brat	All	All	X				Figure 15-21	Figure 15-36		Table 15-4
	Hatchback	All	All	X				Figure 15-21	Figure 15-36		Table 15-1
	Sedan	1.8L H4	2BBL	X				Figure 15-21	Figure 15-36		Table 15-1
		1.8L H4	MFI	X				Figure 15-29	Figure 15-35		Table 15-4
		1.8L H4-T	MFI	X				Figure 15-29	Figure 15-35		Table 15-4
	Wagon	1.8L H4	2BBL	X				Figure 15-21	Figure 15-36		Table 15-1
		1.8L H4	MFI	X				Figure 15-29	Figure 15-35		Table 15-4
	XT	1.8L H4	MFI	X				Figure 15-29	Figure 15-37		Table 15-7
1.8L H4-T		MFI	X				Figure 15-29	Figure 15-37		Table 15-7	

Table 15-9 Subaru Vehicle Connections Table (part 2 of 9)

Vehicle Identification Number				Adapter				User's Manual Section and Figure Numbers			
Year	Model	Engine	Fuel System	MULTI-I	MULTI-C	Power Pac	OBD-II	Reading Codes Connector	D-Check Connectors	Read Memory Connectors	Code Reading Connector Locations
1986	Brat	All	All	X				Figure 15-26, Figure 15-27	Figure 15-36		Table 15-4
	Coupe	1.8L H4	2BBL	X				Figure 15-21	Figure 15-36		Table 15-1
		1.8L H4	SPI	X				Figure 15-22, Figure 15-23	Figure 15-38	Figure 15-38	Table 15-4
		1.8L H4-T	MFI	X				Figure 15-29	Figure 15-35		Table 15-4
	Sedan	1.8L H4	2BBL	X				Figure 15-21	Figure 15-36		Table 15-1
		1.8L H4	SPI	X				Figure 15-22, Figure 15-23	Figure 15-38	Figure 15-38	Table 15-4
		1.8L H4-T	MFI	X				Figure 15-29	Figure 15-35		Table 15-4
	Wagon	1.8L H4	2BBL	X				Figure 15-21	Figure 15-36		Table 15-1
		1.8L H4	SPI	X				Figure 15-22, Figure 15-23	Figure 15-38	Figure 15-38	Table 15-4
		1.8L H4-T	MFI	X				Figure 15-29	Figure 15-35		Table 15-4
	XT	1.8L H4	MFI	X				Figure 15-29	Figure 15-37		Table 15-7
		1.8L H4-T	MFI	X				Figure 15-29	Figure 15-37		Table 15-7
1987	Brat	All	All	X				Figure 15-26, Figure 15-27	Figure 15-36		Table 15-4
	Coupe	1.8L H4	2BBL	X				Figure 15-21	Figure 15-36		Table 15-1
		1.8L H4	SPI	X				Figure 15-24, Figure 15-25	Figure 15-40	Figure 15-40	Table 15-4
		1.8L H4-T	MFI	X				Figure 15-21	Figure 15-35		Table 15-4
	Hatchback	1.8L H4	2BBL	X				Figure 15-21	Figure 15-36		Table 15-1
		1.8L H4	2BBL	X				Figure 15-26, Figure 15-27	Figure 15-36		Table 15-1
	Justy	All	All	X				Figure 15-20	Figure 15-39	Figure 15-39	Table 15-3
	Sedan	1.8L H4	2BBL	X				Figure 15-21	Figure 15-36		Table 15-1
		1.8L H4	SPI	X				Figure 15-24, Figure 15-25	Figure 15-40	Figure 15-40	Table 15-4
		1.8L H4-T	MFI	X				Figure 15-21	Figure 15-35		Table 15-4
	Wagon	1.8L H4	2BBL	X				Figure 15-21	Figure 15-36		Table 15-1
		1.8L H4	SPI	X				Figure 15-24, Figure 15-25	Figure 15-40	Figure 15-40	Table 15-4
1.8L H4-T		MFI	X				Figure 15-21	Figure 15-35		Table 15-4	
XT	1.8L H4	MFI	X				Figure 15-21	Figure 15-41	Figure 15-41	Table 15-7	
	1.8L H4-T	MFI	X				Figure 15-21	Figure 15-41	Figure 15-41	Table 15-7	

Table 15-9 Subaru Vehicle Connections Table (part 3 of 9)

Vehicle Identification Number				Adapter				User's Manual Section and Figure Numbers			
Year	Model	Engine	Fuel System	MULTI-1	MULTI2C	Power Pac	OBD-II	Reading Codes Connector	D-Check Connectors	Read Memory Connectors	Code Reading Connector Locations
1988	Coupe	1.8L H4	SPI	X				Figure 15-24, Figure 15-25	Figure 15-40	Figure 15-40	Table 15-4
		1.8L H4-T	MFI	X				Figure 15-30	Figure 15-42	Figure 15-42	Table 15-4
	Hatchback	All	All	X				Figure 15-26, Figure 15-27	Figure 15-36		Table 15-1
	Justy	All	All	X	X			Figure 15-17, Figure 15-18	Figure 15-42	Figure 15-42	Table 15-3
	Sedan	1.8L H4	SPI	X				Figure 15-24, Figure 15-25	Figure 15-40	Figure 15-40	Table 15-4
		1.8L H4-T	MFI	X				Figure 15-30	Figure 15-42	Figure 15-42	Table 15-4
	Wagon	1.8L H4	SPI	X				Figure 15-24, Figure 15-25	Figure 15-40	Figure 15-40	Table 15-4
		1.8L H4-T	MFI	X				Figure 15-30	Figure 15-42	Figure 15-42	Table 15-4
XT	All	All	X				Figure 15-24, Figure 15-25	Figure 15-41	Figure 15-41	Table 15-7	
1989	Coupe	1.8L H4	SPI	X	X			Figure 15-17, Figure 15-18	Figure 15-40	Figure 15-40	Table 15-4
		1.8L H4-T	MFI	X				Figure 15-30	Figure 15-42	Figure 15-42	Table 15-4
	Hatchback	All	All	X				Figure 15-26, Figure 15-27	Figure 15-36		Table 15-1
	Justy	All	All	X	X			Figure 15-17, Figure 15-18	Figure 15-42	Figure 15-42	Table 15-3
	Sedan	1.8L H4	SPI	X	X			Figure 15-17, Figure 15-18	Figure 15-40	Figure 15-40	Table 15-4
		1.8L H4-T	MFI	X				Figure 15-30	Figure 15-42	Figure 15-42	Table 15-4
	Touring Wagon	1.8L H4	SPI	X	X			Figure 15-17, Figure 15-18	Figure 15-40	Figure 15-40	Table 15-4
		1.8L H4-T	MFI	X				Figure 15-30	Figure 15-42	Figure 15-42	Table 15-4
	Wagon	1.8L H4	SPI	X	X			Figure 15-17, Figure 15-18	Figure 15-40	Figure 15-40	Table 15-4
		1.8L H4-T	MFI	X				Figure 15-30	Figure 15-42	Figure 15-42	Table 15-4
XT	All	All	X				Figure 15-21	Figure 15-41	Figure 15-41	Table 15-7	

Table 15-9 Subaru Vehicle Connections Table (part 4 of 9)

Vehicle Identification Number				Adapter				User's Manual Section and Figure Numbers			
Year	Model	Engine	Fuel System	MULTI-1	MULTI2C	Power Pac	OBD-II	Reading Codes Connector	D-Check Connectors	Read Memory Connectors	Code Reading Connector Locations
1990	Coupe	All	SPI	X	X			Figure 15-17, Figure 15-18	Figure 15-40	Figure 15-40	Table 15-4
		All	MFI	X	X			Figure 15-17, Figure 15-18	Figure 15-42	Figure 15-42	Table 15-4
	Justy	1.2L L3	2BBL	X	X			Figure 15-17, Figure 15-18	Figure 15-42	Figure 15-42	Table 15-3
		1.2L L3	MFI			X		Power Pac	Figure 15-42	Figure 15-42	Table 15-3
	Legacy Touring Wagon	All	All	X	X			Figure 15-17, Figure 15-18	Figure 15-42	Figure 15-42	Table 15-5
	Legacy Wagon	All	All	X	X			Figure 15-17, Figure 15-18	Figure 15-42	Figure 15-42	Table 15-5
	Sedan	All	SPI	X	X			Figure 15-17, Figure 15-18	Figure 15-40	Figure 15-40	Table 15-4
		All	MFI	X	X			Figure 15-17, Figure 15-18	Figure 15-42	Figure 15-42	Table 15-4
	Touring Wagon	All	SPI	X	X			Figure 15-17, Figure 15-18	Figure 15-40	Figure 15-40	Table 15-4
		All	MFI	X	X			Figure 15-17, Figure 15-18	Figure 15-42	Figure 15-42	Table 15-4
	Wagon	All	SPI	X	X			Figure 15-17, Figure 15-18	Figure 15-40	Figure 15-40	Table 15-4
		All	MFI	X	X			Figure 15-17, Figure 15-18	Figure 15-42	Figure 15-42	Table 15-4
XT	All	All	X				Figure 15-17, Figure 15-18	Figure 15-41	Figure 15-41	Table 15-7	
1991	Justy	1.2L L3	2BBL	X	X			Figure 15-17, Figure 15-18	Figure 15-42	Figure 15-42	Table 15-3
		1.2L L3	MFI			X		Power Pac	Figure 15-42	Figure 15-42	Table 15-3
	Legacy Wagon	All	All	X	X			Figure 15-17, Figure 15-18	Figure 15-42	Figure 15-42	Table 15-5
	Sedan	1.8L H4	SPI	X	X			Figure 15-17, Figure 15-18	Figure 15-40	Figure 15-40	Table 15-4
		2.2L H4	MFI	X	X			Figure 15-17, Figure 15-18	Figure 15-42	Figure 15-42	Table 15-4
	Wagon	All	All	X	X			Figure 15-17, Figure 15-18	Figure 15-40	Figure 15-40	Table 15-4
	XT	All	All	X				Figure 15-21	Figure 15-41	Figure 15-41	Table 15-7

Table 15-9 Subaru Vehicle Connections Table (part 5 of 9)

Vehicle Identification Number				Adapter				User's Manual Section and Figure Numbers				
Year	Model	Engine	Fuel System	MULTI-1	MULTI2C	Power Pac	OBD-II	Reading Codes Connector	D-Check Connectors	Read Memory Connectors	Code Reading Connector Locations	
1992	Justy	1.2L L3	2BBL	X	X			Figure 15-17, Figure 15-18	Figure 15-42	Figure 15-42	Table 15-3	
		1.2L L3	MFI			X		Power Pac	Figure 15-42	Figure 15-42	Table 15-3	
	Legacy Wagon	All	All	X	X			Figure 15-17, Figure 15-18	Figure 15-42	Figure 15-42	Table 15-5	
	Sedan	1.8L H4-T	MFI	X	X				Figure 15-17, Figure 15-18	Figure 15-42	Figure 15-42	Table 15-4
		1.8L H4	SPI	X	X				Figure 15-17, Figure 15-18	Figure 15-40	Figure 15-40	Table 15-4
		2.2L H4	MFI	X	X				Figure 15-17, Figure 15-18	Figure 15-42	Figure 15-42	Table 15-4
		2.2L H4-T	MFI	X	X				Figure 15-17, Figure 15-18	Figure 15-42	Figure 15-42	Table 15-4
	SVX	All	All			X		Power Pac	Figure 15-43	Figure 15-43	Table 15-6	
	Wagon	1.8L H4-T	MFI	X	X				Figure 15-17, Figure 15-18	Figure 15-42	Figure 15-42	Table 15-4
		1.8L H4	SPI	X	X				Figure 15-17, Figure 15-18	Figure 15-40	Figure 15-40	Table 15-4
1993	Impreza Wagon	All	All			X		Power Pac	Figure 15-42	Figure 15-42	Table 15-5	
	Justy	1.2L L3	2BBL	X	X			Figure 15-17, Figure 15-18	Figure 15-42	Figure 15-42	Table 15-3	
		1.2L L3	MFI			X			Power Pac	Figure 15-42	Figure 15-42	Table 15-3
	Legacy Wagon	All	All	X	X			Figure 15-17, Figure 15-18	Figure 15-42	Figure 15-42	Table 15-5	
	Sedan	1.8L H4	MFI			X			Power Pac	Figure 15-42	Figure 15-42	Table 15-4
		1.8L H4	SPI	X	X				Figure 15-17, Figure 15-18	Figure 15-40	Figure 15-40	Table 15-4
		2.2L H4	MFI	X	X				Figure 15-17, Figure 15-18	Figure 15-42	Figure 15-42	Table 15-4
		2.2L H4-T	MFI	X	X				Figure 15-17, Figure 15-18	Figure 15-42	Figure 15-42	Table 15-4
SVX	All	All			X		Power Pac	Figure 15-43	Figure 15-43	Table 15-6		
Wagon	All	All	X	X			Figure 15-17, Figure 15-18	Figure 15-40	Figure 15-40	Table 15-4		

Table 15-9 Subaru Vehicle Connections Table (part 6 of 9)

Vehicle Identification Number				Adapter				User's Manual Section and Figure Numbers			
Year	Model	Engine	Fuel System	MULTI-1	MULTI2C	Power Pac	OBD-II	Reading Codes Connector	D-Check Connectors	Read Memory Connectors	Code Reading Connector Locations
1994	Impreza Wagon	All	All			X		Power Pac	Figure 15-42	Figure 15-42	Table 15-5
	Justy	1.2L L3	2BBL	X	X			Figure 15-17, Figure 15-18	Figure 15-42	Figure 15-42	Table 15-3
		1.2L L3	MFI			X		Power Pac	Figure 15-42	Figure 15-42	Table 15-3
	Legacy Wagon	All	All	X	X			Figure 15-17, Figure 15-18	Figure 15-42	Figure 15-42	Table 15-5
	Sedan	1.8L H4	MFI			X		Power Pac	Figure 15-42	Figure 15-42	Table 15-4
		1.8L H4	SPI	X	X			Figure 15-17, Figure 15-18	Figure 15-40	Figure 15-40	Table 15-4
		2.2L H4	MFI	X	X			Figure 15-17, Figure 15-18	Figure 15-42	Figure 15-42	Table 15-4
		2.2L H4-T	MFI	X	X			Figure 15-17, Figure 15-18	Figure 15-42	Figure 15-42	Table 15-4
SVX	All	All			X		Power Pac	Figure 15-43	Figure 15-43	Table 15-6	
Wagon	All	All	X	X			Figure 15-17, Figure 15-18	Figure 15-40	Figure 15-40	Table 15-4	
1995	Impreza Coupe	1.8L H4	MFI			X		Power Pac	Figure 15-42	Figure 15-42	Table 15-5
		2.2L H4	MFI				X	Figure 15-31			Table 15-5
	Impreza Sedan	1.8L H4	MFI			X		Power Pac	Figure 15-42	Figure 15-42	Table 15-5
		2.2L H4	MFI				X	Figure 15-31			Table 15-5
	Impreza Wagon	1.8L H4	MFI			X		Power Pac	Figure 15-42	Figure 15-42	Table 15-5
		2.2L H4	MFI				X	Figure 15-31			Table 15-5
	Legacy Sedan	All	All				X	Figure 15-31			Table 15-8
	Legacy Wagon	All	All				X	Figure 15-31			Table 15-8
SVX	All	All			X		Power Pac	Figure 15-43	Figure 15-43	Table 15-6	
1996 to 2005	All	All	All				X	Figure 15-31			Table 15-8
1996	Impreza Coupe	All	All					OBD-II			
	Impreza Sedan	All	All					OBD-II			
	Impreza Wagon	All	All					OBD-II			
	Legacy Outback	All	All					OBD-II			
	Legacy Sedan	All	All					OBD-II			
	Legacy Wagon	All	All					OBD-II			
	SVX	All	All					OBD-II			

Table 15-9 Subaru Vehicle Connections Table (part 7 of 9)

Vehicle Identification Number				Adapter				User's Manual Section and Figure Numbers			
Year	Model	Engine	Fuel System	MULTI-1	MULTI2C	Power Pac	OBD-II	Reading Codes Connector	D-Check Connectors	Read Memory Connectors	Code Reading Connector Locations
1997	Impreza Coupe	All	All					OBD-II			
	Impreza Sedan	All	All					OBD-II			
	Impreza Wagon	All	All					OBD-II			
	Legacy Outback	All	All					OBD-II			
	Legacy Sedan	All	All					OBD-II			
	Legacy Wagon	All	All					OBD-II			
	SVX	All	All					OBD-II			
1998	Impreza Coupe	All	All					OBD-II			
	Impreza Sedan	All	All					OBD-II			
	Legacy Outback	All	All					OBD-II			
	Legacy Sedan	All	All					OBD-II			
	Legacy Wagon	All	All					OBD-II			
	Wagon	All	All					OBD-II			
1999	Impreza Coupe	All	All					OBD-II			
	Impreza Sedan	All	All					OBD-II			
	Legacy Outback	All	All					OBD-II			
	Legacy Sedan	All	All					OBD-II			
	Legacy Wagon	All	All					OBD-II			
	Wagon	All	All					OBD-II			
2000	Impreza Coupe	All	All					OBD-II			
	Impreza Sedan	All	All					OBD-II			
	Legacy Sedan	All	All					OBD-II			
	Legacy Wagon	All	All					OBD-II			
	Wagon	All	All					OBD-II			

Table 15-9 Subaru Vehicle Connections Table (part 8 of 9)

Vehicle Identification Number				Adapter				User's Manual Section and Figure Numbers			
Year	Model	Engine	Fuel System	MULTI-1	MULTI2C	Power Pac	OBD-II	Reading Codes Connector	D-Check Connectors	Read Memory Connectors	Code Reading Connector Locations
2001	Forester	All	All					OBD-II			
	Impreza Coupe	All	All					OBD-II			
	Impreza Sedan	All	All					OBD-II			
	Impreza Wagon	All	All					OBD-II			
	Legacy Sedan	All	All					OBD-II			
	Legacy Wagon	All	All					OBD-II			
2002	Forester	All	All					OBD-II			
	Impreza Sedan	All	All					OBD-II			
	Impreza Wagon	All	All					OBD-II			
	Legacy/Outback Sedan	All	All					OBD-II			
	Legacy/Outback Wagon	All	All					OBD-II			
2003	Baja	All	All					OBD-II			
	Forester	All	All					OBD-II			
	Impreza Sedan	All	All					OBD-II			
	Impreza Wagon	All	All					OBD-II			
	Legacy/Outback Sedan	All	All					OBD-II			
	Legacy/Outback Wagon	All	All					OBD-II			
2004	Baja	All	All					OBD-II			
	Forester	All	All					OBD-II			
	Impreza Sedan	All	All					OBD-II			
	Impreza Wagon	All	All					OBD-II			
	Legacy/Outback Sedan	All	All					OBD-II			
	Legacy/Outback Wagon	All	All					OBD-II			

Table 15-9 Subaru Vehicle Connections Table (part 9 of 9)

Vehicle Identification Number				Adapter				User's Manual Section and Figure Numbers			
Year	Model	Engine	Fuel System	MULTI-1	MULTI2C	Power Pac	OBD-II	Reading Codes Connector	D-Check Connectors	Read Memory Connectors	Code Reading Connector Locations
2005	Baja	All	All					OBD-II			
	Forester	All	All					OBD-II			
	Impreza Sedan	All	All					OBD-II			
	Impreza Wagon	All	All					OBD-II			
	Legacy/Outback Sedan	All	All					OBD-II			
	Legacy/Outback Wagon	All	All					OBD-II			
2006	B9 Tribeca	All	All					OBD-II			
	Baja	All	All					OBD-II			
	Forester	All	All					OBD-II			
	Impreza Sedan	All	All					OBD-II			
	Impreza Wagon	All	All					OBD-II			
	Legacy/Outback Sedan	All	All					OBD-II			
	Legacy/Outback Wagon	All	All					OBD-II			

Subaru Vehicle Connection Diagrams

The following procedures contain directions and diagrams for connecting various subaru Check connectors to the scan tool.



NOTE:

Procedures are specific to each type of connector. Some procedures are specific down to the pin number and color of the Check connector. Be sure that the connector you are using matches the description before you proceed. See Table 15-9 for a guide to the correct vehicle application.



To read codes on vehicles with a 7-pin Check connector:

- Connect the blue wire of the MULTI-1 adapter to Check connector pin 3 (Figure 15-15). Use the ground extension on the MULTI-1 black wire.

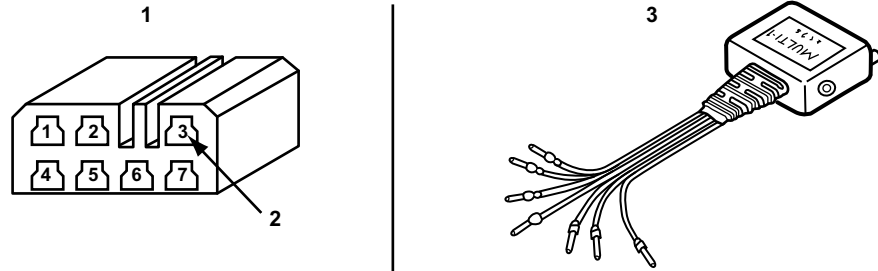

- 1— 7-pin Check connector (color: brown)
- 2— Pin 3 (connect the MULTI-1 blue wire here)
- 3— MULTI-1 adapter

Figure 15-15 7-pin Check connector



To read codes on vehicles with a 9-pin Check connector:

- Connect the blue wire of the MULTI-1 adapter to Check connector pin 4 (Figure 15-16).

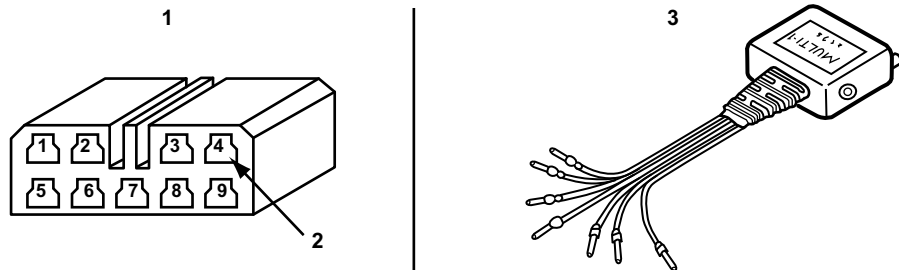

- 1— 9-pin Check connector (color: yellow)
- 2— Pin 4 (connect the MULTI-1 blue wire here)
- 3— MULTI-1 adapter

Figure 15-16 Yellow 9-pin Check connector



To read codes on vehicles with a 9-pin Check connector:

- Codes can be read using a MULTI-2C or a MULTI-1 adapter. To read codes, connect the MULTI-2C adapter to the Check connector (Figure 15-17) or connect the blue wire of the MULTI-1 adapter to pin 8 of the Check connector (Figure 15-18).

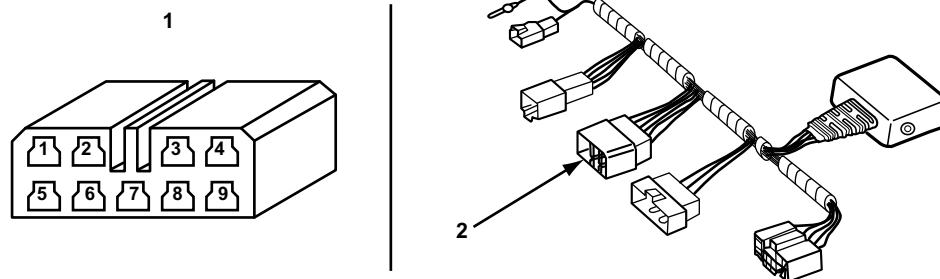

- 1— 9-pin Check connector (color: varies)
- 2— MULTI-2C adapter

Figure 15-17 9-pin Check connector and MULTI-2C

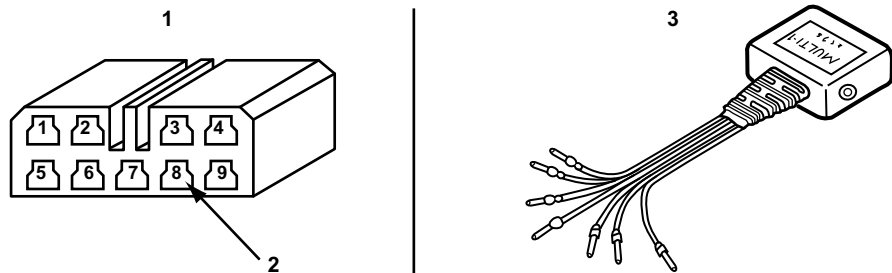

- 1— 9-pin Check connector (color: varies)
 2— Pin 8 (connect the MULTI-1 blue wire here)
 3— MULTI-1 adapter

Figure 15-18 9-pin Check connector and MULTI-1



To read codes on vehicles with an 11-pin Check connector:

- Connect the blue wire of the MULTI-1 adapter to Check connector pin 13 (Figure 15-19).

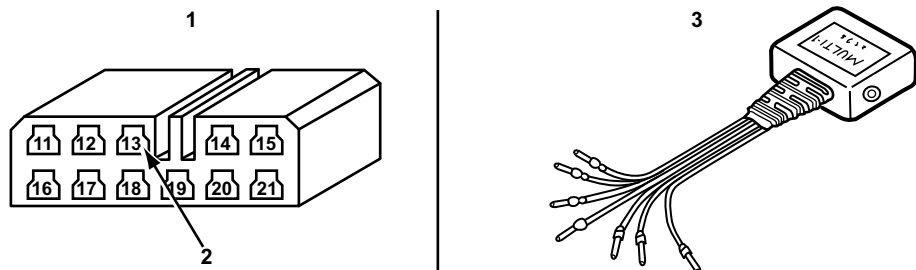

- 1— 11-pin Check connector (color: brown)
 2— Pin 13 (connect the MULTI-1 blue wire here)
 3— MULTI-1 adapter

Figure 15-19 11-pin Check connector



To read codes on vehicles with an 11-pin Check connector:

- Connect the blue wire of the MULTI-1 adapter to Check connector pin 15 (Figure 15-20).

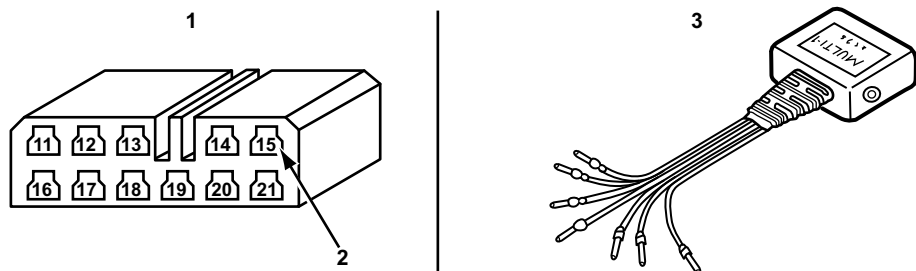

- 1— 11-pin Check connector (color: varies)
 2— Pin 15 (connect the MULTI-1 blue wire here)
 3— MULTI-1 adapter

Figure 15-20 11-pin Check Connector



To read codes on vehicles with a 13-pin Check connector:

- Connect the MULTI-1 adapter blue wire to Check connector pin 10 (Figure 15-21).

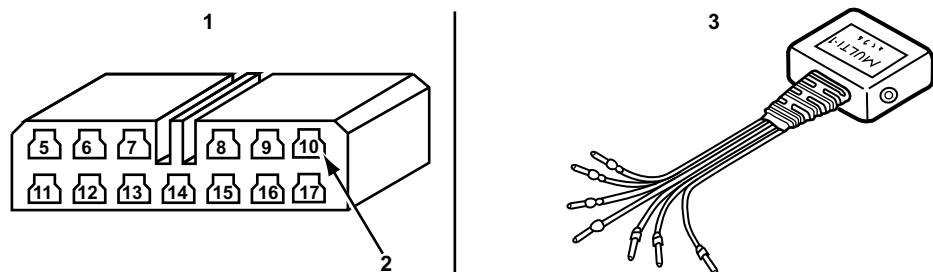

- 1— 13-pin Check connector (color: yellow)
 2— Pin 10 (connect the MULTI-1 blue wire here)
 3— MULTI-1 adapter

Figure 15-21 13-pin Check connector



To read codes on vehicles with a 13-pin Check connector:

- Connection depends on the color of the 13-pin Check connector:
 - a. If natural, connect the MULTI-1 blue wire to Check connector pin 11 (Figure 15-22).
 - b. If yellow, connect the MULTI-1 blue wire to Check connector pin 6 (Figure 15-23).

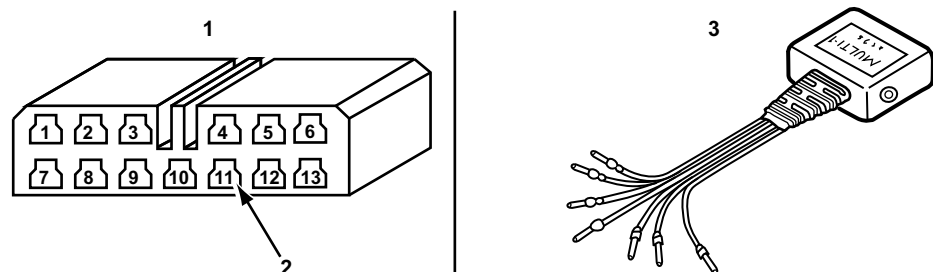

- 1— 13-pin Check connector (color: natural)
 2— Pin 11 (connect the MULTI-1 blue wire here)
 3— MULTI-1 adapter

Figure 15-22 13-pin Check connector

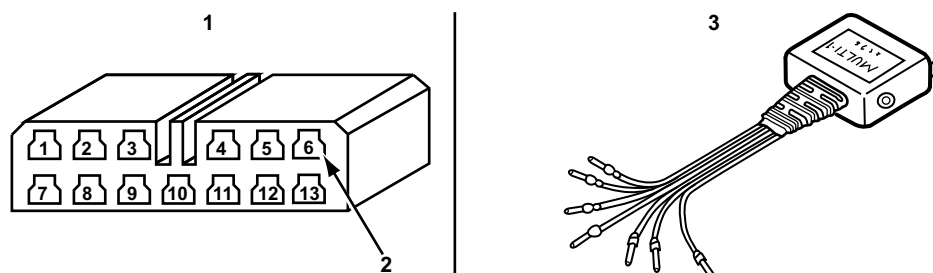

- 1— 13-pin Check connector (Color: yellow)
 2— Pin 6 (connect the MULTI-1 blue wire here)
 3— MULTI-1 adapter

Figure 15-23 13-pin Check connector



To read codes on vehicles with a 13-pin Check connector:

- Connection depends on the color and/or location of the 13-pin Check connector:
 - a. If your Check connector is under the hood and black, connect the blue wire of the MULTI-1 adapter to pin 5 of the Check connector (Figure 15-24).
 - b. If your Check connector is located under the dash or inside the trunk, connect the blue wire of the MULTI-1 adapter to pin 6 of the Check connector (Figure 15-25).

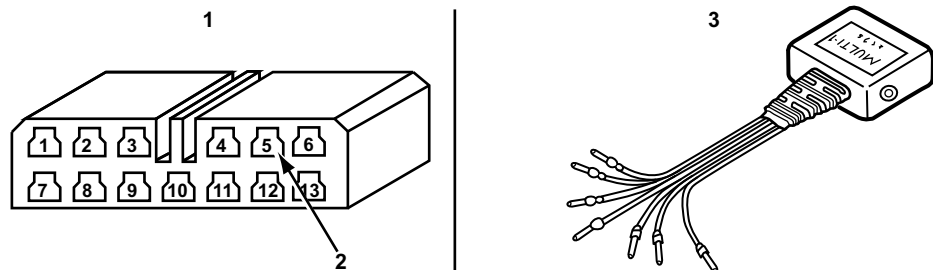

- 1— 13-pin Check connector (color: black, location: under hood)
 2— Pin 5 (connect the MULTI-1 blue wire here)
 3— MULTI-1 adapter

Figure 15-24 13-pin Check connector

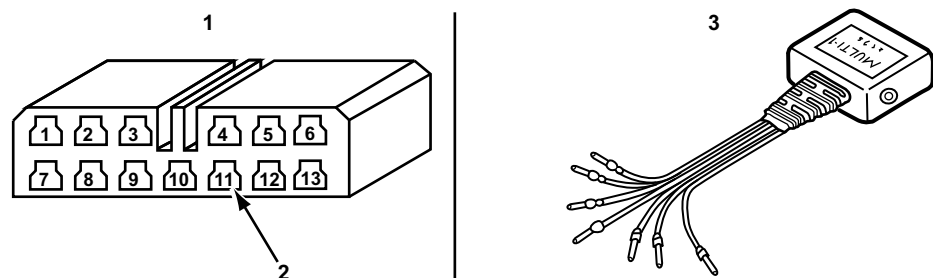

- 1— 13-pin Check connector (color: varies, location: under dash or inside trunk)
 2— Pin 11 (Connect the MULTI-1 blue wire here)
 3— MULTI-1 adapter

Figure 15-25 13-pin Check connector



To read codes on vehicles with a 13-pin or 17-pin Check connector:

- Determine if your Check connector is a 13-pin or a 17-pin Check connector:
 - a. If 13-pin, connect the MULTI-1 blue wire to Check connector pin 11 of the (Figure 15-26).
 - b. If 17-pin, connect the MULTI-1 blue wire to Check connector pin 7 (Figure 15-27).

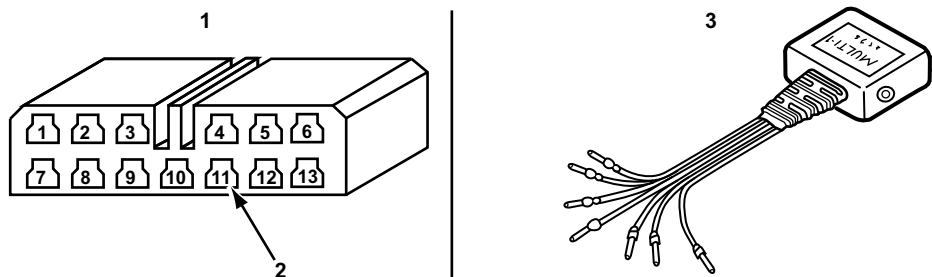

- 1— 13-pin Check connector (color: varies)
- 2— Pin 11 (connect the MULTI-1 blue wire here)
- 3— MULTI-1 adapter

Figure 15-26 13-pin Check connector

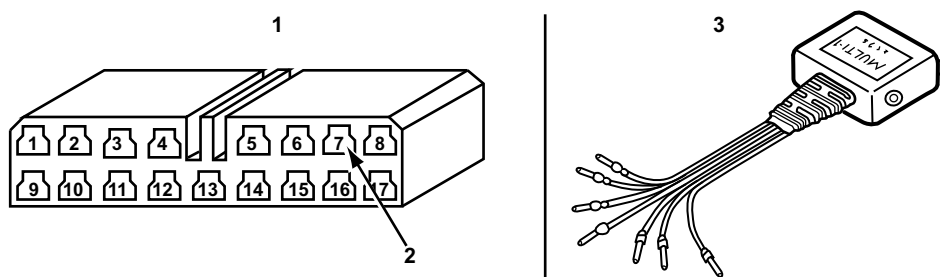

- 1— 17-pin Check connector (color: varies)
- 2— Pin 7 (connect the MULTI-1 blue wire here)
- 3— MULTI-1 adapter

Figure 15-27 17-pin Check connector



To read codes on vehicles with a 17-pin Check connector:

- Connect the MULTI-1 adapter blue wire to Check connector pin 4 (Figure 15-28).

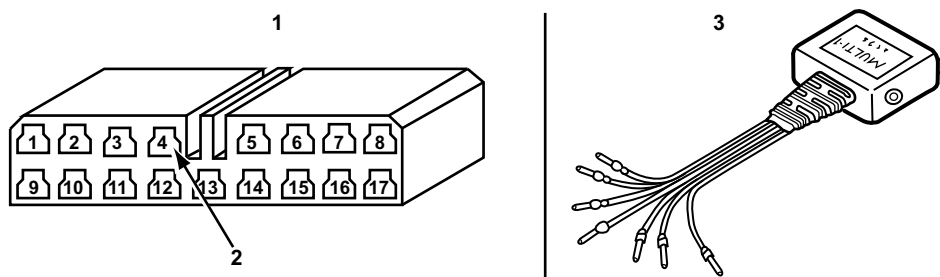

- 1— 17-pin Check connector (color: varies)
- 2— Pin 4 (connect the MULTI-1 blue wire here)
- 3— MULTI-1 adapter

Figure 15-28 17-pin Check connector



To read codes on vehicles with a 17-pin Check connector:

- Connect the blue wire of the MULTI-1 adapter to pin 7 (Figure 15-28).

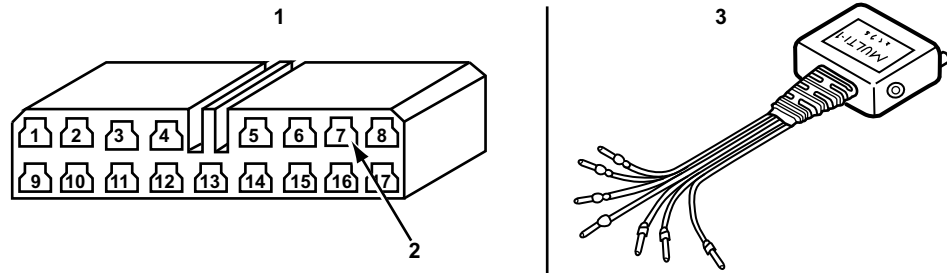

- 1— 17-pin Check connector (color: yellow)
- 2— Pin 7 (connect the MULTI-1 blue wire here)
- 3— MULTI-1 adapter

Figure 15-29 17-pin Check connector



To read codes on vehicles with a 17-pin Check connector:

- Connect the blue wire of the MULTI-1 adapter to Check connector pin 11 (Figure 15-28).

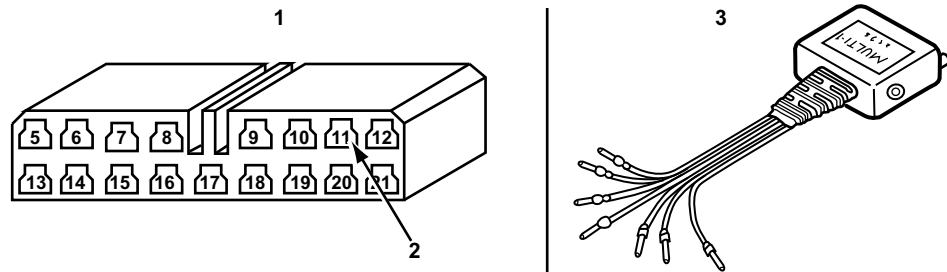

- 1— 17-pin Check connector (color: black)
- 2— Pin 11 (connect the MULTI-1 blue wire here)
- 3— MULTI-1 adapter

Figure 15-30 17-pin Check connector



To read codes from vehicles with a 16-pin OBD-II connector:

- Use the OBD-II adapter with the specified Personality Key™ device (Figure 15-31).

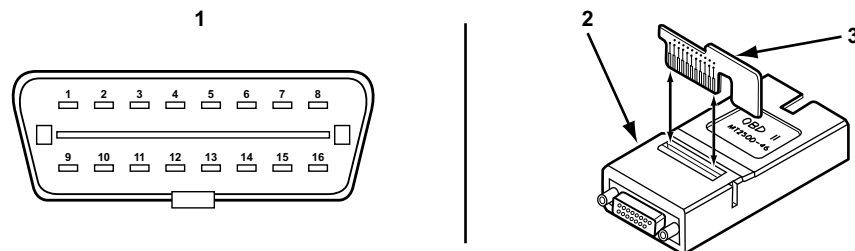

Figure 15-31 16-pin OBD-II connector with adapter and Personality Key™ device

- 1— 16-pin DLC
- 2— OBD-II adapter with Personality Key™

15.1.4 D-Check and Read Memory Connector Locations

D-Check connectors are used on some 1995 models and most 1994 and earlier models. D-Check connectors can be identified easily as a mating pair and are green in color.

Read Memory connectors are used on some 1995 models, most 1986-94 models with fuel injection and some carbureted engines. Read Memory connectors are similar to the D-Check connectors, but are typically black in color.

Connector locations vary by model and may be difficult to locate and identify. Figure 15-32 shows some typical locations where connectors may be found.

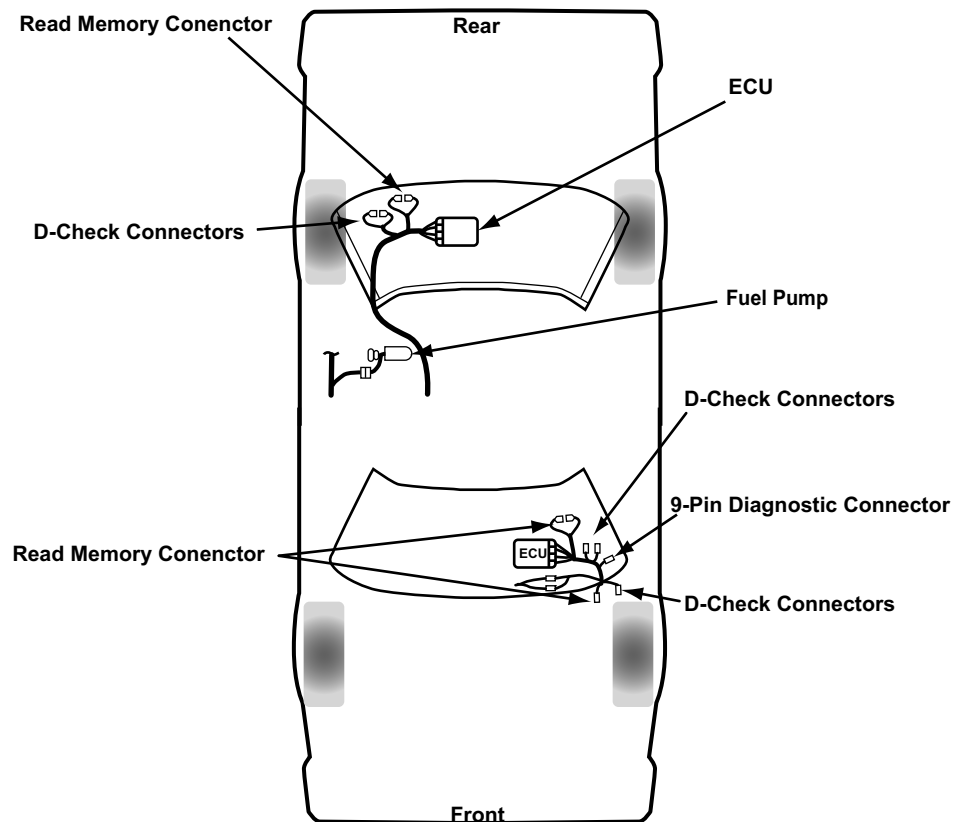

Figure 15-32 Common locations for D-Check and Read Memory connectors

Included in this section are the following connector location diagrams:

- Vehicles without ECM memory (D-Check only)
 - “1983 ECC carbureted” on page 167 (Figure 15-33)
 - “1984 ECC carbureted” on page 167 (Figure 15-34)
 - “1983–84 EGI-MGI (Turbo), 1985–87 all except XT” on page 168 (Figure 15-35)
 - “1985–89 ECC overhead cam” on page 168 (Figure 15-36)
 - “1986–87 XT” on page 169 (Figure 15-37)
- Vehicles with ECM memory (D-Check & Read Memory)
 - “1986 SPI connectors” on page 169 (Figure 15-38)
 - “1987 Justy” on page 170 (Figure 15-39)

- "1987-94 SPI connectors" on page 170 (Figure 15-40)
- "1987-91 XT models (connector in the trunk)" on page 171 (Figure 15-41)
- "1988-94 Justy Carbureted, 1990-94 Justy MFI, 1990-94 Legacy, and 1987-94 L-Series" on page 171 (Figure 15-42)
- "1992-95 SVX models (connectors in left kick panel)" on page 172 (Figure 15-43)

Vehicles without ECM Memory (D-Check Only)

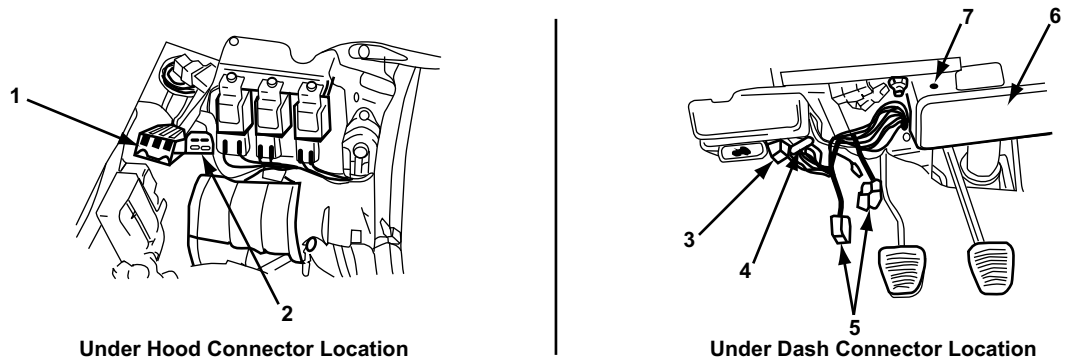

- 1— Check connector 2
- 2— Check connector 1
- 3— Check connector 4
- 4— Check connector 3
- 5— D-Check connectors
- 6— ECU
- 7— ECU LED

Figure 15-33 1983 ECC carbureted

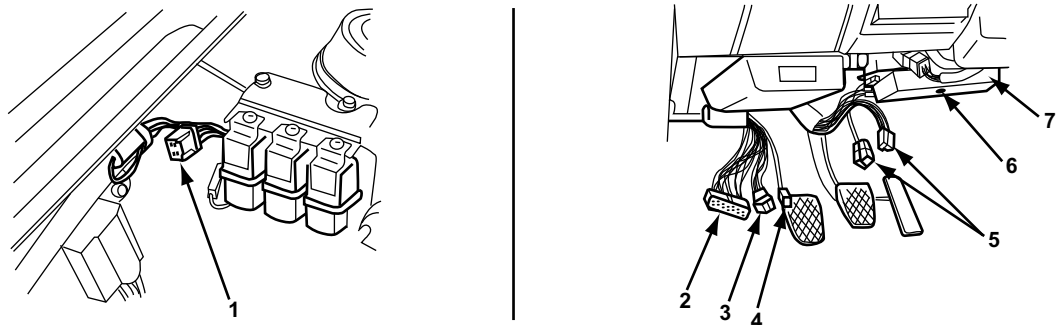

- 1— Check connector 1
- 2— Check connector 2
- 3— Check connector 3
- 4— Check connector 4
- 5— D-Check connectors
- 6— ECU LED
- 7— ECU

Figure 15-34 1984 ECC carbureted

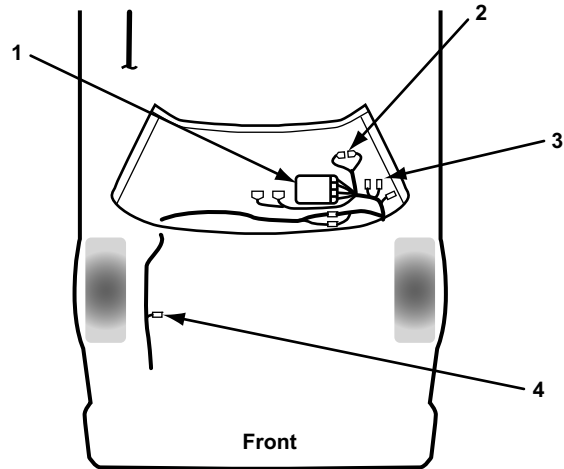

- 1— ECM
- 2— D-Check connectors
- 3— Check connectors 1, 2, and 3
- 4— Check connector 4

Figure 15-35 1983–84 EGI-MGI (Turbo), 1985–87 all except XT

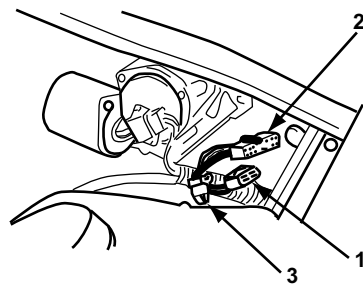

Under Hood Connector Location

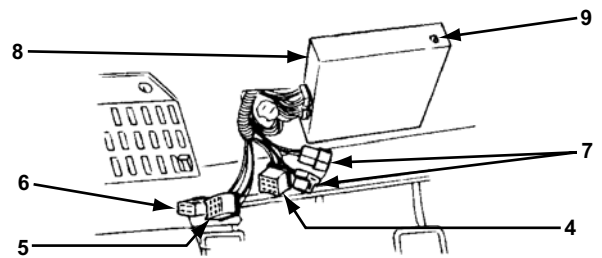

Under Dash Connector Location

- 1— Check connector 1
- 2— Check connector 2
- 3— Check connector 3
- 4— Check connector 4
- 5— Check connector 5
- 6— Check connector 6
- 7— D-Check connectors
- 8— ECU
- 9— ECU LED

Figure 15-36 1985–89 ECC overhead cam

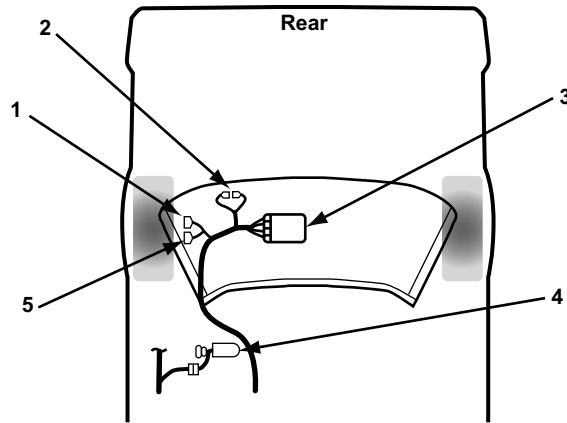

- 1— Check connector 1
- 2— D-Check connectors
- 3— ECM
- 4— Fuel pump
- 5— Check connector 2

Figure 15-37 1986-87 XT

Vehicles with ECM Memory (D-Check and Read Memory)

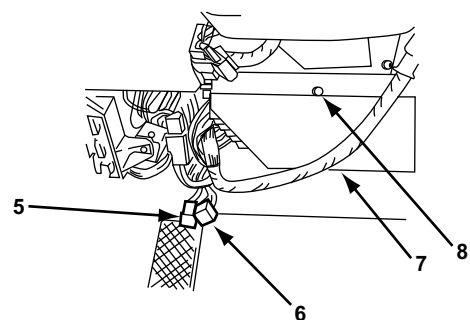
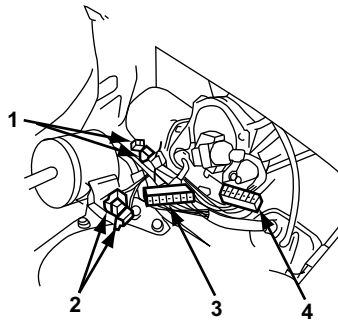

- 1— Read Memory connectors
- 2— D-Check connectors
- 3— Check connector 3
- 4— Check connector 4
- 5— Check connector 1
- 6— Check connector 2
- 7— ECU
- 8— ECU LED

Figure 15-38 1986 SPI connectors

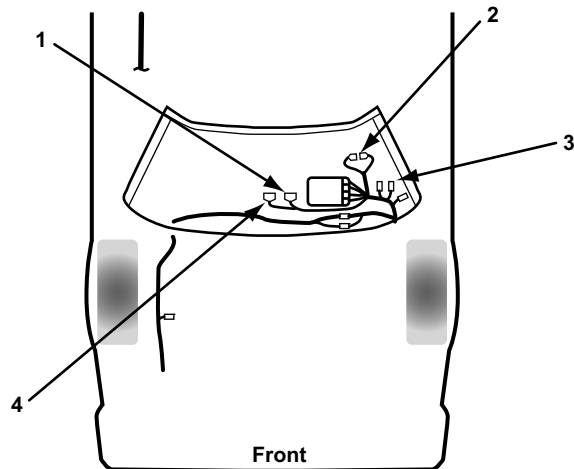

- 1— Fuel pump relay
- 2— Read Memory connectors
- 3— D-Check connectors
- 4— Ignition relay

Figure 15-39 1987 Justy

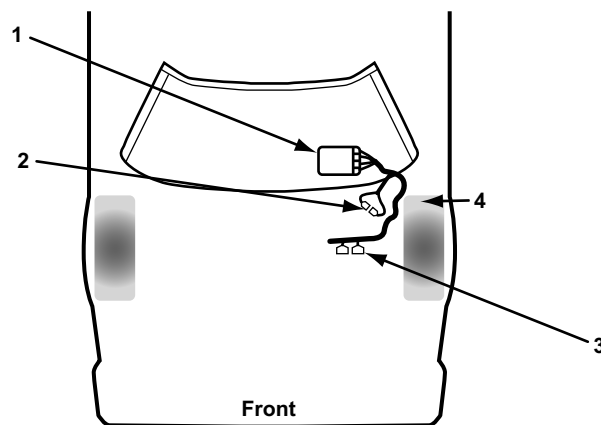

- 1— ECM and Check connector (under dash)
- 2— Read Memory connectors (under hood)
- 3— D-Check connectors (under hood)
- 4— Check connectors (under dash and under hood)

Figure 15-40 1987-94 SPI connectors

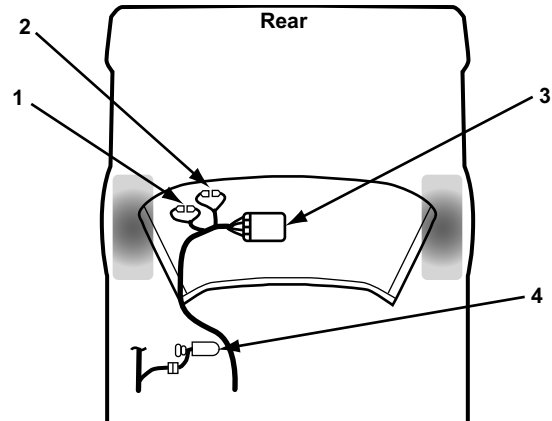

- 1— Read Memory connectors
- 2— D-Check connectors
- 3— ECM
- 4— Fuel pump

Figure 15-41 1987-91 XT models (connector in the trunk)

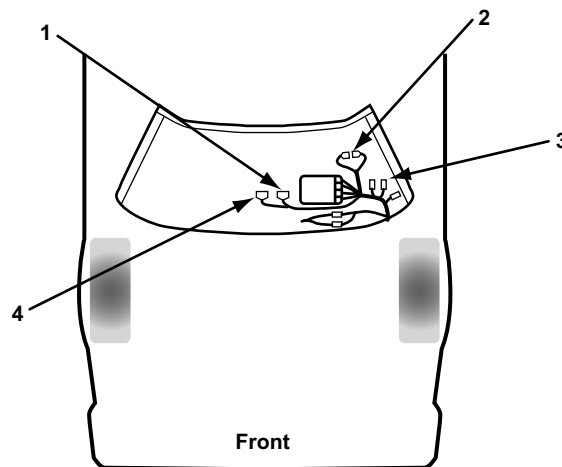

- 1— Fuel pump relay
- 2— Read Memory connectors
- 3— D-Check connectors
- 4— Ignition relay

Figure 15-42 1988-94 Justy Carbureted, 1990-94 Justy MFI, 1990-94 Legacy, and 1987-94 L-Series

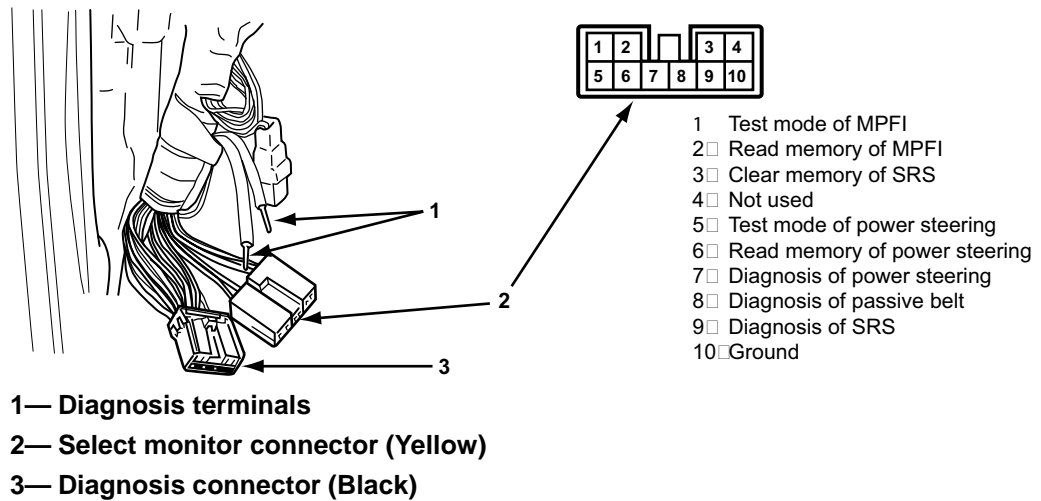

Figure 15-43 1992-95 SVX models (connectors in left kick panel)

15.1.5 Automatic Code Reading

During Subaru automatic code reading, you must perform two diagnostic checks:

- U-Check, or Electronic Control System (ECS) check
- D-Check

The specific procedure for each depends on the model and year of the test vehicle:

- **ECS Check (U-Check)**—All models (do this only if the ECS lamp on the dash is lit)
- **ECC D-Check**—All 1983–89 models except Justy with an electronically controlled carburetor (ECC)
- **Pre-1987 MPI D-Check**—1983–86 vehicles with Multipoint Injection (MPI)
- **1987 Justy EFC D-Check**—1987 Justy with an electronic feedback carburetor (EFC)
- **Justy EFC or MPI D-Check**—1988–90 Justy with an electronic feedback carburetor (EFC) and 1990–91 Justy vehicles with multipoint injection (MPI)
- **SPI or MPI D-Check**—All 1986–94 Single Point Injection (SPI) vehicles and 1987–92 MPI vehicles

Failure to follow the right procedure may result in misreading codes or inaccurate diagnosis.



NOTE:

For transmission codes, see “Transmission Code Reading” on page 180.

ECS Check (U-Check)

The ECM does not have memory capability on most pre-1987 vehicles. The ECM on 1986 models with single-point injection (SPI) and 1983–89 models with an electronically controlled carburetor (ECC) has memory.

IMPORTANT:

Do not turn off the ignition if the ECS lamp is lit because the trouble codes can be lost.

If the ECS lamp is not lit, proceed to the D-Check procedure. If the ECS lamp is lit, perform the U-Check procedure.

**To perform a U-Check:**

1. If a hard code is present the LED on the ECM will be flashing the code. Gather these codes before proceeding.
2. On vehicles with ECM memory capability, continue with step 3. On vehicles without ECM memory capability, leave the engine running and skip to step 4.
3. On vehicles with ECM memory, turn the key off and connect the vehicle Read Memory connectors together (see "D-Check and Read Memory Connector Locations" on page 166). Some cars have black connectors, and some have clear connectors.
4. Identify the vehicle, connect the data cable, and confirm the identification. On vehicles with ECM memory capability, turn the key on and leave the engine off.
5. Select **Code Functions > Auto Code Read** from the Main Menu and follow the connection instructions earlier in this chapter.
6. At this point, the scan tool reads and displays any codes stored in the ECM memory.
7. Separate the Read Memory connectors.
8. Proceed to the D-Check procedure for the test vehicle.

1983–89 ECC D-Check

Use this D-Check procedure for all 1983–89 vehicles with an electronically controlled carburetor (ECC), except Justy. If the ECS lamp is lit, perform the ECS check (U-Check) before doing this D-Check.

**To perform a D-Check:**

1. Connect the scan tool data cable to the vehicle.
2. Start the engine and warm it to normal operating temperature.
3. Stop the engine and connect the green D-Check connectors (see "D-Check and Read Memory Connector Locations" on page 166) together.
4. Turn the ignition on, but do not start the engine.
The ECS lamp should light, and the ECM transmits a specific vehicle identification code. The scan tool recognizes these codes.
5. Start the engine.
The ECS lamp should go off.
6. Drive the vehicle at least 60 feet and let the engine idle for at least 20 seconds. (This may be done carefully on a service rack, if necessary.)
7. Snap the throttle fully open two times.
8. Run the engine at 2500 RPM until the ECS lamp lights.
A flashing lamp indicates the system is OK. A continuously lit lamp indicates trouble codes are present. The scan tool reads these codes.

9. Select **Code Functions > Auto Code Read** from the Main Menu and follow the connection instructions earlier in this chapter.
10. Separate the D-Check connectors.

Pre-1987 MPI D-Check

Use this D-Check procedure for 1983–86 vehicles with multipoint injection (MPI). If the ECS lamp is lit, perform the ECS check (U-Check) first.



To perform a D-Check:

1. Connect the scan tool data cable to the vehicle.
2. Connect the two green D-Check connectors (see “D-Check and Read Memory Connector Locations” on page 166) together.
3. Turn the ignition on but do not start the engine.
The ECS lamp on the instrument panel should light.
4. Start the engine.
The ECS lamp should go off.
5. Run the engine at idle for 1 minute; then snap the throttle fully open 5 times.
6. Briefly race the engine to activate the pressure switch test; then drive at a speed above 6 mph. (This may be done carefully on a service rack, if necessary.)
7. Run the engine at 2500 RPM until the ECS lamp lights.
A flashing lamp means the system is OK. A continuously lit lamp means trouble codes are present. The scan tool reads the codes.
8. Select **Code Functions > Auto Code Read** from the Main Menu and follow the connection instructions earlier in this chapter.
9. Repeat this procedure until no trouble codes are found.
10. Separate the D-Check connectors.

1987 Justy EFC D-Check

Use this D-Check procedure for 1987 Justy vehicles with an electronic feedback carburetor (EFC). If the ECS lamp is lit, perform the ECS check (U-Check) before doing this D-Check.



To perform a D-Check:

1. Connect the scan tool data cable to the vehicle.
2. Start the engine and warm it to normal operating temperature.
3. Stop the engine and connect the green D-Check connectors (see “D-Check and Read Memory Connector Locations” on page 166) together.
4. Turn the ignition on but do not start the engine.
The ECS lamp should light and the ECM transmits specific vehicle identification codes. The scan tool recognizes these codes.
5. Start the engine and the ECS lamp should go off.
6. Drive the vehicle at least 60 feet and let the engine idle for at least 20 seconds. (This may be done carefully on a service rack, if necessary.)

7. Switch the parking lamps, rear window defogger, and heater fan on and then off.
A flashing lamp indicates the system is OK. A continuously lit lamp indicates trouble codes are present. The scan tool reads these codes.
8. Select **Code Functions > Auto Code Read** from the Main Menu and follow the connection instructions earlier in this chapter.
9. Separate the D-Check connectors.

1988–90 Justy EFC or 1990–91 MPI D-Check

Use this D-Check procedure for 1988–90 Justy models with an electronic feedback carburetor (EFC), and 1990–91 Justy models with MPI. If the ECS lamp is lit, perform the ECS check (U-Check) before doing this D-Check.



To perform a D-Check:

1. Connect the scan tool data cable to the vehicle.
2. Start the engine and warm it to normal operating temperature.
3. Stop the engine and connect the green D-Check connectors (see “D-Check and Read Memory Connector Locations” on page 166) together.
4. Turn the ignition but do not start the engine.
The ECS lamp should light and the ECM transmits specific vehicle identification codes. The scan tool recognizes these codes. (Read codes visually on the ECM LED for 1990 Justy MPI; see “Code Type 08a” on page 177.)
5. Depress the accelerator to the floor, then slowly release it.
6. Start the engine.
The ECS lamp should go off.
7. With a manual transmission, depress the clutch and then release it.
8. Switch the parking lamps, rear window defogger, and heater fan on and then off.
9. Drive the vehicle at 30 mph above 2500 RPM. (This may be done carefully on a service rack, if necessary.)
10. Run the engine at 2700 RPM until the ECS lamp turns on.
A flashing lamp indicates the system is OK. A continuously lit lamp indicates trouble codes are present. The scan tool reads these codes. (Read codes visually on ECM LED for 1990 Justy MPI; see “Code Type 08a” on page 177.)
11. Select **Code Functions > Auto Code Read** from the Main Menu and follow the connection instructions earlier in this chapter.
12. After verifying the repair, repeat the D-Check with the Read Memory connectors connected to clear codes from ECM memory.
13. Separate the D-Check and Read Memory connectors.

1986–94 SPI and 1987–92 MPI D-Check (except Justy)

Use this D-Check procedure for 1986–94 single-point injection (SPI) vehicles except Justy and 1987–92 multipoint injection (MPI) vehicles. If the ECS lamp is lit, perform the ECS check (U-Check) before doing this D-Check.

**To perform a D-Check:**

1. Connect the scan tool data cable to the vehicle.
2. Start the engine and warm it to normal operating temperature.
3. Stop the engine and connect the green D-Check connectors (see “D-Check and Read Memory Connector Locations” on page 166) together.
4. Turn the ignition on but do not start the engine.
The check engine lamp (CEL) lamp should light.
5. Depress the accelerator completely, release it halfway, hold it for two seconds, and then release it completely.
6. Start the engine.
The CEL lamp should go off.
7. Drive the vehicle at least 7 mph for at least one minute. (This may be done carefully on a service rack, if necessary.)
8. Warm the engine at 2000 RPM until the ECS lamp turns on.
A flashing lamp indicates the system is OK. A continuously lit lamp indicates codes are present. The scan tool reads these codes.
9. Select **Code Functions > Auto Code Read** from the Main Menu and follow the connection instructions earlier in this chapter.
10. After verifying the repair, repeat the D-Check with the Read Memory connectors connected to clear codes from ECM memory.
11. Separate the D-Check and Read Memory connectors.

15.1.6 Code Type 08

Subaru uses five types of code patterns:

- “Code Type 08 (Straight Count)” for ABS systems
- “Code Type 08a” for engines, 4EAT (version 2) and ECVT transmissions, and airbags
- “Code Type 08b” for 4EAT (version 1) transmissions
- “Code Type 08c” for All systems
- “Code Type 08d” for ABS systems

Code Type 08 (Straight Count)

Code Type 08 (Straight Count) codes are read from the ABS LED after the ABS instrument panel light has illuminated on 1990 Legacy Touring Wagon, 1990–1992 Sedan and 1992–1997 SVX. Only current or active codes can be read. No memory codes are available. Codes are read by counting flashes on the ABS LED under the right front seat. If the ignition switch is turned off, the codes will be lost. The vehicle must then be driven following the step-by-step procedures to cause them to reset.

Code Type 08 (Straight Count) flashes the LED in a straight forward counting sequence. the code number digits display as 0.4 to 1.0 second pulses with 0.4 to 1.0 seconds between each pulse. A pause of 5.2 to 13 seconds indicates the end of flashes to count and the code will be repeated again. Only one code is displayed at a time. After repairs, perform a test drive and check for any additional codes that need attention.

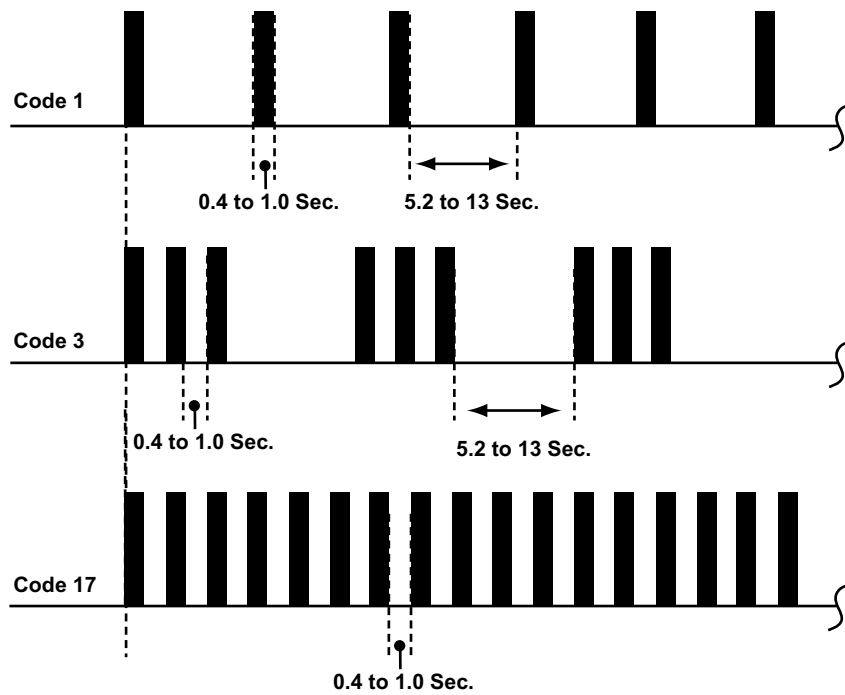

Figure 15-44 Subaru Code Type 08 (Straight Count)

Table 15-10 Subaru Code Type 08 (Straight Count)

Pattern:	A straight counting of the number of flashes
Read codes on:	ABS LED under right front seat
Start codes by:	Counting flashes of LED after the ABS lamp has illuminated.
When done:	Clear codes occurs every time the ignition switch is turned off.

Code Type 08a

Type 08a engine codes are read from the check engine light on 1990–94 Legacy and Impreza and on 1992–95 SVX. Two types of codes can be read: memory codes and active codes. Codes are read by hooking test connectors together and following a step-by-step procedure.

Code Type 08a flashes a two-digit (long/short) code on the check engine lamp (Figure 15-45). Each 10s digit displays as 1.2-second pulses with 0.3 seconds between each pulse. Each 1s digit displays as 0.2-second pulses with a 0.3-second pause between each digit. With multiple codes, there is a 1.8-second pause between codes.

Additional information for testing other systems that use this code type can be found in each system’s testing section.

Code Type 08c

The ABS light signals a “Start Code” consisting of a 1.2-second flash and 0.3 flash separated by a 0.3 second pause (Figure 15-47). Then the light flashes any stored codes. Each code consists of long and short flashes separated by a 0.3 second pause.

The total number of long flashes represent the 10s or tenth-place digit and the total number of short flashes represents the 1s or first-place digit. A 1.0 second pause follows each code. After all codes flash, the Start Code repeats. This sequence repeats for up to five minutes.

Additional information for testing other systems that use this code type can be found in each system’s testing section.

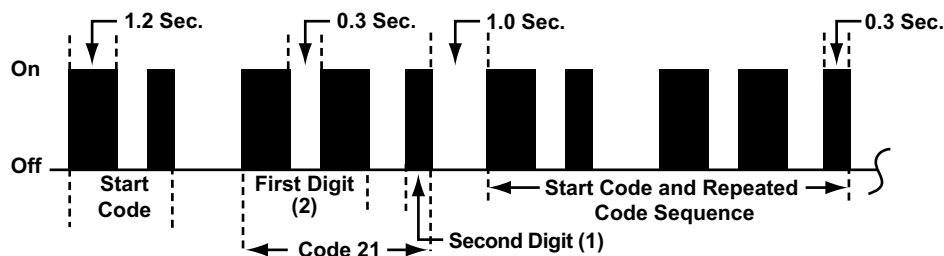

Figure 15-47 Subaru Code Type 08c

Table 15-13 Subaru Code Type 08c

Pattern:	Long and short
Read codes on:	ABS, airbag (SRS) Warning Light on instrument panel
Start codes by:	Follow the appropriate Subaru procedure.
When done:	Clear codes according to the Subaru procedure.

Code Type 08d

The ABS or TCS light signals a “Start Code” consisting of a 1.5 second flash, a 2.0 second pause, a 1.2 second flash, a 0.6 second pause and a 0.3 second flash. After another 1.2 second pause, the light then flashes any stored codes. Each code consists of long (1.2 second) flashes and short (0.3 second) flashes separated by a 0.3 second pause.

The total number of long flashes represent the 10s or tenth-place digit and the total number of short flashes represents the 1s or first-place digit. A 0.6 second pause separates the 10s digit(s) from the 1s digit(s). A 1.2 second pause follows each code. After all codes flash, the Start Code repeats. This sequence repeats for up to five minutes.

Additional information for testing other systems that use this code type can be found in each system’s section.

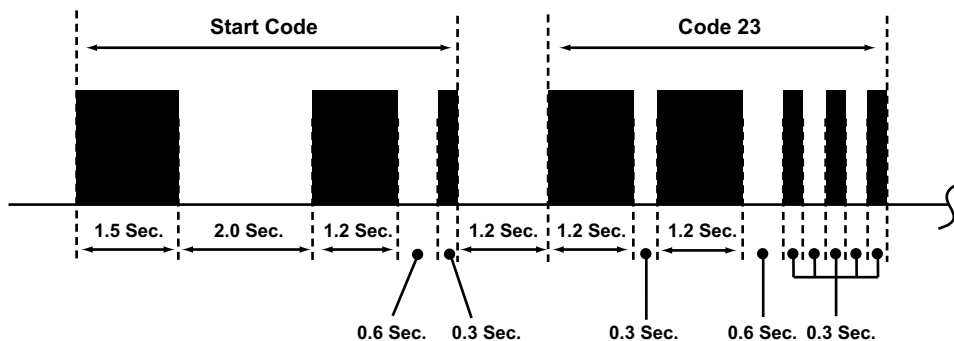

Figure 15-48 Subaru Code Type 08d

Table 15-14 Subaru Code Type 08d

Pattern:	Long and Short
Read codes on:	ABS or TCS light on instrument panel
Start codes by:	Follow the appropriate Subaru procedure.
When done:	Clear codes according to the Subaru procedure.

15.2 Testing Transmission Systems

The following sections include information for testing Subaru transmission systems. Subaru transmission testing includes the following:

- “Transmission Code Reading” on page 180
- “1987–92 4EAT Transmission (Version 1)” on page 181
- “1990–96 4EAT Transmission (Version 2)” on page 181
- “1990-96 4EAT Transmission (Version 2) History Codes” on page 182
- “1989-94 Justy ECVT Transmission” on page 183
- “1996-06 Subaru Models with an OBD-II 16-pin Connector” on page 184

15.2.1 Transmission Code Reading

If you select Transmission from the System Selection menu after identifying a vehicle, the scan tool gives you instructions for applying power or connecting to the OBD-II 16-pin connector where applicable. Automatic code gathering is *not* available on Subaru transmissions before 1984 or on Subaru models with an OBD-II 16-pin connector with no other specified Check connectors used to gather transmission codes. The How To Get Codes selection from the Code Functions menu displays manual code gathering instructions (see “How to Get Codes” on page 11).

Subaru uses two different code types for transmission codes. Detailed information for these code types can be found in the section “Code Type 08” on page 176:

- “Code Type 08a” for 1990–94 4EAT (version 2) and all Justy ECVT transmissions.
- “Code Type 08b” for 1987–91 4EAT (version 1) transmissions.
- Generic Powertrain codes for 1996-2006 models with no other diagnostic routines specified by the manufacturer.

The scan tool displays the code type for the specific vehicle you are testing. The transmission control system is placed in the diagnostic mode by performing vehicle-specific routines. These routines consist of a series of ignition cycles, throttle movements, and gear selections.

15.2.2 1987–92 4EAT Transmission (Version 1)

Use this procedure to test the 4EAT transmission in 1987–1991 XT and XT6, and 1987–1992 4WD Loyale Turbo MPFI.



To determine if any codes are present:

- Turn the ignition on (engine off).

Codes are present if the Power lamp flashes four times following the 2 second bulb check. If the lamp remains on, there is a problem in the lamp circuit or with the control module. If the lamp remains off after the 2 second lamp check, no codes are present.



To place the TCM in diagnostic, or code-display, mode:

1. Start and warm the engine to operating temperature.
2. Switch the ignition off and set the 1st gear Hold switch to off. The Hold switch is on center console, adjacent to gear selector.
3. Place the gear selector in Park and start the engine.
The Power lamp on the instrument panel should light for about 2 seconds.
4. Switch the ignition off, place the gear selector in Drive, and switch the 1st gear Hold switch on.
5. Switch the ignition on without starting the engine, wait at least 2 seconds, and then move the gear selector to 3rd.
6. Switch the 1st gear Hold switch off, move the gear selector to 2nd, and then switch the 1st gear Hold switch on.
7. Fully depress and release the throttle to begin manual code gathering.
The Power lamp flashes Code Type 8b (Figure 15-46).

15.2.3 1990–96 4EAT Transmission (Version 2)

Use this procedure to test the 4EAT transmission in 1990–1995 Legacy, 1992–1996 SVX, and 1993–95 Impreza.



To determine if any current codes are present:

- Turn the ignition on (engine off).

Current codes are present if the Power lamp flashes four times after the 2 second bulb check. If the lamp remains on, there is a problem in the lamp circuit or with the control module. If the lamp remains off after the 2 second lamp check, no current codes are present; however, history codes may still be in memory (See “1990-96 4EAT Transmission (Version 2) History Codes”).

**To place the TCM in diagnostic, code-display, mode:**

1. Start and warm the engine to operating temperature.
2. Drive the vehicle at speeds above 12 mph.
3. Switch the ignition off and set the Manual switch to off. The Manual switch is on center console, adjacent to gear selector.
4. Place the gear selector in Park and start the engine.
The Power lamp on the instrument panel should light for about 2 seconds.
5. Switch the ignition off, place the gear selector in Drive, and turn the Manual switch on.
6. Switch the ignition on without starting the engine, wait at least 2 seconds, and then move the gear selector to 3rd.
7. Switch the Manual switch off, move the gear selector to 2nd, and then switch the Manual switch on.
8. Move the gear selector to 1st and switch the Manual switch off.
9. Fully depress and release the throttle to begin manual codes.

If no codes are present, the Power lamp flashes evenly 2 times per second. If codes are present, the lamp flashes Code Type 8a (long/short) (Figure 15-45 on page 178). A TCM that flashes the 2 times per second pass code may still have history codes in memory.

15.2.4 1990-96 4EAT Transmission (Version 2) History Codes

Use the following procedure to check the 4EAT transmission for history codes on 1990–95 Legacy, 1992–96 SVX, and 1993–95 Impreza models. Be aware, a vehicle that flashes the Power lamp twice per second (pass code) may still have history codes stored in memory.

**To place the TCM in the diagnostic, history code display mode:**

1. Start and warm the engine to operating temperature.
2. Drive the vehicle above 12 mph.
3. Switch the ignition off and set the Manual switch to off. The Manual switch is on center console, adjacent to gear selector.
4. Place the gear selector in Park and start the engine.
The instrument panel Power lamp should light for about 2 seconds.
5. Switch the ignition off, place the gear selector in 1st, and set the Manual switch to on.
6. Place the gear selector in 2nd, and set the Manual switch to off.
7. Place the gear selector in 3rd, and set the Manual switch to on.
8. Place the gear selector in Drive, and set the Manual switch to off.
9. Fully depress and release the throttle to begin manual history codes.

If no codes are present, the Power lamp flashes evenly 2 times per second. If codes are present, the lamp flashes Code Type 8a (long/short) (Figure 15-45 on page 178).

15.2.5 1989-94 Justy ECVT Transmission

Use this procedure to test the 1989–94 Justy electronic constant velocity transmission (ECVT). On ECVT models you must perform the memory code diagnostic check before checking for current codes (D-Check). Failure to do so results in the loss of memory codes.



To place TCM in diagnostic, memory-code display-mode:

1. With the ignition off, mate the check mode connectors (white, single-pin connector near ECVT ECM).
2. Place the gear selector in neutral and switch the ignition on (engine off).
3. On 2WD models, the ECVT lamp on the instrument panel should light.
4. On 4WD models, the Clutch Temp lamp should light.
5. While holding the throttle fully depressed, move the gear selector from neutral-to-reverse, and then back to neutral.
6. Release the throttle and start the engine. If there are no codes are present, the ECVT (2WD) or Clutch Temp (4WD) lamp flashes evenly twice per second. If codes are present, the lamp flashes Code Type 8a (long/short) (Figure 15-45 on page 178).

IMPORTANT:

Perform the following procedure only in an area where the vehicle can safely coast to a stop from 25 mph, without applying the brakes.



To perform the Justy D-Check for current codes, proceed as follows:

1. With the ignition switched off, mate the check mode connectors (white, single-pin connector near ECVT ECM).
2. Start and warm the engine to operating temperature.
3. Switch the ignition off and place the shift lever in Park.
4. Switch the ignition on (engine off).
5. On 2WD models, the ECVT lamp on the instrument panel should light.
6. On 4WD models, the Clutch Temp lamp should light.
7. Start the engine.
The ECVT or Clutch Temp lamp flashes the ID number of the TCM using a Code Type 8a (long/short) pattern.
8. With the engine running, firmly depress the brake pedal and move the shift lever in this sequence; Park-to-Reverse-to-Neutral-to-Drive-to-Ds-to-Drive.
9. Perform full throttle acceleration to 25 mph and then let the vehicle coast to a stop without applying the brakes.
10. Press and release the brake pedal three times.
11. If no codes are present, the ECVT (2WD) or Clutch Temp (4WD) lamp flashes evenly, twice per second.
12. If codes are present, the lamp flashes Code Type 8a (long/short) (“Subaru Code Type 08a” on page 178, Figure 15-45).

15.2.6 1996-06 Subaru Models with an OBD-II 16-pin Connector

1996-2006 Subaru models with an OBD-II 16-pin connector do not support any other specific diagnostic routines. Refer to the section “Testing Engine Systems” on page 143 for OBD-II 16-pin connector locations. Codes displayed are OBD-II Generic Powertrain codes.

15.3 Testing ABS Systems

The following sections include information for testing Subaru antilock brake systems. Subaru ABS testing includes the following:

- ABS Code Information
- ABS Code Types
- ABS Code Reading and Connector Locations

15.3.1 ABS Code Information

If you select ABS from the System Selection menu after identifying a 1990–2004 model year vehicle, the scan tool gives you instructions for applying power. If you select ABS from the System Selection menu after identifying a 2005–2006 model year vehicle, the scan tool gives you instructions for connecting to the OBD-II 16-pin connector.

1990–2004 Subaru ABS systems use manual code gathering only. The How To Get Codes selection from the Code Functions menu displays manual code gathering instructions (see “How to Get Codes” on page 11).

The ABS system is placed in the diagnostic mode by performing vehicle-specific diagnostic routines. These routines consist of driving the vehicle over a specified speed, driving for a specified time or connecting a grounded jumper to a specific pin of the diagnostic connector.

15.3.2 ABS Code Types

Detailed information for reading code types can be found in “Code Type 08” at the end of the “Testing Engine Systems”.

Subaru ABS systems use the following code types:

- “Code Type 08 (Straight Count)” on page 176 for ABS systems without memory
- “Code Type 08c” on page 179 for ABS systems with memory
- “Code Type 08d” on page 179 for ABS systems with TCS
- Manufacturer Specific Codes for 2005–2006 Subaru ABS systems

ABS Code Types by Model

- 1990 Legacy Touring Wagon—Code Type 08 (Straight Count) (Figure 15-44).
- 1990–92 Legacy Wagon—Code Type 08 (Straight Count) (Figure 15-44).

- 1990–92 Sedan 2.2L—Code Type 08 (Straight Count) (Figure 15-44).
- 1992–97 SVX—Code Type 08 (Straight Count) (Figure 15-44).
- 1993–04 All Others—Code Type 08c (Figure 15-47).
- 1995–97 Legacy Sedan with TCS—Code Type 08d (Figure 15-48).
- 1995–97 Legacy Outback with TCS—Code Type 08d (Figure 15-48).
- 1995–97 Legacy Wagon with TCS—Code Type 08d (Figure 15-48).
- 2005–06 All Subaru models display codes and data with the scan tool.

15.3.3 ABS Code Reading and Connector Locations

- 1990–1992 Legacy/Outback, Sedan and Wagon (Figure 15-49)
- 1992–1997 SVX (Figure 15-49)
- 1993–1994 Legacy/Outback, Sedan and Wagon (Figure 15-50)
- 1995–1996 Legacy/Outback, Sedan and Wagon w/o TCS (Figure 15-51)
- 1995–1996 Legacy/Outback, Sedan and Wagon with TCS (Figure 15-51)
- 1993–1996 Impreza Coupe, Sedan and Wagon w/o TCS (Figure 15-51)
- 1997 (early) Legacy/Outback, Sedan and Wagon (Figure 15-53)
- 1997 (late)–1999 Legacy/Outback, Sedan and Wagon (Figure 15-51)
- 1998–2001 Impreza Coupe, Sedan and Wagon (Figure 15-51)
- 2001 Forester (Figure 15-51)
- 2000–2004 Legacy/Outback, Sedan and Wagon (Figure 15-54)
- 2003–2004 Baja (Figure 15-51)
- 2005–2006 All Subaru Models ((Figure 15-55)

1990–92 Legacy/Outback, Sedan and Wagon 1992–97 SVX



To retrieve trouble codes:

1. Drive the vehicle at speeds greater than 19mph (30kph) for at least one minute before attempting to access the self-diagnostic program.
2. Do not switch the ignition off after driving.
3. The ABS lamp on the instrument panel turns on when the self-diagnostic program senses a problem.
4. About 5 to 12 seconds after the instrument panel lamp turns on, the ABS trouble codes display by flashing an LED.
5. The LED is located under the right-front seat (Figure 15-49). See “Subaru Code Type 08 (Straight Count)” on page 177 for reading codes from the flashing LED.

The following condition apply to testing these vehicles:

- Both the instrument panel lamp and LED remain active as long as the ignition is on.
- There is no memory, so trouble codes are lost if the key is switched off.
- Only one code displays at a time, repair and road test until all problems are corrected.
- If the LED does not flash codes and the panel lamp is on, check the power supply circuit.

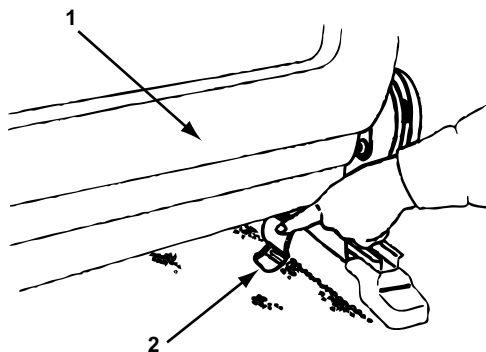

1— Right front seat

2— LED

Figure 15-49 1990-92 Legacy and 1992-97 SVX ABS LED location

1993-94 Legacy/Outback, Sedan and Wagon



To retrieve trouble codes:

1. Remove the lower trim panel from the driver side front pillar or kick-panel.
2. Next, switch the ignition on.
3. Ground the ABS Check connector terminal L (Figure 15-50).
4. Read the trouble codes on the ABS warning lamp (Code Type 08c Figure 15-47).

The following condition apply to testing these vehicles:

- Code 11 displays first, then other stored codes beginning with the most recent.
- The code display repeats for up to five minutes.
- If there are no codes in memory, only code 11 displays.



To clear code memory:

1. Disconnect the ABS Check connector terminal L from ground (Figure 15-50).
2. Connect terminal L to ground for at least 0.05 second and then disconnect it.
3. Repeat step 2 an additional two times (3 times total) within twelve seconds

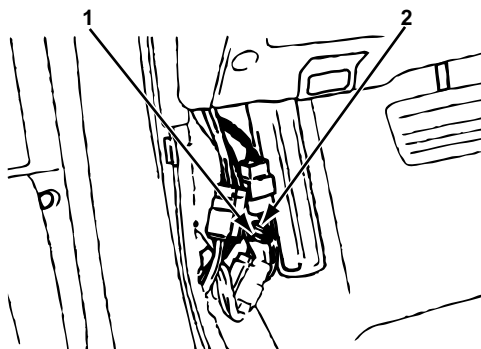

1— Terminal K

2— Terminal L

Figure 15-50 1993-94 Legacy ABS Check connector location

1995–96 Legacy/Outback, Sedan and Wagon w/o TCS
1997 (late)–99 Legacy/Outback, Sedan and Wagon
1998–04 Impreza Coupe, Sedan and Wagon
2001–04 Forester
2003–04 Baja



To retrieve trouble codes:

1. Locate the ABS diagnostic connector and diagnostic terminals near the heater assembly on the driver side (Figure 15-51).
2. Switch the ignition off.
3. Connect a diagnosis terminal to the diagnosis connector terminal 6.
4. Switch the ignition on.
5. Read the trouble codes on the TCS warning lamp (Code Type 08c – Figure 15-47)
The following condition apply to testing these vehicles:
 - Code 11 displays first, then the stored codes display in order, beginning with the most recent stored codes.
 - The code display repeats for up to five minutes.
 - If there are no codes in memory, only code 11 displays.



To clear code memory:

1. Disconnect the diagnosis terminal from the diagnosis connector terminal 6 (Figure 15-51).
2. Connect the diagnosis terminal to the diagnosis connector terminal 6 for at least 0.2 second and then disconnect it.
3. Repeat step 2 an additional two times (3 times total) within twelve seconds.

1995–96 Legacy/Outback, Sedan and Wagon with TCS



To retrieve trouble codes:

1. Locate the ABS diagnostic connector and diagnostic terminals near the heater assembly on the driver side (Figure 15-51).
2. Switch the ignition off.
3. Connect a diagnosis terminal to the diagnosis connector terminal 4.
4. Switch the ignition on.
5. Read the trouble codes on the TCS warning lamp (Code Type 08d – Figure 15-48)
The following condition apply to testing these vehicles:
 - Code 11 displays first, then the stored codes display in order, beginning with the most recent stored codes.
 - If there are no codes in memory, only code 11 displays.



To clear code memory:

1. Disconnect the diagnosis terminal from the diagnosis connector terminal 4 (Figure 15-51).
2. Connect the diagnosis terminal to the diagnosis connector terminal 4 for at least 0.15 second and then disconnect it.
3. Repeat step 2 an additional two times (3 times total) within twelve seconds.

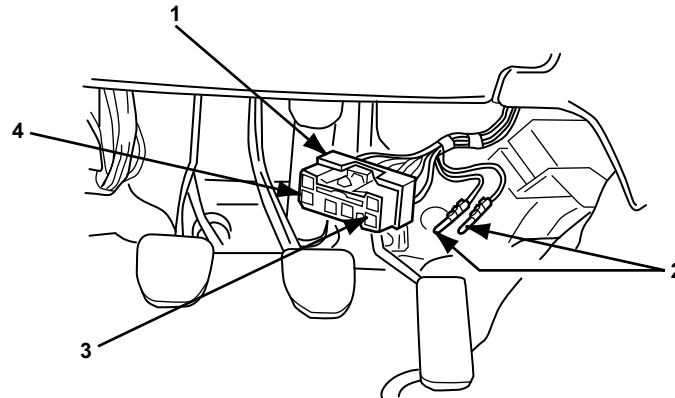

- 1— Diagnosis connector
- 2— Diagnosis terminals
- 3— Pin 6 (L Terminal)
- 4— Pin 3 (K Terminal)
- 5— Pin 4 (with TCS)

Figure 15-51 1995-99 Legacy, 1998-04 Impreza, 2001-04 Forester and 2003-04 Baja ABS Diagnostic Connector Location

1993–96 Impreza Coupe, Sedan and Wagon



To retrieve trouble codes:

1. Locate the ABS diagnostic connector under the dash near the steering column (Figure 15-52).
2. Switch the ignition off.
3. Ground the ABS Check connector terminal L.
4. Switch the ignition on.
5. Read the trouble codes on the ABS warning lamp (Code Type 08c - Figure 15-47).

The following condition apply to testing these vehicles:

- Code 11 displays first, then the stored codes display in order, beginning with the most recent stored codes.
- The code display repeats for up to five minutes.
- If there are no codes in memory, only code 11 displays.



To clear code memory:

1. Disconnect the ground from the ABS Check connector terminal L.
2. Connect the ground to the ABS Check connector terminal L for at least 0.05 second and then disconnect it.
3. Repeat step 2 an additional two times (3 times total) within twelve seconds.

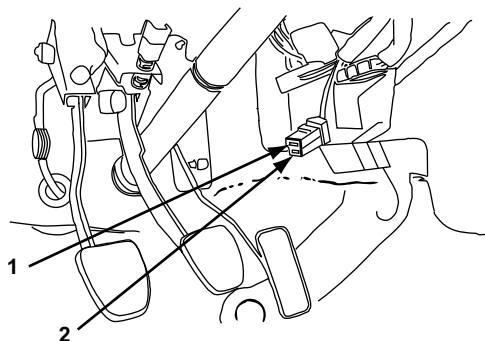

- 1— Terminal L
2— Terminal K

Figure 15-52 1993-96 Impreza ABS Check connector location

1997 Impreza Coupe, Sedan and Wagon 1997 (early) Legacy/Outback, Sedan and Wagon



To retrieve trouble codes:

1. Locate the ABS diagnosis connector and diagnosis terminals near the heater assembly on the driver side (Figure 15-53).
2. Switch the ignition off.
3. Connect a diagnosis terminal to the diagnosis connector terminal 2.
4. Switch the ignition on.
5. Read the trouble codes on the ABS warning lamp (Code Type 08c - Figure 15-47).

The following condition apply to testing these vehicles:

- Code 11 displays first, then the stored codes display in order, beginning with the most recent stored codes.
- The code display repeats for up to five minutes.

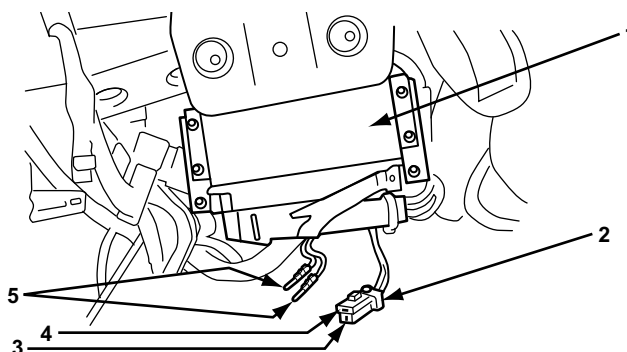

- 1— ABS control module
2— ABS diagnosis connector
3— Terminal 2
4— Terminal 1
5— Diagnosis terminal

Figure 15-53 1997 Impreza and 1997 (early) Legacy ABS diagnostic connector location



To clear code memory:

1. Disconnect the diagnosis terminal from diagnosis connector terminal 2.
2. Connect the diagnosis terminal to diagnosis connector terminal 2 for at least 0.05 second and then disconnect it.
3. Repeat step 2 an additional two times (3 times total) within twelve seconds.

2000–04 Legacy/Outback, Sedan and Wagon



To retrieve trouble codes:

1. Locate the ABS diagnosis connector and diagnosis terminals near the heater assembly on the driver side (Figure 15-54).
2. Switch the ignition off.
3. Connect a diagnosis terminal to the diagnosis connector terminal 8.
4. Switch the ignition on.
5. Read the trouble codes on the ABS warning lamp (Code Type 08c - Figure 15-47).

The following condition apply to testing these vehicles:

- Code 11 displays first, then the stored codes display in order, beginning with the most recent stored codes.
- The code display repeats for up to five minutes.



To clear code memory:

1. Disconnect the diagnosis terminal from diagnosis connector terminal 8.
2. Connect the diagnosis terminal to diagnosis connector terminal 8 for at least 0.2 second and then disconnect it.
3. Repeat step 2 an additional two times (3 times total) within twelve seconds.

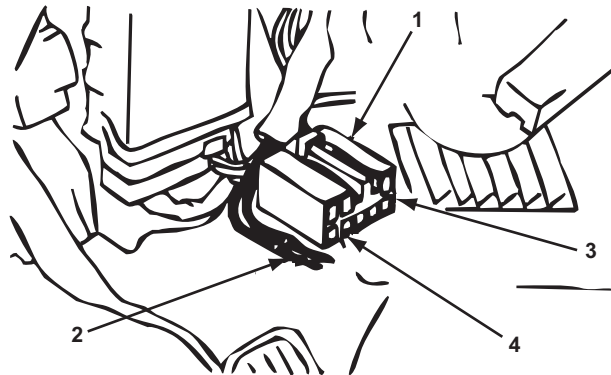

1— Diagnostic connector

2— Diagnosis terminal

3— 8 terminal

4— 5 terminal

Figure 15-54 2000–04 Legacy ABS diagnosis connector location

2005–06 All Subaru Models



To retrieve trouble codes:

1. Use the OBD-II adapter with the specified Personality Key™ device (Figure 15-55).
2. Select Codes Only from the Codes and Data menu and follow any instructions on the scan tool display.

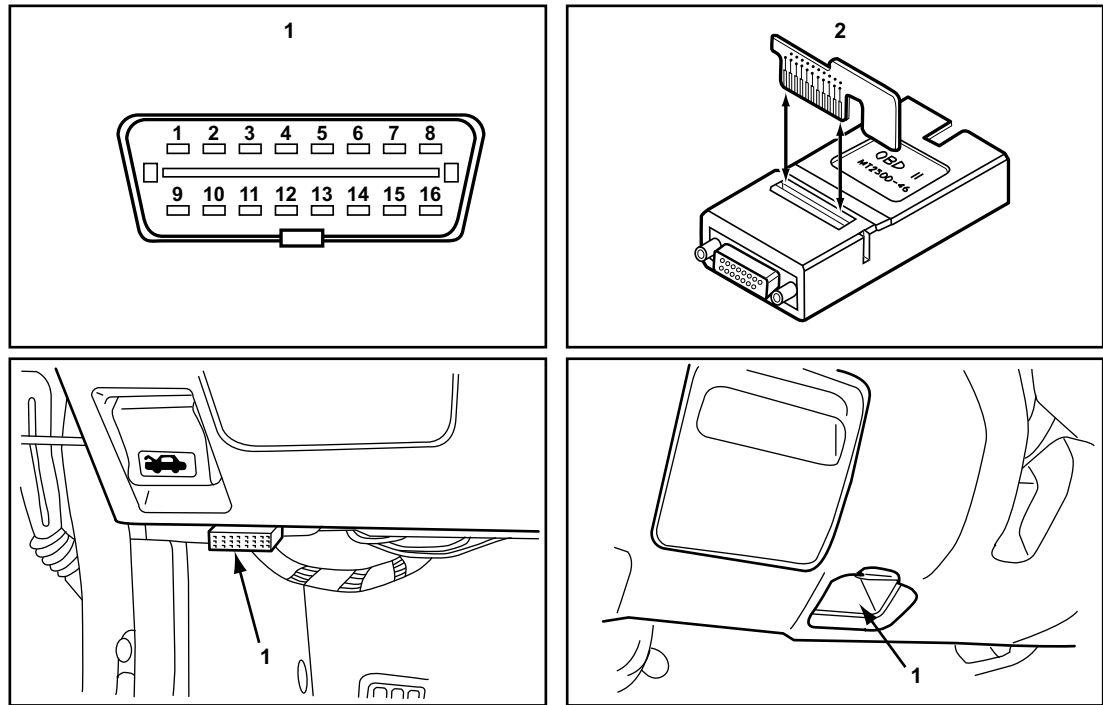

1— 16-pin DLC

2— OBD-II adapter and Personality Key™

Figure 15-55 16-Pin OBD-II connector and common locations



To clear code memory:

- Select Clear Codes from the Codes and Data menu and follow any instructions on the scan tool display.

15.4 Testing Airbag (SRS) Systems

The following sections include information for testing Subaru airbag supplemental restraint systems (SRS) systems. Subaru airbag (SRS) testing includes the following:

- Airbag (SRS) Code Information
- Airbag (SRS) Code Types
- Airbag (SRS) Code Reading and Connector Locations

15.4.1 Airbag (SRS) Code Information

If you select Airbag from the System Selection menu after identifying a 1992–2005 model year vehicle, except the 2005 Legacy/Outback Sedan or Wagon, the scan tool give you instructions for applying power. If you select Airbag from the System Selection menu after identifying a 2005 Legacy/Outback Sedan or Wagon, or any 2006 model except Baja, the scan tool gives you instructions for connecting to the OBD-II 16-pin connector.

All Subaru Airbag systems, except for 2005 Legacy/Outback Sedan or Wagon models, or any 2006 model except Baja, use manual code gathering only. The How To Get Codes selection from the Code Functions menu displays manual code gathering instructions (see “How to Get Codes” on page 11)

The Airbag system is placed in the diagnostic mode by performing vehicle specific diagnostic routines. These routines consist of connecting a grounded jumper or a diagnostic terminal to a specific pin of the diagnostic connector.

15.4.2 Airbag (SRS) Code Types

Detailed information for reading code types can be found in “Code Type 08” on page 176.

Subaru airbag (SRS) systems use the following code types:

- “Code Type 08 (Straight Count)” on page 176
- “Code Type 08c” on page 179 for most 1992–2005 Subaru airbag (SRS) systems
- Manufacturer Specific Codes for 2005 Subaru Legacy Outback Sedan and Wagon airbag (SRS) systems

15.4.3 Airbag (SRS) Code Reading and Connector Locations

- 1992–1997 SVX (Figure 15-56)
- 1995–1999 Legacy/Outback, Sedan and Wagon (Figure 15-57)
- 1998–2004 Impreza Coupe, Sedan and Wagon (Figure 15-57)
- 1998–2004 Forester and Wagon (Figure 15-57)
- 2000–2004 Legacy/Outback Sedan and Wagon (Figure 15-58)
- 2003–2006 Baja (Figure 15-58)
- 2005 Forester (Figure 15-59)
- 2005 Impreza (Figure 15-59)
- 2005 Legacy/Outback Sedan and Wagon (Figure 15-60)
- 2006 All Models except Baja (Figure 15-60)

1992–97 SVX



To retrieve 1992–1997 SVX airbag (SRS) codes:

1. With the key on and the engine off, install either diagnostic terminal into pin 9 of the airbag (SRS) diagnostic connector. The connector is located in the left kick panel area (Figure 15-56).
2. Read trouble codes on the SRS or airbag warning light (Code Type 08c, Figure 15-47).
3. Turn the key off and remove the diagnostic terminal from the diagnostic connector.



To clear code memory:

1. With the key on and the engine off, install either diagnostic terminal into pin 9 of the airbag (SRS) diagnostic connector (Figure 15-56).
2. When the SRS or airbag warning light is flashing trouble codes, install the other diagnostic terminal into pin 3 of the diagnostic connector for at least 3 seconds.
3. Codes are cleared when the SRS or airbag warning light resumes a normal flashing rate of 0.6 seconds On and 0.6 seconds Off.

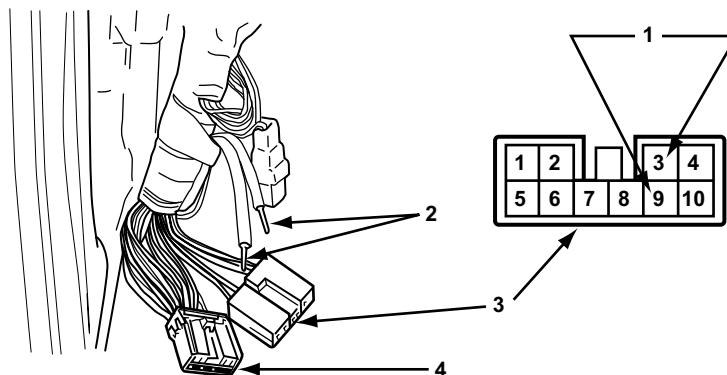

- 1— Pins 3 and 9
- 2— Diagnostic terminals
- 3— Airbag (SRS) Diagnostic connector (Black)
- 4— Subaru Select Monitor connector (yellow)

Figure 15-56 SVX airbag

1995–1999 Legacy/Outback, Sedan and Wagon 1998–2004 Impreza Coupe, Sedan and Wagon 1998–2004 Forester and Wagon



To retrieve 1998–2004 Impreza, 1995–1999 Legacy, and 1998–2004 Forester SRS codes:

1. With the key on and the engine off, install either diagnostic terminal into pin 1 or the airbag (SRS) diagnostic connector. The connector is located in the left lower dash panel area (Figure 15-57).
2. Read trouble codes on the SRS or airbag warning light (Code Type 08c, Figure 15-47).
3. Turn the key off and remove the diagnostic terminal from the diagnostic connector.



To clear 1998–2004 Impreza, 1995–1999 Legacy, and 1998–2004 Forester SRS codes:

1. With the key on and the engine off, install either diagnostic terminal into pin 1 of the airbag (SRS) diagnostic connector (Figure 15-56).
2. When the SRS or airbag warning light is flashing trouble codes, install the other diagnostic terminal into pin 2 of the diagnostic connector for at least 3 seconds.
3. Codes are cleared when the SRS or airbag warning light resumes a normal flashing rate of 0.6 seconds On and 0.6 seconds Off.

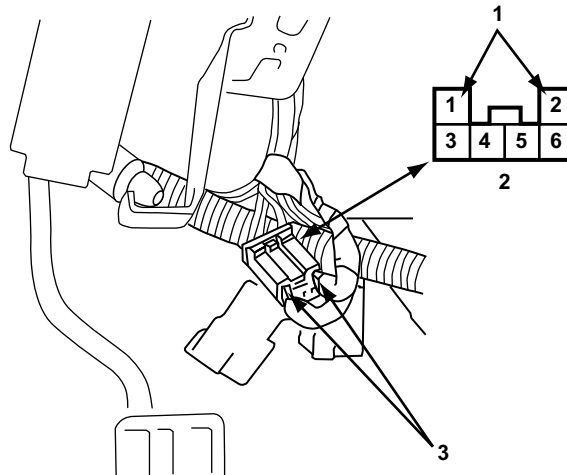

1— Pins 1 and 2

2— Airbag (SRS) Diagnostic connector

3— Diagnostic terminals

Figure 15-57 1998–2004 Impreza, 1995–99 Legacy, and 1998–2004 Forester Airbag (SRS) Diagnosis connector

**2003–2004 Legacy/Outback, Sedan and Wagon
2003–2006 Baja**



To retrieve 2000–2004 Legacy/Outback and 2003–2006 Baja SRS codes:

1. With the key on and the engine off, install either diagnostic terminal into pin 2 or the airbag (SRS) diagnostic connector. The connector is located in the left lower dash panel area (Figure 15-58).
2. Read the trouble codes on the SRS or airbag warning light (Code Type 08c - Figure 15-47).
3. Turn the key off and remove the diagnostic terminal from the diagnostic connector.



To clear 2000–2004 Legacy/Outback and 2003–2006 Baja SRS codes:

1. With the key on and the engine off, install either diagnostic terminal into pin 2 of the airbag (SRS) diagnostic connector (Figure 15-56).
2. When the SRS or airbag warning light is flashing trouble codes, install the other diagnostic terminal into pin 3 of the diagnostic connector for at least 3 seconds.
3. Codes are cleared when the SRS or airbag warning light resumes a normal flashing rate of 0.6 seconds On and 0.6 seconds Off.

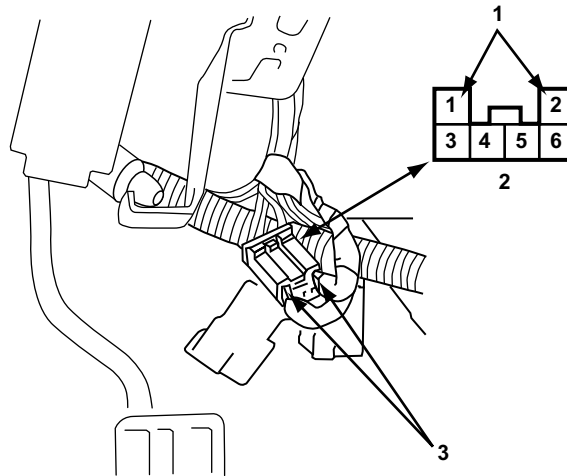

Figure 15-58 2000–04 Legacy and 2003–06 Baja Airbag (SRS) Diagnostic connector

- 1— Pins 2 and 3
- 2— Airbag (SRS) Diagnostic connector
- 3— Diagnostic terminals

2005 Forester 2005 Impreza Sedan and Wagon



To retrieve 2005 Impreza Sedan and Wagon and 2005 Forester SRS codes:

1. With the key on and the engine off, install either diagnostic terminal into pin 2 or the airbag (SRS) diagnostic connector. The connector is located in the left lower dash panel area (Figure 15-59).
2. Read the trouble codes on the SRS or airbag warning light (Code Type 08c - Figure 15-47).
3. Turn the key off and remove the diagnostic terminal from the diagnostic connector.



To clear 2005 Impreza Sedan and Wagon and 2005 Forester airbag (SRS) codes:

1. With the key on and the engine off, install either diagnostic terminal into pin 2 of the airbag (SRS) diagnostic connector (Figure 15-59).
2. When the SRS or airbag warning light is flashing trouble codes, install the other diagnostic terminal into pin 3 of the diagnostic connector for at least 3 seconds.
3. Codes are cleared when the SRS or airbag warning light resumes a normal flashing rate of 0.6 seconds On and 0.6 seconds Off.

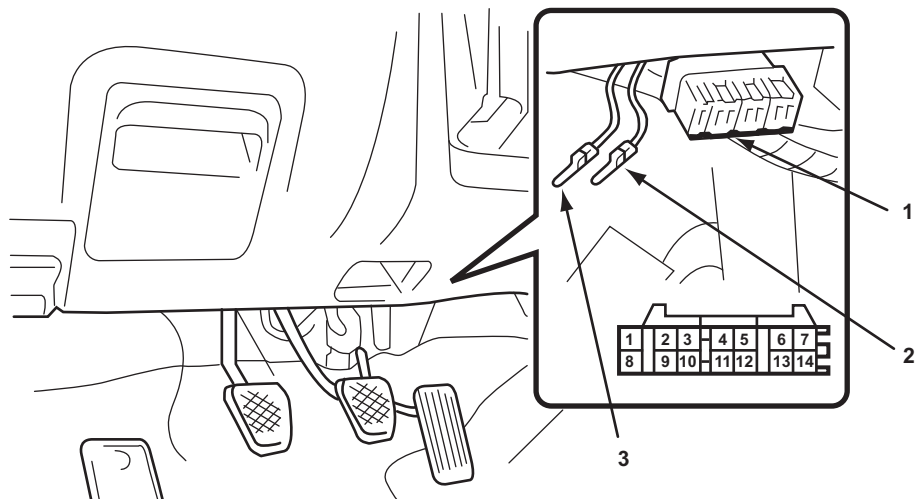

- 1— Airbag (SRS) Diagnostic Connector
- 2— Diagnostic terminal B
- 3— Diagnostic terminal A

Figure 15-59 2005 Forester and 2005 Impreza SRS Diagnostic connector (gray)

**2005 Legacy/Outback Sedan and Wagon
All 2006 Models except Baja**



To retrieve trouble codes:

1. Use the OBD-II adapter with the specified Personality Key™ device (Figure 15-60).
2. Select Codes Only from the Codes and Data menu and follow any instructions on the scan tool display.



To clear code memory:

- Select Clear Codes from the Codes and Data menu and follow any instructions on the scan tool display.

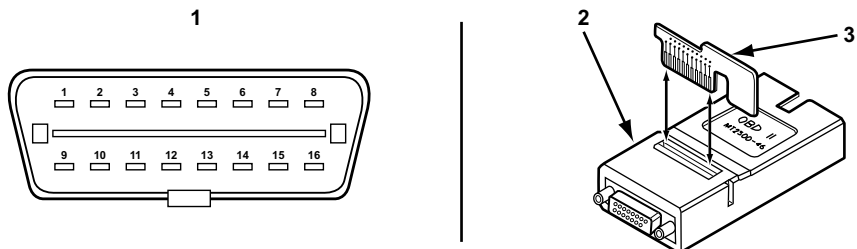

Figure 15-60 16-Pin OBD-II connector and common locations

- 1— 16-pin DLC
- 2— OBD-II adapter and Personality Key™

This chapter contains information for testing Toyota, Lexus and Scion vehicles. The following Toyota, Lexus and Scion systems may be available for testing:

- Engine
- Transmission
- Antilock Brake System (ABS)
- Supplemental Restraint System (SRS)

16.1 Identifying 1995 and Earlier Vehicles

Available engine types vary depending on the model and year. In most cases, you can find the engine type by locating the Vehicle Emission Control Information (VECI) sticker, or “emissions decal,” inside the engine compartment. If a VECI sticker is not available, engine type is sometimes noted on the vehicle nameplate (Figure 16-1), which may be:

- In the engine compartment on the bulkhead
- In either fender well area
- On a door or a door post

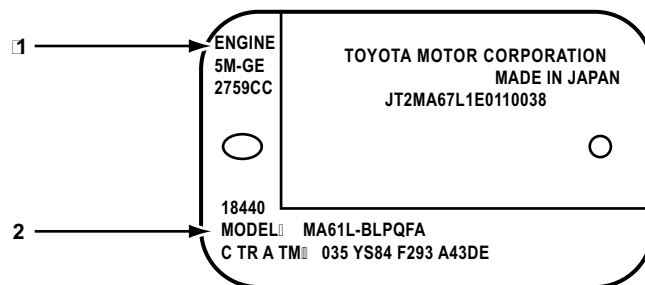

- 1— Engine type
2— Model number

Figure 16-1 Toyota vehicle nameplate

16.2 Testing Engine Systems

Toyota, Lexus, and Scion engine testing includes:

- “Code Reading Connectors and Locations” on page 198
- “Code Sensitivity—OBD-II and some Pre-OBD-II” on page 199
- “Data (No Codes)” on page 199
- “Manual Code Reading” on page 200
- “Actuator Tests” on page 200

16.2.1 Code Reading Connectors and Locations

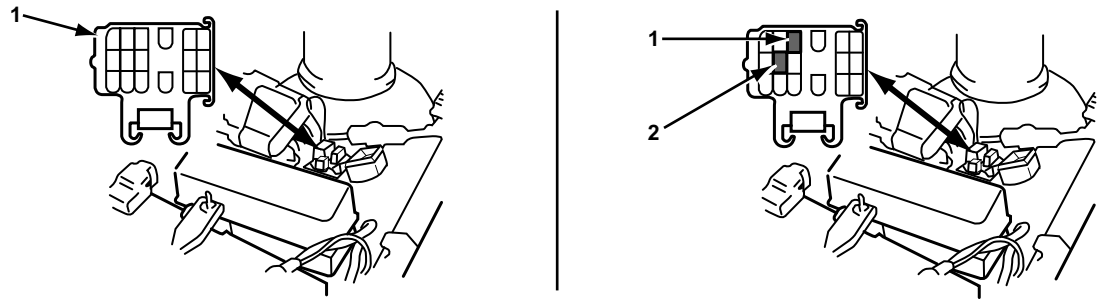

- 1— Use TOY-1 adapter
- 2— Optional: Jump E1 to T, T1, or TE1 to flash codes

Figure 16-2 Toyota/Lexus diagnostic connector requiring TOY-1 adapter

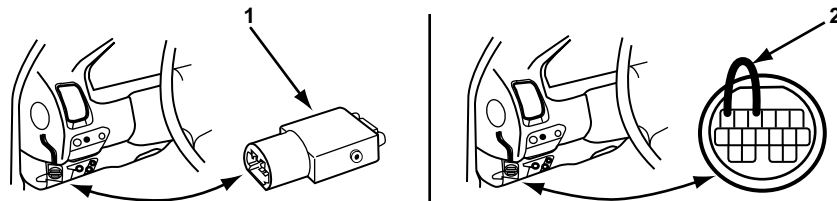

- 1— Use TOY-2 adapter
- 2— Optional: Jump E1 to TE1 to flash codes

Figure 16-3 Toyota/Lexus diagnostic connector requiring TOY-2 adapter

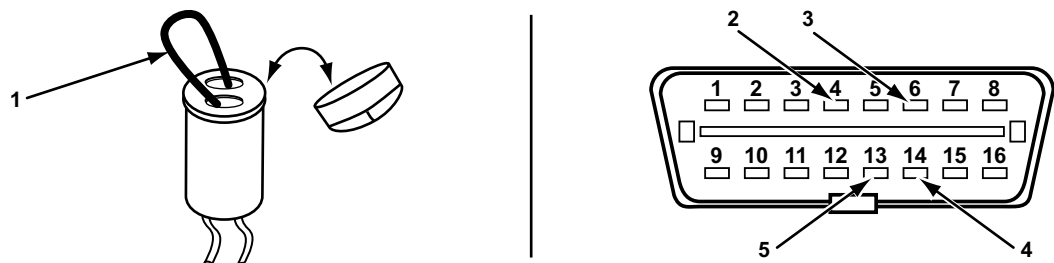

- 1— Jump T to E1 to flash codes
- 2— CG (Chassis Ground)
- 3— A/B
- 4— TS
- 5— TC

Figure 16-4 Toyota/Lexus diagnostic connectors—other

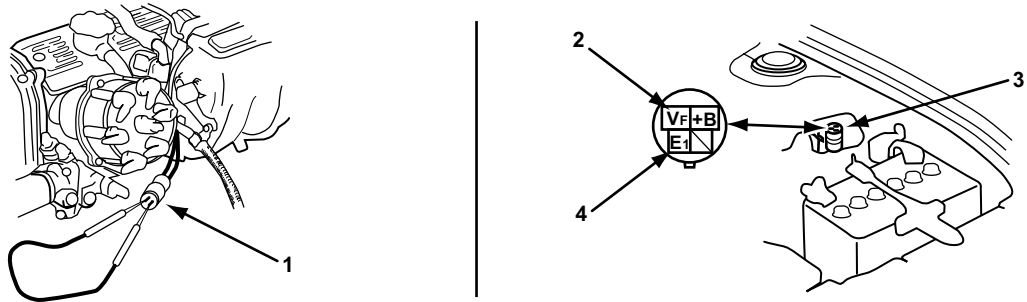

- 1— Check connector, short to activate code.
- 2— Blue
- 3— Service connector
- 4— Black

Figure 16-5 1983–84 Supra and Cressida connectors—use MULTI-1 adapter

16.2.2 Code Sensitivity—OBD-II and some Pre-OBD-II

Some Toyota and Lexus vehicles can be placed in a test mode where the ECM is more sensitive to diagnostic trouble codes (DTCs). The ECM stays in this mode until the ignition is turned off. For more details, see Fast-Track[®] Troubleshooter Reference TA044.



NOTE:

This mode will not work for evaporative emissions systems or misfire DTCs.

16.2.3 Data (No Codes)

The Data (No Codes) selection displays for vehicles that transmit PCM operating data to the scan tool. Use of this mode is very similar to the Codes and Data mode except that codes must be read separately using the Code Functions selection.

16.2.4 Manual Code Reading

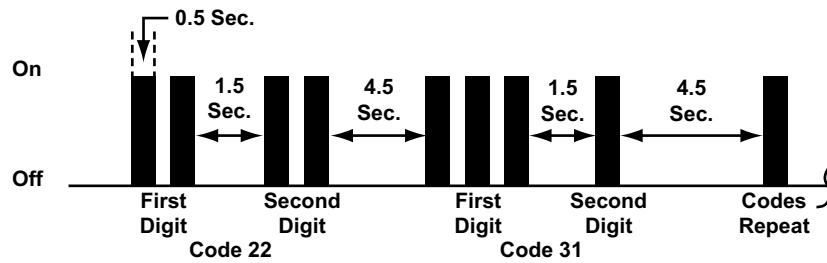

Figure 16-6 Code Type 09

Table 16-1 Toyota Code Type 09

Pattern:	10s and 1s; continuous flashing means system OK
Read codes on:	Check Engine lamp
Start codes by:	Connect the vehicle diagnostic connector terminals together and switch on the ignition.
When done:	Turn the ignition off, disconnect the connectors, then clear codes.

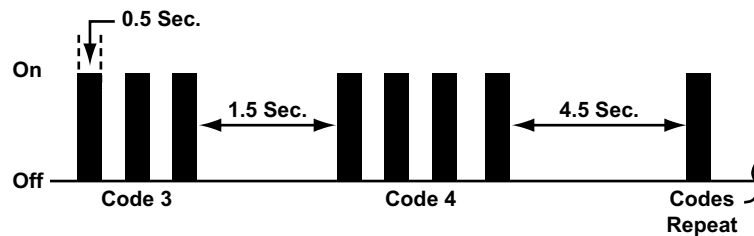

Figure 16-7 Code Type 10

Table 16-2 Toyota Code Type 10

Pattern:	Straight count
Read codes on:	Check Engine lamp
Start codes by:	Connect the vehicle diagnostic connector terminals together and switch on the ignition.
When done:	Turn the ignition off, disconnect the connectors, then clear codes.
Code 1 is pass code (system OK).	

16.2.5 Actuator Tests

Some Toyota, Lexus and Scion models have interactive bidirectional actuator tests. Though most actuator tests are best performed with the key on and engine running, the Fuel Pump and Fuel Pump Relay tests must be performed with the key and the engine off.

Most tests automatically display data parameters to help determine actuator or system performance. Some tests, like the Fuel Pump Test, do not display parameters. For these tests, monitor the selected actuator using a digital multimeter or listen for actuator activation.

For most tests, scrolling up and down switches the actuator on and off. Test completion does not mean that the actuator was activated.

IMPORTANT:

Do not enter any actuator test while driving unless the specific test requires it. Changes to ignition timing, fuel delivery, and other functions may affect operation and vehicle control.

The actuator tests may be grouped into the following test categories:

- EGR, evaporative emissions, secondary air systems
- Turbocharger and supercharger actuators
- Transmission solenoids
- Fuel delivery system
- Intake air delivery system
- Ignition timing
- Air conditioning system

**To conduct an EGR system test:**

1. Select **Actuator Tests > EGR System** from the Main Menu.
A test initiation screen displays.
2. Select to initiate the test.
3. Raise the engine to 2500 RPM.
Scroll up and down to command the valve that switches vacuum to the EGR valve on and off. Use the EGR TEMP and ST TRIM parameters on the screen to determine if exhaust gas is indeed being recirculated.
When EGR SYS reads Off, expect low EGR TEMP. When EGR SYS reads On, the EGR TEMP should rise and the ST TRIM values should change.
4. When you have completed testing the EGR system, exit.

**To conduct a fuel pump test:**

1. Select **Actuator Tests > Fuel Pump** from the Main Menu.
A test initiation screen displays.
2. Select to initiate the test.
“In Progress” flashes and an operational pump vibrates and makes noise for 30 seconds, after which time the test automatically shuts off.

16.3 Testing Transmission Systems

Toyota, Lexus and Scion transmission systems provide code information.

16.3.1 Code Reading Connectors

Transmission diagnostic connectors and adapters are shown in Figure 16-8 on page 202.

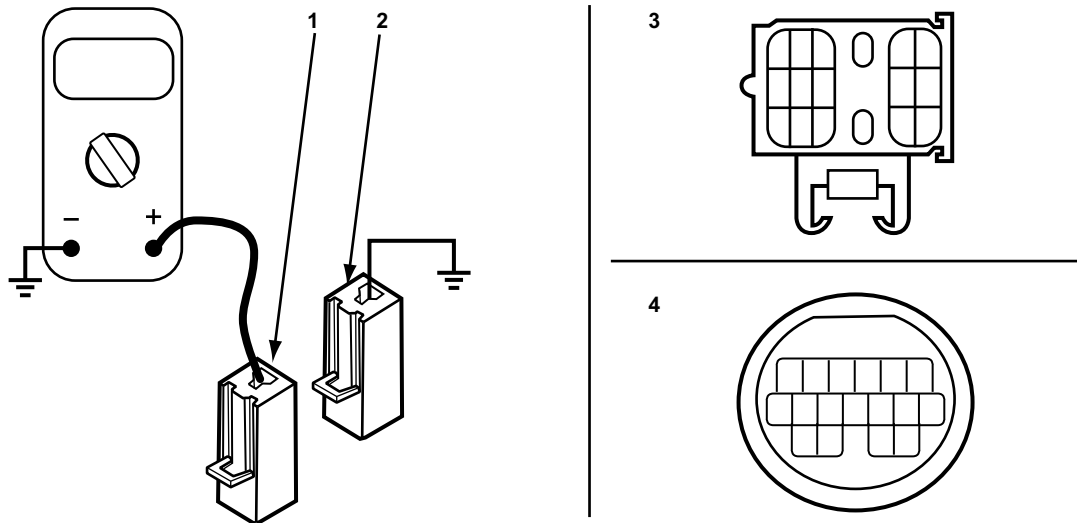

- 1— Positive meter lead to pin DG
- 2— Jump to ground (ignition and OD switches on)
- 3— Use TOY-1 adapter
- 4— Use TOY-2 adapter

Figure 16-8 Transmission connectors

16.4 Testing ABS Systems

Toyota, Lexus and Scion ABS provides code information.

16.4.1 Code Reading Connectors

ABS diagnostic connectors are shown in Figure 16-9.

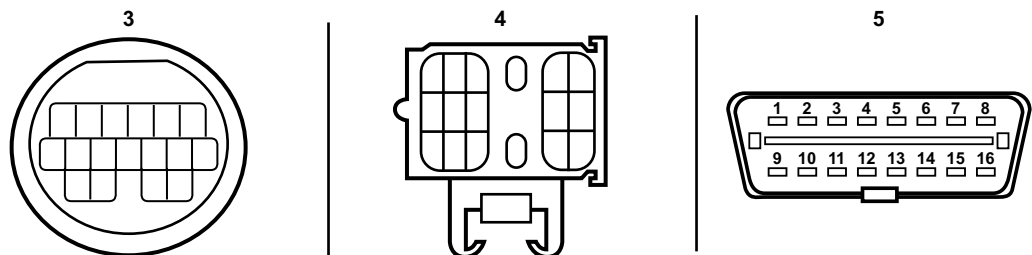

- 1— Use TOY-2 adapter
- 2— Use TOY-1 adapter
- 3— Use OBD-II adapter

Figure 16-9 Antilock brake system connectors

Some early systems require disconnecting a service wire or installing a jumper wire in order to initiate a flash code display (Figure 16-8).

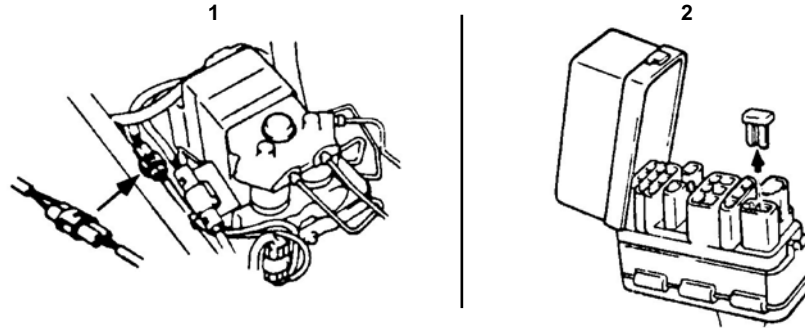

- 1— Disconnect service wire (some models)
 2— Disconnect Wa to Wb jumper (some models)

Figure 16-10 Antilock brake system connectors



NOTE:

When reading codes or data using TOY-1 or TOY-2 connectors, use the battery pack or an external power source.

16.5 Testing Supplemental Restraint Systems (SRS)

Toyota, Lexus and Scion SRS provides code information.

16.5.1 Reading SRS Codes

For all models except 2000 and later Celica, Echo, and MR2, use Auto Code Read while connected to the diagnostic link connector.



To read codes for all vehicles except 2000 and later Celica, Echo, and MR2:

1. Turn the key on with the engine off and wait 20 seconds.
2. Select **Code Functions > Auto Code Read**.



NOTE:

Pay attention to the terminal connecting position to avoid a malfunction.



To read codes for 2000 and later Celica, Echo, and MR2, and most 2001 and later models:

1. Turn the ignition switch on and wait for approximately 20 seconds.
2. Connect DLC3 terminal Tc to terminal CG (Figure 16-11).

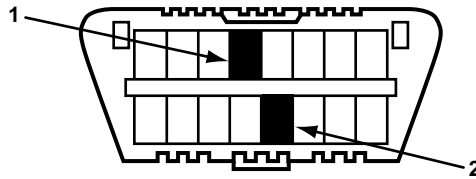

Figure 16-11 DLC3

1— Terminal # 4 - CG

2— Terminal #13 - TC



To read codes for 2000 and later Celica, Echo, and MR2:

1. Connect a jump wire between terminals Tc and CG of the DLC3 (Figure 16-11).
2. Turn the ignition switch on and wait for approximately 20 seconds.

No Codes Set Confirmation

The following signs indicate that the airbag system functions properly:

- The SRS lamp is unlit prior to connecting the scan tool.
- After selecting Auto Code Read, the SRS lamp flashes continuously and the display reads: "No Codes Present".
- After exiting Auto Code Read, the SRS lamp turns off.

Low Source Voltage

The following signs indicate low source voltage in the airbag system:

- The SRS lamp flashes or is continuously lit before connecting.
- After entering Auto Code Read, the SRS lamp flashes continuously and the display reads: "No Codes Present".
- After exiting Auto Code Read, the SRS lamp resumes flashing or turns on continuously.



NOTE:

A discharged battery or a faulty airbag sensor assembly may cause low source voltage.

16.5.2 Code Clearing



To clear SRS codes from 2000 and later Echo, Celica, and MR2, and most 2001 and later models:

1. Connect two jumper wires to terminals #13 and #6 of DCL3 (16-pin OBD-II) (Figure 16-12).
2. Turn the ignition switch on and wait approximately six seconds.
3. Starting with the Tc terminal, alternately ground terminal Tc then terminal A/B twice each in cycles of 1.0 second (Figure 16-13). Ensure that terminal Tc remains grounded.

Several seconds after the clearing procedure is complete (Step 3), the SRS warning lamp blinks in a 50 ms/second cycle to indicate codes have been cleared (Figure 16-13)

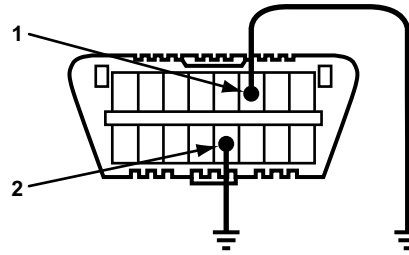

- 1— Terminal # 6 - A/B
- 2— Terminal #13 - Tc

Figure 16-12 Ground DLC3 terminals

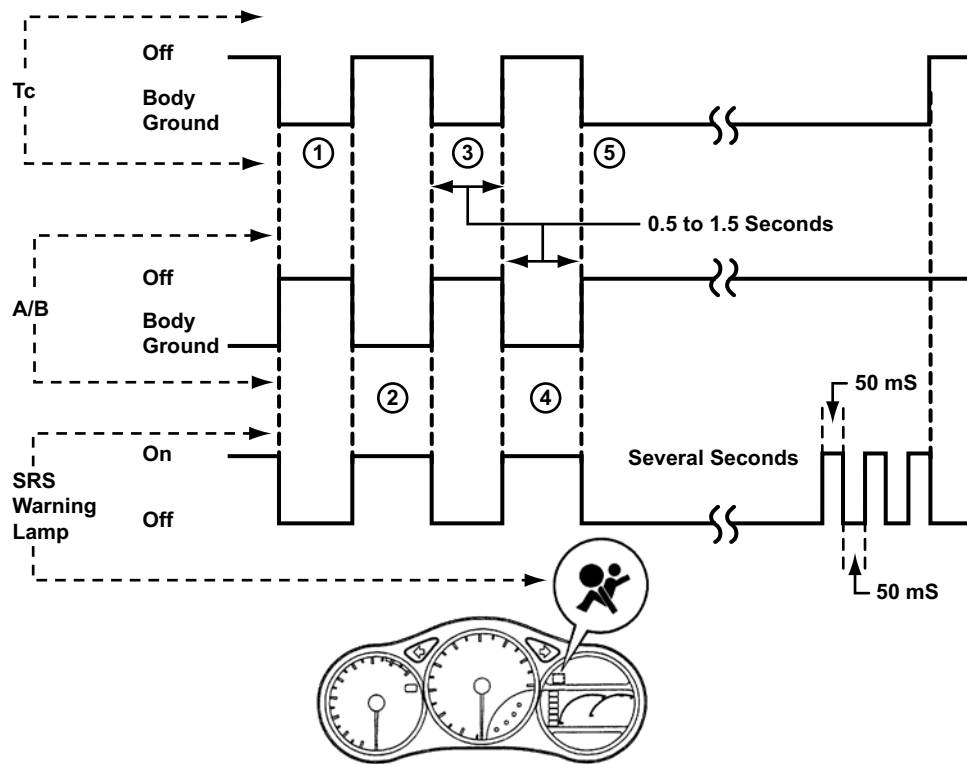

Figure 16-13 SRS (airbag) code clearing



To clear SRS codes on most other vehicles:

1. Switch the ignition on without starting the engine.
2. Connect a jumper wire between terminals #4 and #13 of the DLC3 (16 pin OBD-11) (Figure 16-11).
Codes should now display.
3. Some vehicles may require this method:
 - a. Within 10 seconds after codes begin to display, remove the jumper.
 - b. Wait up to 3 seconds for the ABS warning lamp to light up.

- c. Reconnect the jumper between terminals #4 and #13 of the DLC3 within 2 to 4 seconds after ABS warning lamp lights.
 - d. Disconnect the jumper after the ABS warning lamp is on for 2 to 4 seconds.
4. Switch the Ignition off while jumper wire is still in place.

This chapter explains how to test 1994–later OBD-II vehicles. Most vehicles are equipped with two testing modes: Generic OBD-II and Enhanced OBD-II. The EPA requires all 1996–later vehicles sold in the USA to meet OBD-II standards.

Some 1994–95 vehicles may appear to be OBD-II equipped, they may not be fully compliant. Check the VECI label to determine if a 1994–95 vehicle is an OBD-I or OBD-II model.

The following information and procedures are specific testing in Generic OBD-II mode. For general scan tool testing information, see the user's manual for your diagnostic tool.

17.1 OBD-II and What it Means

The term OBD stands for On Board Diagnostics. OBD-II is a system that the Society of Automotive Engineers (SAE) developed in order to standardize automotive electronic diagnosis so technicians could use the same scan tool to test any make and model without special adapters.

The SAE established guidelines that provide the following:

- A universal diagnostic test connector, known as the data link connector (DLC), with dedicated pin assignments.
- A standardized location for the DLC, visible under the dash on the driver's side.
- A standardized list of diagnostic trouble codes (DTCs).
- The ability of the vehicle system to record a snapshot of operating conditions when an emissions-related fault occurs.
- Expanded diagnostic capabilities that record a code whenever a condition occurs that affects vehicle emissions.
- The ability to clear stored codes from vehicle memory with the scan tool.
- A glossary of standard terms, acronyms, and definitions used for system components.

In addition, SAE has published hundreds of pages defining a standard communications protocol that establishes the hardware, software, and circuit parameters of OBD-II systems. Unfortunately, the vehicle manufacturers have different interpretations of this protocol. As a result, the generic OBD-II communications scheme used varies, depending on the vehicle.

SAE publishes recommendations, not laws, but the Environmental Protection Agency (EPA) and the California Air Resources Board (CARB) made many SAE recommendations legal requirements, which were phased in over a three-year period. Beginning in 1994, vehicles with a new engine management computer were supposed to comply with OBD-II standards. For 1995, OBD-II systems were to appear on about 40% of the new vehicles sold. The government granted waivers for some 1994–95 OBD-II systems to give manufacturers time to fine-tune their systems. Beginning with the 1996 model year, all new vehicles sold in the USA must be fully OBD-II compliant.

17.2 Selecting The Generic Test Mode

The OBDII Generic selection is available from the Manufacturer Selection menu.

17.3 Connecting To The Vehicle

The 16-pin OBD-II adapter is used to connect the scan tool to the DLC (Figure 17-1). The adapter attaches to the end of the data cable with captive screws.



NOTE:

A Personality Key must be inserted into the adapter for testing in the generic mode.

The DLC is a 16-pin connector. The female half is on the vehicle, and the male end is on the scan tool cable. The connector is D-shaped and keyed so the two halves mate only one way. Pins are arranged in two rows of eight, numbered 1 to 8 and 9 to 16 (Figure 17-1)

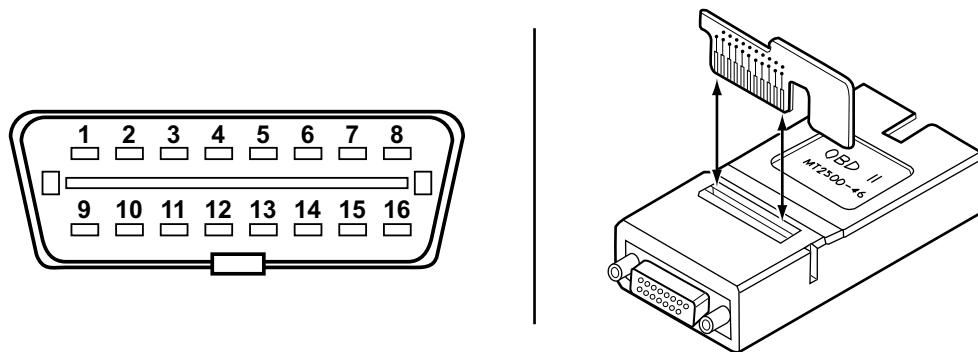

Figure 17-1 16-pin OBD-II data link connector (DLC), test adapter, and personality key

Table 17-1 16-pin OBD-II connector pinout

PIN	FUNCTION	PIN	FUNCTION
1	Manufacturer's discretion	9	Manufacturer's discretion
2	Bus+ Line, SAE J1850	10	Bus- Line, SAE J1850
3	Manufacturer's discretion	11	Manufacturer's discretion
4	Chassis ground	12	Manufacturer's discretion
5	Signal ground	13	Manufacturer's discretion
6	2002–earlier: Manufacturer's discretion 2003–later: ISO 15765-4 CAN	14	2002–earlier: Manufacturer's discretion 2003–later: ISO 15765-4 CAN
7	K-line, ISO 9141	15	L-line, ISO 9141
8	Manufacturer's discretion	16	Vehicle battery positive

The DLC cannot be hidden behind panels and must be accessible without the use of tools. (Figure 17-2). Although out of the normal line of sight, the DLC should be clearly visible to a crouching technician.

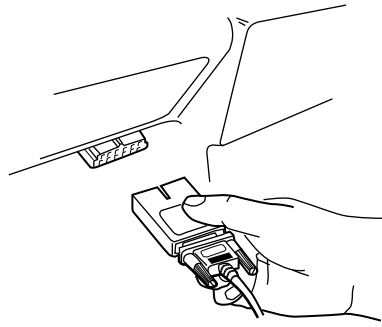

Figure 17-2 OBD-II diagnostic connector location

If the DLC is not visible, you may find a manufacturer's sticker on the lower steering column cover, or below the left side of the dash center, indicating the DLC location.

The DLC is designed for scan tool access only. You cannot jumper any of the terminals to display codes on the instrument cluster warning lamp, or malfunction indicator lamp (MIL).



To connect to a vehicle:

- Follow the on-screen connection instructions, and then select to continue. The Main Menu displays.

17.4 Main Menu Selections

There are up to three main menu choices in Generic Testing Mode:

- **Codes and Data Menu**—displays a sub-menu of choices for viewing parameter data, diagnostic trouble codes (DTCs), and various oxygen sensor (O2S) signal characteristics.
- **Custom Setup**—configures scan tool settings, see the manual for your diagnostic tool.
- **Review Movie**—appears on a menu only after a movie is recorded. The Review Movie feature works the same in Generic Testing Mode as with specific manufacturers. See the manual for your diagnostic tool for details.

17.4.1 Codes and Data Menu

This selection is available from the Main Menu in Generic OBD-II mode.

Select Codes and Data Menu and a sub-menu of the following choices displays

- **Codes Only**—displays diagnostic trouble codes (DTCs).
- **O2 Monitors**—displays various signal characteristics of O2S response.
- **Pending Codes**—displays codes whose setting conditions occurred once, but must occur two or more times before a DTC is set.
- **Data (No Codes)**—displays various sensor, switch, and actuator inputs and outputs.
- **Freeze Frame**—displays certain data readings that the vehicle stores when a DTC is set.

Scan Tool Communication

The selections from the Codes and Data Menu require that the scan tool communicate with the powertrain control module (PCM). The ignition must be on to establish communication. After making a selection, the scan tool displays a “waiting for PCM to communicate” message.

If communication with the PCM is not established within 5 seconds, the scan tool displays a “no communication” message. This message stays on the screen until communication is established, or the operation is canceled. When communication is established, the scan tool will go to the selected function.

Interrupted Communication

If communication is interrupted during testing, but power remains connected, a “No Communication” message displays.

This could happen if the connection to the vehicle is loose or the ignition is turned off. This message stays on the screen until communication is reestablished, or the operation is canceled.

Codes Only

This selection displays DTCs in a standard, 5-character alphanumeric format.

The first character, a letter, defines the system where a code was set, or displays “U” if there is a communication fault (Table 17-2).

Table 17-2 First DTC character indications

1 st DTC Character	System Where a Code Set
P	Powertrain
B	Body
C	Chassis
U	Network

The second character will be a 0, 1, 2, or 3 (Table 17-3). The meaning of a 2 or 3 varies according to the system character (P, B, C, or U).

Table 17-3 Second DTC character indications

2 nd DTC Character	Type of Code
0	SAE-defined (generic) code
1	Manufacturer-defined (enhanced) code
2 & 3	P2 = SAE-defined (generic) code
	P3000-P3399 = Manufacturer specifications
	P3400-P3899 = Reserved by SAE for future use
	B2 & C2 = Reserved for manufacturers
	B3 & C3 = Reserved by SAE for future use

The third DTC character indicates the system where the fault occurred (Table 17-4):

Table 17-4 *Third DTC character indications*

3 rd DTC Character	System Where Fault Occurred
1	Fuel or air metering problem
2	
3	Ignition malfunction or engine misfire
4	Auxiliary emission control system problem
5	Vehicle or idle speed control system problem
6	Computer or output circuit fault
7	Transmission control problem
8	

The final characters in the DTC tell you the conditions that triggered the code. Different sensors, actuators and circuits are assigned blocks of numbers; and the lowest number in the block indicates a general malfunction. This is the generic DTC. Higher numbers in the assigned block—called enhanced codes—provide more specific information, such as low or high voltage, slow response, or an out-of-range signal.

Code Clearing

The scan tool can clear trouble codes and other saved data from PCM memory.



To clear the codes:

1. Select **(\$04) Clear Emissions Related Data** from the Select Service menu.
A confirmation screen displays.
2. Selecting erases all codes, freeze frame data, and test results from PCM memory.
Follow the on-screen prompts to clear the data and return to the menu.

If the code-clearing operation fails for any reason, the previous codes reappear. If this occurs, repeat the Clear Codes operation.

O2 Monitors

This selection lets you view various O2S signal response characteristics.

There are two different monitors: one for pre-converter sensors and one for post-converter sensors. The PCM looks for three main things from the pre-converter oxygen sensor:

- Maximum voltage
- Minimum voltage
- Switching rate

The PCM looks for the sensor signal to rise above 600 millivolts, fall below 300 millivolts, and switch in less than 100 milliseconds to monitor the pre-converter O2S. The PCM performs a fuel control routine and examines the pre-converter sensor readings during known air/fuel mixtures. The PCM looks for specific sensor values, based on the mixture levels it provides.

The post-converter check is significantly different. The PCM sees almost no switching when the converter is functioning properly. To test the sensor, the PCM forces a fuel control routine that the converter cannot compensate for, and then monitors the sensor response.

Both sensors are also monitored continuously for open and short circuits.



To perform an O2S Monitors test:

1. Select **(\$05, 06, 07) Display Test Param./Results** from the Select Service menu.
2. Select **(\$05) Oxygen Sensor Monitoring** from the submenu.
A test options menu displays.
3. Select a test from the list.

What the sensor response signal tests measure are shown in Figure 17-3.

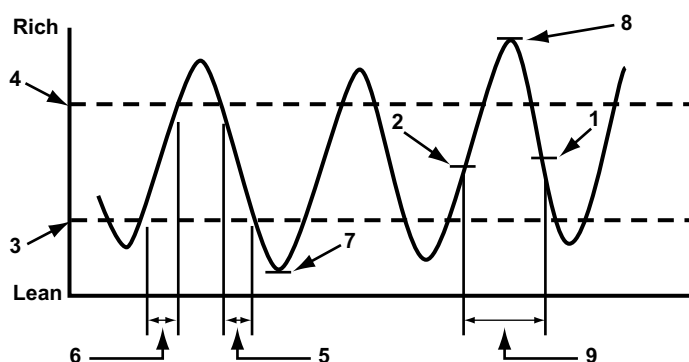

- 1— Test 1: Rich to lean sensor threshold voltage
- 2— Test 2: Lean to rich sensor threshold voltage
- 3— Test 3: Low sensor voltage for switch time calculation
- 4— Test 4: High sensor voltage for switch time calculation
- 5— Test 5: Rich to lean sensor switch time
- 6— Test 6: Lean to rich sensor switch time
- 7— Test 7: Minimum sensor voltage for test cycle
- 8— Test 8: Maximum sensor voltage for test cycle
- 9— Test 9: Time between sensor transitions

Figure 17-3 O2 sensor monitor tests

Pending Codes

Pending codes set when operating conditions are out of the normal range, but not all the criteria to set a DTC occur. For example, a failure must occur on two consecutive trips or drive cycles before certain OBD-II codes set. In this case, a pending code is recorded during the first trip when the failure first occurs.

Data (No Codes)

OBD-II vehicles transmit PCM operating data to the scan tool, but do not broadcast DTCs in this mode. The scan tool does not affect PCM operation, and the vehicle can be driven normally for road testing. Use the Codes Only selection to read DTCs.

Freeze Frame

This selection lets you view certain data parameter readings that the vehicle stores the instant that a code (DTC) is set. Parameters displayed will vary, depending on the code.

The following chapter provides definitions and operating ranges for the data stream parameters that display on the scan tool. The scan tool can display all of the operating parameters available from the electronic control module of the vehicle, which provides two basic kinds of parameters:

- Digital (discrete) parameters are those that can be in only one of two states, such as on or off, open or closed, high or low, rich or lean, and yes or no. Switches, relays, and solenoids are examples of devices that provide discrete parameters on the data list.
- Analog parameters are displayed as a measured value in the appropriate units. Voltage, pressure, temperature, time, and speed parameters are examples of analog values. The scan tool displays them as numbers that vary through a range of values in units, such as pounds per square inch (psi), kilopascal (kPa), degrees Celsius (°C), degrees Fahrenheit (°F), kilometers per hour (KPH), or miles per hour (MPH).

Some data parameters display in numbers that range from 0 to 100, 0 to 255, or 0 to 1800. These ranges are used because in each case, it is the maximum number range that the control module transmits for a given parameter. However, many parameter readings never reach the highest possible number. For example, you never see a vehicle speed parameter reading of 255 MPH.

The maximum range of a parameter often varies by year, model, and engine. On these applications, the word “variable” appears in the range heading, but typical sampled values observed under actual test conditions are in the parameter description when available.

Parameters may also be identified as input signals or output commands.

- Input or feedback parameters are signals from various sensors and switches to the electronic control module (ECM). They may display as analog or discrete values, depending on the input device type.
- Output parameters are commands that the ECM transmits to various actuators, such as solenoids and fuel injectors. They are displayed as discrete parameters, analog values, or as a pulse-width modulated (PWM) signal.

Parameters are presented as they appear on the screen. Most parameter descriptions are in alphabetical order, but there are exceptions. Often, the same parameter goes by a different name when used on more than one make, model, engine, or control system. In these instances, all of the applicable parameter names are listed in alphabetical order before the description.

The scan tool may display names for some data parameters that differ from names displayed by a factory tool and other scan tools.

The data parameter descriptions in this manual were created from a combination of sources. For most parameters, some basic information was provided by the respective manufacturers, then expanded through research and field-testing. Parameter definitions and ranges may expand as more test results become available. For some parameters, no information is currently available.

Always use a digital multimeter, power graphing meter, or lab scope, to further validate the displayed values. If data is corrupted on multiple data parameters, do not assume that the control module may be faulty. This corrupt data may be caused by improper communication between the scan tool and the control module. See the troubleshooting sections of the user’s manual for the diagnostic tool you are using for more details on communication problems.

Interpreting Pressure Parameters

Parameters that indicate ambient air pressure (barometric pressure) and high or low pressure inside the intake manifold are major input parameters used by the ECM to control the air-fuel ratio and spark advance in relation to engine load.

The engine control system must measure the atmospheric air pressure and the pressure in the intake manifold to determine engine load and calculate the required fuel metering and spark advance. Three pressure measurements or calculations are necessary:

- Barometric pressure (BARO) is the ambient atmospheric air pressure. The barometric pressure changes with altitude and temperature. At sea level, barometric pressure is 14.7 psi, 101.3 kPa, or 29.9 "Hg.
- Manifold vacuum is pressure in the intake manifold that is below atmospheric pressure on a running engine. The manifold vacuum is measured in relation to atmospheric pressure. High vacuum is low pressure.
- Manifold absolute pressure (MAP) is a combination of atmospheric pressure and vacuum, or the relative difference between the air pressure outside the manifold and the vacuum inside. MAP is measured in relation to zero pressure (high vacuum).

BARO, manifold vacuum, and MAP have the following relationships (Figure 18-1).

- $MAP = BARO - \text{vacuum}$
- $\text{Vacuum} = BARO - MAP$
- $BARO = MAP + \text{vacuum}$

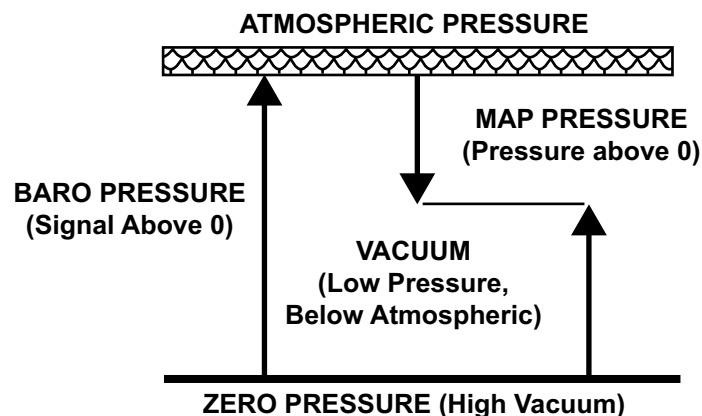

Figure 18-1 Air pressure relationships

Turbocharger boost operation also affects manifold pressure. When a turbocharger is providing boost pressure, manifold absolute pressure rises above atmospheric pressure.

Depending on the control system and sensors used on an engine, one or more of the MAP, BARO, or vacuum parameters display on the scan tool. It may also display boost pressure on a turbocharged engine.

Parameters display as both a voltage reading from the sensor and as a pressure measurement in either kilopascal (kPa) or inches of mercury ("Hg). The preset measurements for all three values are in kPa.

Alphabetic List of Parameters

Numerics

# Codes	302
#CARB CODES	336
#CODES	336
#CODES	467
+B VOLTS	467
+BM VOLTS	336
+BM	336
1 INDICATOR	490
1 POS SWITCH	490
1 SYS BRAKE	280
1-2 ERROR(SEC)	490
1-2 SHIFT (SEC)	490
1-2 SOL CKT STATUS	491
1-2 SOLENOID	490
1ST GEAR	336
1ST GEAR	491
1TOUCH_DN	302
2 FRAMES	280
2 INDICATOR	491
2 POS SWITCH	491
2-3 ERROR(SEC)	490
2-3 SHIFT (SEC)	490
2-3 SOL CKT STATUS	491
2-3 SOLENOID	490
2-3T_CCS	491
2-4 BRK PRS SW	491
2-4 BRK SOL(%)	491
24B(%)	491
2nd AIR MON CMPL	336
2nd AIR MON ENA	336
2ND GEAR	336
2ND GEAR	491
2nd PRESSURE SWITCH	491
2nd PRESSURE SWT	491
2ND SELECTED	336
2ND SELECTED	491
2nd Tire	484
2WD HIGH LAMP	486
3-2 DWNSHIFT SOL	492
3-2 SOL CKT STATUS	491
3-2 TIME	492
3-2 TIMING SOL	492
3-4 ERROR(SEC)	490
3-4 SHIFT (SEC)	490
3RD GEAR	336
3RD GEAR	492
3rd PRESSURE SWITCH	492
3rd PRESSURE SWT	492
40 CYCLES	336

4-3 DOWNSHIFT.....	492
4TH GEAR.....	336
4TH GEAR.....	492
4th PRESSURE SWITCH.....	492
4th PRESSURE SWT.....	492
4WD ACTIVE.....	280
4WD ENGAGED.....	336
4WD HIGH LAMP.....	486
4WD LOW ACTV.....	486
4WD LOW LAMP.....	486
4WD LOW SW.....	336
4WDPCWMOU.....	492
4WDPCWMST.....	492
4WDHIGLMP_4X4M.....	486
4WDINP_SW_4X4M.....	486
4WDLOWLMP_4X4M.....	486
4WDMODE_L.....	492
5TH GEAR.....	493
5V REF (V).....	337

A

A/C CLUTCH RELAY.....	337
A/C CLUTCH.....	337
A/C COMP SW.....	337
A/C CONSMPT PWR (KW).....	467
A/C CUT SIG.....	337
A/C CUT.....	337
A/C ENABLED.....	337
A/C ENABLED.....	493
A/C HI-SIDE (psi).....	337
A/C IDLE UP VSV.....	337
A/C LOAD(V).....	338
A/C MAG CLUTCH.....	338
A/C PRESS (kPa).....	337
A/C PRESS (psi).....	337
A/C PRESS(V).....	338
A/C REFRIG.....	475
A/C RELAY.....	337
A/C RELAY.....	338
A/C RELAY.....	338
A/C REQUEST SW.....	338
A/C REQUEST.....	338
A/C SIG.....	337
A/C SW.....	338
A/C SWITCH.....	338
A/C SWITCH.....	338
A/C TEMP S (°).....	339
A/C TEMP S (V).....	339
A/F ADJ-B1.....	339
A/F ADJ-B2.....	339
A/F ALPHA-B1 (%).....	339
A/F ALPHA-B2 (%).....	339
A/F LEARNED.....	339

A/F LEFT (V)	339
A/F RATIO	340
A/F RATIO	340
A/F RATIO(:1).....	340
A/F RIGHT (V).....	339
A/F SSR TEST B1	340
A/F SSR TEST B1	340
A/F SSR TEST B2	340
A/F SSR TEST B2	340
A/T 1 SWITCH.....	493
A/T 1 SWT	493
A/T 2 SWITCH.....	493
A/T 2 SWT	493
A/T 2-1 SWITCH.....	493
A/T 2-1 SWT	493
A/T C.P.C. SOL VLV A ACTUAL.....	493
A/T C.P.C. SOL VLV A COMMAND.....	493
A/T C.P.C. SOL VLV B ACTUAL.....	493
A/T C.P.C. SOL VLV B COMMAND.....	493
A/T C.P.C. SOL VLV C ACTUAL	493
A/T C.P.C. SOL VLV C COMMAND.....	493
A/T D SWITCH	340
A/T D SWITCH	493
A/T D SWT	340
A/T D SWT	493
A/T D3 SWITCH	340
A/T D3 SWITCH	494
A/T D3 SWT	494
A/T D4 SWITCH	340
A/T D4 SWITCH	494
A/T D4 SWT	494
A/T D5 SWITCH	494
A/T D5 SWT	494
A/T N SWITCH	494
A/T N SWT	494
A/T NP SWITCH.....	494
A/T P SWITCH	494
A/T P SWT.....	494
A/T R SWITCH	340
A/T R SWITCH	494
A/T R SWT	494
A/T SHIFT SOL VLV A	494
A/T SHIFT SOL VLV B	494
A/T SHIFT SOL VLV C	494
A/T SHIFT SOL VLV D	494
A/T SHIFT SOL VLV E	494
A/T T.C.C. SOL VLV A.....	495
A/T T.C.C. SOL VLV	495
AAT	340
AAT(°).....	458
ABS BATT (V).....	280
ABS IGN (V)	280
ABS LAMP.....	280

ABS LAMP.....	478
ABS SRI STATUS.....	280
ABS STOP.....	280
ABS WARN LAMP.....	281
ABS_ACTIV.....	495
ABS_VOLT.....	280
ABS_WARN.....	478
ABSLAMP.....	281
ABSOL PRES (V).....	341
ABSOTPB(%).....	341
ABV VAC(%).....	341
ABV VENT(%).....	341
AC (CMPL).....	341
AC (ENA).....	341
AC HI PRESS OPN.....	342
AC MON CMPL.....	342
AC MON ENA.....	342
AC_REQ_SIG.....	342
Acc On Sw.....	302
ACC PRESS SENS.....	281
ACC PRESS SENS1 (V).....	281
ACC Relay Mon.....	303
ACC RELAY.....	342
ACC SEN.....	281
ACC Sw.....	302
ACCEL DEG (%).....	467
ACCEL ENRICH.....	342
ACCEL IDL POS.....	342
ACCEL LRN VAL #1.....	342
ACCEL LRN VAL #2.....	342
ACCEL LRN VAL#1.....	342
ACCEL LRN VAL#2.....	342
ACCEL POS FROM EFI.....	378
ACCEL POS SIG.....	281
ACCEL POS1 (%).....	344
ACCEL POS1(%).....	342
ACCEL POS1(%).....	467
ACCEL POS1(V).....	343
ACCEL POS2 (%).....	344
ACCEL POS2(%).....	342
ACCEL POS2(%).....	467
ACCEL POS2(V).....	343
ACCEL SSR #1 AD(V).....	343
ACCEL SSR #1 AD(V).....	344
ACCEL SWITCH.....	495
ACCELERATOR (%).....	281
ACPPA(%).....	343
ACPPB(%).....	343
ACCS.....	343
ACCS=A/C.....	343
ACCS=A/C.....	495
ACG Control.....	344
ACIS VSV.....	344

ACM BATTERY VOLTAGE	343
ACM(%)	345
ACMRLY	343
ACP	343
ACSW	303
ACSW	343
ACT VLV TMNG(°)	343
ACT VLV TMNG(°)	495
ACT VSV (ON/OFF)	344
ACTUAL CKP	344
ACTUAL CMP	344
AF B1 HEATER	345
AF B1 LAMBDA	345
AF B1 S1 HEATER	345
AF B2 HEATER	345
AF B2 LAMBDA	345
AF B2 S1 HEATER	345
AF FB (ST FUEL TRIM) B1	345
AF FB (ST FUEL TRIM) B2	345
AF FB (ST FUEL TRIM)	345
AF FB AVG (LT FUEL TRIM) B1	345
AF FB AVG (LT FUEL TRIM) B2	345
AF FB AVG (LT FUEL TRIM)	345
AF FB AVG	345
AF FB CMD B1	346
AF FB CMD B2	346
AF FB CMD	346
AF FB COND	346
AF FB	345
AF LAMBDA B1	345
AF LAMBDA B2	345
AF LAMBDA	345
AF SENSOR (mA)	346
AF SENSOR B1	346
AF SENSOR B2	346
AF SENSOR	346
AFS Off Sw	303
AFSA	495
AFSB	495
AI STATUS	346
AICV VSV	346
AIR BAG LAMP	478
Air Cond Sw	303
AIR CONTRL SOL	346
AIR CONTRL SOL	346
AIR DIVERT SOL	346
Air Inlet Damper Pulse	299
Air Inlet Mode	299
AIR INTAKE SOL	346
Air Mix Pulse-D	299
Air Mix Pulse-P	299
Air Out Pulse-D	299
Air Out Pulse-P	299

AIR PMP PRS (kPa).....	347
AIR PUMP RELAY.....	347
AIR PUMP SIGNAL.....	347
AIR PUMP.....	347
AIR PUMP.....	347
AIR STAT.....	458
AIR SWITCH SOL.....	347
AIR TEMP (°).....	348
AIR.....	458
AIR.....	475
AIRFLOW (g/s).....	348
AIRFLOW (Hz).....	348
AIRFLOW (kg/h).....	348
AIRFLOW (m3/h).....	348
AIRFLOW (mS).....	348
AIRFLOW (mV).....	348
AIRFLOW (V).....	348
AIRFLOW RESET.....	348
AIRFLOW(g/s).....	458
AIT PMP PLS PRS(kPa).....	347
AKNOCK.....	348
AKNOCK-1.....	348
AKNOCK-2.....	348
Alarm Function.....	303
All Unlock/Opn-Cls.....	303
ALL_LAMPS.....	349
ALL_SEG.....	349
ALT CTRL.....	344
Alt L-Term Sig.....	303
ALTERNATOR.....	349
ALTF(%).....	349
ALTT(V).....	349
Ambi Temp Sensor.....	299
Ambi Temp.....	299
Ambient Temp Shift.....	299
AMBIENT TEMP.....	349
AMBIENT TEMP.....	349
AMBIENT TEMP.....	467
AP SENSOR (A).....	495
AP SENSOR (B).....	495
AP SENSOR (V).....	495
AP SENSOR A VOLT.....	495
AP SENSOR B VOLT.....	495
AP SENSOR DEG (°).....	495
AP SENSOR1 V.....	495
AP SENSOR2 V.....	495
APP (%).....	344
APP 1 (V).....	349
APP 1&2 AGREE.....	349
APP 2 (V).....	349
APP 3 (V).....	349
APP AVE.....	350
APP CTP SW.....	350

APP D(%)	458
APP E(%)	458
APP F(%).....	458
APP SENSOR (°)	350
APP SENSOR (V)	350
APP SENSOR 1 (%).....	344
APP SENSOR 1 (°)	350
APP SENSOR 1 (V)	349
APP SENSOR 2 (%).....	344
APP SENSOR 2 (°)	350
APP SENSOR 2 (V)	349
APP SENSOR B (V).....	350
APP SENSOR-A (V).....	350
APP SENSOR-B (V).....	350
APP(%).....	350
APP1 (%).....	344
APP1 (V).....	350
APP1/APP2 AGREE.....	349
APP1/APP3 AGREE.....	349
APP2 (%).....	344
APP2 (V).....	350
APP2(%).....	350
APP2/APP3 AGREE.....	349
APP3 (%).....	344
APP3 (V).....	350
APS	349
Armed State Indicator.....	303
ARPMDES.....	351
ARPMDES.....	351
ASCD CRUISE	496
ASCD OD CUT.....	351
ASCD SIGNAL	281
ASD RELAY	351
AST.....	351
ASYNCH PULSE	351
AT Lockup A or B.....	351
AT OD CANCEL	496
AT_HORN.....	303
ATC SLIP (RPM)	486
ATCHK.....	351
ATF INDICATOR.....	496
ATF SENSOR.....	496
ATF TEMP 1	352
ATF TEMP INDICATOR.....	496
ATF TEMP SENSOR (°).....	496
ATF TEMP SENSOR (V)	496
ATM PRESS	352
ATM PRESS	352
ATM PRESS(V)	352
ATSDLB.....	352
AUTO 4WD LAMP	486
Auto Blow Up.....	299
AUTO LIGHT SW	303

Auto Light Sw	303
Auto Lock Delay	304
Auto Lock/Shift	304
AUTO LRN TIMER	352
AUTO OIL	352
Auto Unlock/Shift	304
Auto Wiper	304
AUTOLMP	303
AUX. BATT V	467

B

B/FUEL SCHDL (msec)	352
B_AJAR	304
B1S1 HTR AMPS	353
B1S1 L-R (Sec)	353
B1S1 L-R(Sec)	357
B1S1 R-L (Sec)	353
B1S1 R-L(Sec)	357
B1S2 HTR AMPS	353
B2S1 HTR AMPS	353
B2S1 L-R (Sec)	353
B2S1 L-R(Sec)	357
B2S1 R-L (Sec)	353
B2S1 R-L(Sec)	357
B2S2 HTR AMPS	353
BACK DIM DUTY CYCLE (%).....	304
Back Door Open Sw	304
Back Door Open Sw	304
BACK DOOR SW	304
Backup Light Sw	304
BACK-UP LIGHT SW	353
Back-Up Light Transistor	304
BACKUPLMP	304
BARO (V).....	353
BARO S (V)	353
BARO S	353
BARO SENSOR (V)	353
BARO Sensor	353
BARO TCM.....	353
BARO	353
BARO	496
BARO(Hz).....	354
BARO(inHg).....	458
BARO(kPa).....	458
BARO(V).....	496
BARO_EGR_SOL	354
BAROPRES.....	353
BASADJ.....	354
BATT (V).....	305
BATT (V).....	354
BATT INSIDE AIR.....	467
BATT TEMP (°).....	354
BATT TEMP (V).....	354

Batt Volt 1	484
Batt Volt 2	484
Batt Volt 3	484
Batt Volt 4	484
Batt Volt 5	484
BATT(V).....	496
BATT_SAVR	305
BATTERY (V).....	354
BATTERY BLOCK MAX(V).....	467
BATTERY BLOCK MINIMUM(V)	467
BATTERY BLOCK(V) V01 to V14.....	467
BATTERY LAMP.....	478
BATTERY SOC.....	468
BATTERY TEMPERATURE 1 to 3	468
BATTERY VOLTS.....	478
BBP SENSOR	354
BLM CELL	355
BLM	355
BLOCK F INFO.....	356
BLOCK LEARN	355
BLOWER FAN SW	356
Blower Level.....	299
BLOWR FAN SW.....	496
BOO.....	281
BOO.....	356
BOO.....	486
BOO.....	497
BOO=BRAKE SW	356
BOOST PRS VSV	356
BOOST SENSOR.....	356
BOOST VSV.....	356
BPA.....	356
BRACKET(Ohms).....	296
BRAKE BOOSTER PRESS SENSOR	356
BRAKE LAMP CMD	281
BRAKE LAMP.....	281
BRAKE LAMP.....	478
BRAKE SW.....	281
BRAKE SW.....	356
BRAKE SW.....	497
BRAKE SW1.....	357
BRAKE SW2.....	357
BRAKE SWITCH B.....	356
BRAKE SWITCH	356
BRAKE SWT	356
BRAKE WARN LAMP	282
BRAKE_WARN.....	478
BrakeOnOff.....	356
BrakeOnOff.....	497
BRK_FLUID.....	305
Buttom Prs Buzz.....	299
BUZZER	282
BYPASS AIR 1	357

BYPASS AIR 357

C

C SHAFT SPD (km.h) (MPH)	357
C.C. CANCEL HISTORY	357
C_LOCK_SW	305
C_UNLOCK_SW	305
CACBYP	358
CAL ID	358
CAL/LD VAL(%)	358
CAL/LD VALUE	358
CALC B1 TWC(°)	358
CALC B2 TWC(°)	358
CALC CAT TMP	358
CALC CLSD THRT	359
CALC LOAD (%)	358
CALC LOAD(%)	358
CALC TPS(%)	497
CALC VACUUM	358
CAM HI TO LO	359
CAM LO TO HI	359
CAM PHASE ACT (°)	359
CAM PHASE DES (°)	359
CAM PHASE DUTY (%)	359
CAM PHASE VARI	359
CAM SENSOR	359
CAN CIRC 1	360
CAN CIRC 2	360
CAN CIRC 3	360
CAN CIRC 4	360
CAN CIRC 5	360
CAN CIRC 6	360
CAN CIRC 7	360
CAN CIRC 8	360
CAN CIRC 9	360
CAN CTRL VSV	360
Car Finder	309
CASeGND (V)	360
CASeGND(V)	497
CAT (CMPL)	341
CAT (ENA)	341
CAT CMPL	360
CAT ENA	360
CAT MON TEMP	360
CAT MONITOR CONDITION B1	360
CAT MONITOR CONDITION B2	360
CAT MONITOR CONDITION	360
CAT MONITOR	341
CAT MONITOR	360
CAT OT FC CYL#1	361
CAT OT FC CYL#2	361
CAT OT FC CYL#3	361
CAT OT FC CYL#4	361

CAT OT FC CYL#5.....	361
CAT OT FC CYL#6.....	361
CAT OT FC CYL#7.....	361
CAT OT FC CYL#8.....	361
CAT TEMP B1S1.....	361
CAT TEMP B1S2.....	361
CAT TEMP B2S2.....	361
CAT TEMP B2S21.....	361
CAT TMP B1S1.....	361
CAT TMP B1S2.....	361
CAT TMP B2S1.....	361
CAT TMP B2S2.....	361
CAT.....	475
CAT_mon_ready.....	361
CATEMP11.....	361
CATEMP11(°).....	458
CATEMP12(°).....	458
CATEMP21.....	361
CATEMP21(°).....	458
CATEMP22(°).....	458
CC ENGAGED.....	361
CC INHIBITED.....	361
CC ON/OFF SW.....	362
CC RES/ACC SW.....	362
CC RES/ACC.....	362
CC SET/CST SW.....	362
CCM CMPL.....	362
CCM ENA.....	362
CCNT.....	478
CCNT_TPMS.....	309
CCNTABS.....	282
CCP COMMAND.....	362
CCS_FAULT.....	497
CCSFault.....	362
CCSFault.....	497
CDCV.....	362
CHASSIS PITCH.....	362
CHECK GAUGES LAMP.....	478
CHECK MODE.....	362
CHECK MODE.....	468
CHIME.....	362
CHRGLP.....	363
CHT SENSOR.....	363
CHT.....	363
CHT_FAULT.....	363
CHTIL.....	363
CHTIL_FAULT.....	363
CHTS(V).....	370
CKP A NO PULSE.....	363
CKP A NOISE.....	363
CKP B NO PULSE.....	363
CKP B NOISE.....	363
CKP NO PULSE.....	363

CKP NOISE	363
CKP RESYNCS.....	363
CKP SENSOR(RPM).....	363
CLCH_SOL(%)	497
CLEAR FLOOD	363
CLR DIST (km) or (mi).....	459
CLR DIST	363
CLUTCH SWITCH.....	364
CLV	364
CMP 1 NO PULSE	364
CMP 2 NO PULSE	364
CMP A NO PULSE	364
CMP A NOISE	364
CMP B NO PULSE	364
CMP B NOISE	364
CMP CTRL (°)	364
CMP CTRL CMD (°)	364
CMP NO PULSE (COUNTS).....	364
CMP NOISE 1	364
CMP NOISE 2	364
CMP RESYNCS	364
CMP SENSOR(RPM)	364
CMP_FAULT	364
CoastCISol (mA).....	365
CoastCISol.....	364
CoastCISol(mA).....	497
CoastClutchSol.....	497
COLD STARTUP	365
COLP.....	365
Com ACC G/Way.....	305
Com B-Door P/W.....	305
Com Body No. 4	305
Com Body No. 5	305
Com Combi Sw.....	306
Com CRLAC.....	306
Com CRLS	306
Com CRRAC	306
Com CRRS.....	306
Com Cruise Ctrl.....	306
Com CTR Console	305
Com D-Door Mtr	306
Com D-Door	306
Com D-Door/Mirr	306
Com Double Lock	307
Com D-Seat Sw.....	307
Com D-Seat.....	307
Com Entry & Start.....	307
Com FL Seat A/C	307
Com FR Seat A/C.....	307
Com Master Sw	307
Com Mayday G/Way.....	307
Com Mayday	307
Com Meter.....	308

Com Park Assist	308
Com P-Door Mtr	306
Com P-Door.....	306
Com P-Seat	308
Com Pwr B-Door	308
Com R-Console	308
Com RL-Door Mtr	306
Com RL-Door	306
Com RR-Door Mtr.....	306
Com RR-Door.....	306
Com S/W Pad Sw.....	308
Com Slide Roof	308
Com TDS.....	308
Com Tilt & Tele	308
Com Tire Pressure.....	309
COMMEGR(%).....	365
COMMEVAP(%).....	365
COMMTAC(%).....	365
Communication CTR Console	305
Communication FL Seat A/C	307
Communication FR Seat A/C	307
Communication RL Seat A/C.....	306
Communication RR Seat A/C	306
COMP MON	341
COMP MON	341
COMPONENT MONITOR	360
COMPONENT MONITOR	365
COMPONENTS.....	475
Compressor Mode	299
Comprs/Def Oper	300
COND FAN LO	365
COND FAN	365
CONVERTER TEMP	468
COOL FAN(%).....	365
COOLANT (°)	366
COOLANT (V)	366
Coolant Temp	300
COOLANT TEMP	366
COOLANT TEMP	366
COOLANT TEMP	468
COOLANT(°)	459
COOLING FAN SPD.....	468
COOLING FAN	366
COPENPLAT_4X4M.....	486
COUNTERSHAFT SPEED (km.h)(MPH)	497
COUNTERSHAFT SPEED (RPM)	497
COURTESY LAMP SW	309
Courtesy Sw	309
CPP	366
CPP_SW	366
CPP_SW	497
CRANK #2 RPM.....	366
CRANK REQUEST.....	367

CRANK SENSOR.....	359
CRANK.....	366
CRANKING RPM.....	367
CRANKING.....	367
CRSHSN1	296
CRUISE BRAKE SW	367
CRUISE CANCEL SW.....	367
CRUISE CONTROL	367
CRUISE CONTROL	478
CRUISE INDICATOR.....	367
CRUISE LAMP	367
CRUISE LIGHT	367
CRUISE MAIN SW	367
CRUISE MASTER (MAIN) SWT.....	367
CRUISE RESUME SWT.....	368
CRUISE SET SWT	368
CRUISE SW	367
CRUS REQ TH (°)(%)	368
CTP (APS).....	368
CTP SW.....	368
CTP	368
CUR SLIP ADAPTS.....	487
Curr Com Rain.....	309
CURRENT DTC.....	468
CURRENT GEAR.....	498
CURRENT SENSOR (V).....	368
CYL #1 (%).....	369
CYL #1 (%).....	369
CYL #2 (%).....	369
CYL #2 (%).....	369
CYL #3 (%).....	369
CYL #3 (%).....	369
CYL #4 (%).....	369
CYL #4 (%).....	369
CYL #5 (%).....	369
CYL #5 (%).....	369
CYL #6 (%).....	369
CYL #6 (%).....	369
CYL #7 (%).....	369
CYL #7 (%).....	369
CYL #8 (%).....	369
CYL #8 (%).....	369
CYL 1 (2, 3, 4, 5, or 6) MISFIRE	368
CYL 1 DEACT SOL COMMAND	369
CYL 4 DEACT SOL COMMAND	369
CYL 6 DEACT SOL COMMAND	369
CYL 7 DEACT SOL COMMAND	369
CYL ALL MISS RATE	369
CYL DEACT SYSTEM COMMAND.....	368
CYL x MISFIRES.....	369
CYL.....	368
Cyl. DEACT. PERFORMANCE TST	368
CylHdTemp (V)	370

D

D BUCKLE SW	477
D Door Cty Sw	309
D Door Key Sw-UNLOCK	311
D Door Warning Sw	312
D INDICATOR	498
D Mirror Memory M1	309
D Mirror Memory M2	309
D POS SWITCH	498
D Seat Buckle Sw	310
D SWITCH	370
D SWITCH	498
D/C Converter Control ELD Unit	370
D/C CTRL VOL (V)	370
D/M MUFFLER SW	370
D_ABAGR(Ohms)	296
D_Airbag(Ohms)	296
D_AirBAG2(Ohms)	296
D_PReTNR(Ohms)	296
D_UP_SW	310
D3 INDICATOR	498
D3 SWITCH	498
D4 INDICATOR	498
D4/D5/D INDICATOR	498
D5 INDICATOR	498
D5 SWITCH	498
DAB	296
DAMPING CTRL	370
DBW (drive by wire)	370
DCCSV DC (%)	498
DCCSV SLIP (RPM)	498
DCRKMf	370
DCT_CNT	370
DD_LOCK	310
DD_UNLOCK	310
DECEL ENLEAN	370
DECEL FUEL C/OFF	370
DECELE SEN	282
DECELERAT SEN (m/s2)	282
DECELERAT SEN 2 (m/s2)	282
DECHOKE	371
DELTA SOC	468
DEPLOYMENTS	296
DES IDLE RPM	371
DESIRED FAN RPM	371
DESIRED IDLE	371
DESIRED TP (%)	371
DFT ERROR CODE (\$XX)	499
DFT MONITOR (\$XX)	499
DFT RESULT (\$XX)	499
DIC FUEL INFO SWITCH	479
DIC PERSONALIZATION SW	479
DIC SELECT SWITCH	479

DIC TRIP INFO SWITCH	479
Dimmer HI Sw	310
Dimmer Sw	310
DIMMING INPUT (V)	310
DIMMING LEVEL (%)	310
DISCHARGE RQST SOC (W)	468
DISPLAY COOLANT TEMP	479
Display Ext OFF Sens	310
Display Ext ON Sens	310
DISPLAYED FUEL LEVEL (%)	479
DISPLAYED ODOMETER	479
DISPLAYED OIL PRESSURE	479
DIST DTC CLEAR	371
DIST DTC CLEAR	468
DISTANCE SINCE DTC CLEARED	371
DLIDLKSW	310
DLIDULSW	310
DOMELM_SW	311
Door Key Linked Lock Sw	311
Door Key Linked Unlock Sw	311
Door Lock (Lock)	311
Door Lock (Unlock)	311
Door Lock Sw Status	311
Door Lock Sw	311
Door Lock Sw-LOCK	311
Door Lock Sw-UNLOCK	311
DOOR SW AS	312
DOOR SW DR	312
Door Sw LF	312
Door Sw LR	312
Door Sw RF	312
Door Sw RR	312
DOOR SW-RR	312
Door Unlock Sw Status	312
Door Unlock Sw	312
Down/Door Key	312
DOWNLVR	371
DOWNSHIFT REQ 1	500
DOWNSHIFT REQ 2	500
DOWNSHIFT REQUEST 1	500
DOWNSHIFT REQUEST 2	500
DOWNSHIFT SWITCH	500
DOWNSHIFT SWT	500
DPFE (V)	371
DPFEGR	372
DR_BUKL	479
DR_PTENS(Ohms)	296
DRAJLMP_IC	479
DRIV_DR	479
DRIVE CONDITION ID	469
DRIVE CONDITION	469
DRIVE CounT	372
DRIVE CounT	500

DRIVE DIST (km)(mile)	372
DRIVE POSITION	500
DRIVE TIME (min).....	372
DRIVECNT	372
DRIVECNT	500
Driver Lock Position Sw.....	311
Driver PSD Sw.....	312
DRIVER/LR DOOR AJAR SW.....	312
DRIVING MILEAGE.....	469
DRL Function.....	313
DRL_L	313
DRL_R.....	313
DRLK_RLY	312
DRUNLK_RLY	313
DRV IMPACT ID	296
Drv P/W Auto Sw	313
Drv P/W Down Sw	313
Drv P/W Up Sw.....	313
DRV STATUS	372
DRV_SW	500
DRVR BELT	296
Drvr Door Lock Posit Sw	313
DS_AB(Ohms).....	297
DSBELTR(Ohms)	297
DTC CouNT	372
DTC STORED	372
DTC	469
DTC	500
DTC_CNT	282
DTC_CNT	297
DTC_CNT	372
DTC_CNT	500
DWN_SW	500
DWN_SW	500

E

E/G Condition	314
E-ABV STEP POS.....	372
E-ABV STEPS	372
EACV	373
EC IGN RLY FBK	373
EC IGN RLY	373
ECB MTR RELAY 2	282
ECB MTR RELAY	282
ECB RELAY 2.....	282
ECB RELAY.....	282
ECL (%)	500
ECONO LIGHT	373
ECRK1.....	373
ECRK2.....	373
ECT (°).....	366
ECT (V).....	373
ECT 1 (°).....	373

ECT 1 (V).....	373
ECT FROM EFI	378
ECT LAMP 1.....	373
ECT LAMP 2.....	374
ECT Power Mode Sw	314
ECT SENSOR (°)	373
ECT SENSOR (V)	373
ECT Snow Mode Sw	314
ECT	373
ECT(°).....	459
ECT(V).....	500
ECT_FAULT	374
ECT_TCM.....	500
ECU CTRL MODE.....	469
ECU TYPE.....	469
ECYL1	374
ECYL2	374
EFE COMMAND.....	374
EGR (CMPL)	341
EGR (ENA)	341
EGR BOOST SOL.....	374
EGR CMPL.....	374
EGR COMMAND	374
EGR ENA	375
EGR ERR(%).....	459
EGR L COM	375
EGR LIFT SENSOR	375
EGR LIFT	375
EGR MON	375
EGR PCT(%).....	459
EGR POS(%).....	375
EGR POS(V)	375
EGR SOLENOID	374
EGR STEP POS.....	375
EGR STEPS	375
EGR SYS.....	374
EGR SYSTEM.....	374
EGR TEMP (°).....	375
EGR TEMP (V)	375
EGR V L COMMAND	375
EGR VAC SOL(%).....	376
EGR VENT SOL(%)	376
EGR VLS	375
EGR SYS.....	475
EGR_FAULT	376
EGRBARO.....	376
EGRBARO.....	376
EGRC SOLENOID.....	376
EGRCFault	376
EGRFOpen.....	376
EGRFShort.....	376
EGRMDSD	376
EGRVFault	376

EGRVR (%)	376
EGRVR_FAULT	377
EGT SENSOR (°C) (°F).....	377
EGT SENSOR (V)	377
ELD.....	370
ELEC LOAD SIG	377
ELEC LOAD SW.....	377
ELEC LOAD	377
ElecPrsCtrl.....	377
ElecPrsCtrl.....	500
Emiss Gas Sens	300
ENABLE RELAY	282
ENCODER GEAR	487
ENCODER RETURN VOLTAGE	487
ENCODER SUPPLY VOLTAGE	487
ENG LOAD (%)	377
ENG OIL PRESS SW	377
ENG OIL TEMP	377
ENG OIL TMP	283
ENG ON RUN TIME	377
ENG RESTART COND.....	377
ENG RUN TIME	377
ENG RUN TIME	469
ENG SPD FROM EFI	378
ENG SPD	378
ENG STOP RQST	469
ENG TORQ (N-M)	378
ENG WARM UP RQST.....	469
ENGINE LOAD (%)	378
ENGINE MOUNT.....	378
ENGINE OIL LIFE	378
ENGINE OIL PRESSURE	378
ENGINE RPM.....	378
ENGINE RPM.....	459
ENGINE RPM.....	480
Engine Running.....	314
ENGINE SPD (RPM)	469
ENGINE SPEED (RPM)	501
ENGINE SPEED2 (RPM)	501
Engine Status	314
ENGTRQ SIGNAL (%)	378
Entry Delay	314
EOP SENSOR (kgf/cm2).....	379
EOP SENSOR (V)	379
EOT SENSOR (°C) (°F).....	379
EOT SENSOR (V)	379
EPC (V)	379
EPC	500
EPC(V)	501
EPS SIGNAL	379
EPS	379
EQ RAT	379
EQ RAT	459

EQ RAT11	379
EQ RAT11	460
EQ RAT12	460
EQ RAT13	460
EQ RAT14	460
EQ RAT21	460
EQ RAT22	460
EQ RAT23	460
EQ RAT24	460
EQ RAT31	460
EQ RAT32	460
EQ RAT41	460
EQ RAT42	460
ESC ACTIVE	379
ESC COUNTER	379
ESC FAILURE	379
EST ECT (°C) (°F)	380
ESTIMAT SPD RAT	501
ETC_ACT (°)	380
ETC_DES (%)	380
ETR (%)	501
EVAP (A/FS) (CMPL)	341
EVAP (A/FS) (ENA)	341
EVAP BYPASS SOL	380
EVAP CMPL	380
Evap Ctrl	300
EVAP CVS VALVE	380
EVAP CVS VLV	380
EVAP ENA	380
EVAP mon ready	380
EVAP MON	380
EVAP MONITOR	341
EVAP MONITOR	360
EVAP MONITOR	380
EVAP MONITOR	380
EVAP PC DUTY (%)	380
EVAP PC SOL	381
EVAP PCT(%)	460
EVAP PF SW	381
EVAP PRES (V)	381
EVAP PURG(V)	381
EVAP PURGE (%)	381
EVAP SOLENOID	381
EVAP SYS	475
Evap Temp	300
EVAP TST	381
EVAP VENT SOL	381
EVAP_VP(H2O)	460
EVAP_VP(Pa)	460
EVAPCP	381
EVAPCP%	381
EVAPCPFault	382
EVAPCV%	382

EVAPCV(%).....	382
EVAPCV_FAULT	382
EVAPCVFault	382
EVAPPrgFlw (V)	382
EVAPSOAK	382
EVAPVM%.....	382
EVAPVM_FAULT	382
EVAPVMA	382
EVMV(A).....	382
EX VTC DTY B1	283
EX VTC DTY B2	283
EXH BYPASS VSV	382
EXH CTRL VSV.....	383
EXH GAS CTL VSV.....	383
EXH V/T LEARN.....	283
EXH V/T LEARN.....	383
EXH/V TIM-B1	283
EXH/V TIM-B2	283
EXHAUST OXYGEN	383
EXTXRSH.....	297

F

F AXLE REQ	487
F AXLE SW LCKD.....	487
F BNK UP	383
F DNSTM O2S (V).....	422
F Fog Light Sw	314
F INJECTOR (mS).....	383
F PROSHAFT (RPM)	487
F UPSTM O2S (V).....	422
FAIL #1	383
FAIL #1	384
FAIL #1	384
FAIL #2	383
FAIL #2	384
FAIL #2	384
FAN 1.....	384
FAN 2.....	384
FAN 3.....	384
FAN CTRL ECT (°C) (°F) (V).....	384
FAN CTRL	366
FAN HIGH CTRL	384
FAN LOW CTRL.....	384
FAN MOTOR	384
FAN SPEED (RPM)	384
FAN_DUTY(%)	384
FAS.....	501
FAST IDLE SOL	384
FAT TERMINAL	501
FAT	385
FAULT CODE DISPLAY	385
FC AIRFLOW	370
FC CTP.....	385

FC IDL	385
FC TAU	385
FCIL	385
FCIL_FAULT	385
FIA CTRL SOL	385
FL ABS STATUS	283
FL PRS SEN (V)	283
FL SENS RANGE	477
FL SENS VOLTS	477
FL SENS WEIGHT(lbs)	477
FL VSC STATUS	283
FL W/C SEN	283
FL W/C SENS (V)	283
FL WHEEL ACCEL (m/s2)	284
FL WHEEL SPD	284
FLASH TO PASS SW	315
FlexFuel (Hz)	385
FLG_OTLK	501
FLI (%)	385
FLI	385
FLI(%)	460
FLI_FAULT	385
FLUID LEV SW	284
FLUID TEM (V)	386
FLUID TEMP (°)	496
FLUID TEMP (V)	496
FLUID TEMP(V)	501
FLUID_TEMP	501
FOG_F_SW	314
FOGRLY_F	315
Foot Air Leak	300
Foot Lights	315
Foot/Def Auto Mode	300
FORWARD & REAR G (m/s2)	284
FORWARD SWITCH	501
FP (%)	386
FP MODE	386
FP RES RELAY	386
FP RLY	386
FP SENSOR (kPa) (mmHg) (in.Hg) (V)	386
FP	386
FP_RLY	386
FPCM	284
FPFault	386
FPM	386
FPMonitor	386
FPTDR (V)	386
FR ABS STATUS	284
FR ACM SOL CURRENT	386
FR ACM SOL MAX CURRENT	387
FR ACM SOL MIN CURRENT	387
FR FOG SW	315
FR OPERATE TORQ	284

FR PRS SEN (V)	284
FR RQST TORQ	284
FR SENS RANGE	477
FR SENS VOLTS	477
FR SENS WEIGHT(lbs).....	477
FR VSC STATUS.....	284
FR W/C SEN	284
FR W/C SENS (V)	284
FR WASHER SW	315
FR WHEEL ACCEL (m/s2).....	285
FR WHEEL SPD.....	285
FR WIPER HI	315
FR WIPER INT	315
FR WIPER LOW.....	315
FR WIPER STOP	315
FRONT FOG LAMP SW.....	314
Front Fog Light Sw	314
Front Fog Sw	314
FRONT O2 (mV).....	422
Front Washer Switch	314
Front Wiper High	314
Front Wiper Int Volume.....	315
Front Wiper Int.....	314
Front Wiper Low	315
Front Wiper Stop.....	315
FRONT WIPERS ACTIVE	315
FRP PSI.....	387
FRP	460
FRP(V).....	387
FRP_DSD	387
FRP_FAULT	387
FRT.....	387
FRT(V).....	387
FRWPPRKSW.....	316
FRZSTR (1)	387
FSS B1	387
FSS B2	387
FSS.....	387
FT CELL	387
FT LEARN	387
FT SENSOR (°C) (°F) (V).....	388
FTP SENSOR.....	388
FTP SNSR.....	388
FTP(V).....	388
FTP_FAULT	388
FTT SENSOR (°C) (°F) (V).....	388
FUEL (%) FRONT	389
FUEL (%) REAR.....	389
FUEL CMPL	388
FUEL CUT DECEL	388
FUEL CUT	388
FUEL CUTOFF SOL.....	388
FUEL ENA	389

Fuel Gauge.....	480
FUEL LEVEL (AVERAGE).....	389
FUEL LEVEL (L).....	389
FUEL LEVEL (mV)	389
FUEL LEVEL (V)(%).....	385
FUEL LEVEL(V)	389
Fuel Lid Open Sw	316
FUEL LVL SENSOR (V)(%).....	385
FUEL METER CTRL (%).....	389
FUEL MISFIRE.....	389
FUEL PMP SP CTL	389
FUEL PRES SOL	389
FUEL PRESS	460
FUEL PRESS(V)	389
FUEL PRS UP VSV.....	389
FUEL PUMP CTRL.....	390
FUEL PUMP RELAY	390
FUEL PUMP	390
FUEL REF VOL (V)	390
FUEL SENDER (V).....	385
FUEL STATUS.....	390
FUEL SYS #1	390
FUEL SYS #2	390
FUEL SYS (CMPL).....	341
FUEL SYS (ENA)	341
FUEL SYS MON.....	391
FUEL SYS MONITOR	360
FUEL SYS	390
FUEL SYS	475
FUEL SYS1	390
FUEL SYS1	460
FUEL SYS2	390
FUEL SYS2	460
FUEL TANK CAP(L)	391
FUEL TEMP (°).....	391
FUEL VOLATI.....	391
FUEL(PSI)	391
FUEL_GAUGE	391
FUEL_LEVEL(%).....	391
FUEL_LEVEL(%).....	480
FUEL_mon_ready	391
FuelLvlInp(%).....	391
FuelLvlInp(V)	391
FuelPumpA.....	391
FUELPW.....	392
FUELPW(mS).....	392
FUELPW1 (mS).....	392
FUELPW2 (mS).....	392
FUELSYS1	390
FUELSYS2	390
FuelTankPrs(V).....	392

G

GATE or CARGO DOOR AJAR.....	480
GEAR POSITION	392
GEAR RAT	502
GEAR RATIO.....	502
GEAR	392
GEAR	498
GEAR	501
GEAR_MAX.....	501
GEAR_RA	502
GEN L TERMINAL.....	392
GEN LIGHT	392
GEN LIGHT	502
GEN OUT(V)	392
GEN OUT(V)	502
GEN(%)	392
GEN(%)	502
GEN. FIELD.....	392
GEN_FAULT	393
GEN_MON	393
GENERATOR (%).....	393
GENFDC%	393
GENVSD(V).....	393
GR_RATIO	502
G-SENSOR (V).....	285

H

HAC PRS ZONE.....	393
Hand Free Tel	300
Hazard Answer Back	316
Hazard Sw	316
HAZARD.....	316
HBEAMSW	316
HC PRES SW	502
HC(%).....	502
HC_SOL(%).....	502
HD_LMP_SW	480
Head Lamp Sw 1	316
HEAD LAMP SW 2	316
Head Lamp SW 2	316
HEAD LAMP SW	316
Head Light Sw	316
Headlamp Auto Signal	303
Headlamp Signal	316
HEADLAMP WASHER	316
HEADLAMP	316
HEADLIGHT SW	393
HEADLIGHT SW	502
HEATED CAT	475
HEATER CAT (CMPL).....	341
HEATER CAT (ENA).....	341
HFC	393

HFC_FAULT	393
HI A/C PRESS.....	393
HI BEAM SW	317
HI CLUTCH(%).....	502
HI PS PRESS	393
HI PS PRESSURE	393
HI PS PRESSURE	502
HIGH ALTITUDE	394
HIGH BATTERY	394
HIGH BEAM LAMP.....	480
HIGH BEAM SELECT	317
High Beam SW	317
High Flasher Sw	315
HIGH GEAR	502
High Mount STOP Light transistor.....	317
HIGH RAD FAN	366
Hist Com Rain	317
HISTORY DTC	470
H-Level Warning Sig.....	316
HO2 SNSR-1 (mV)	394
HO2 SNSR-2 (mV)	394
HO2S (AF) B1 S1 HEATER	394
HO2S (AF) B2 S1 HEATER	394
HO2S (mA)	394
HO2S 1 HEATER	394
HO2S 2 HEATER	394
HO2S 3 HEATER	394
HO2S B1 H CUR	395
HO2S B1 HEATER CURRENT (mA).....	395
HO2S B1 S1 (V)	395
HO2S B1 S2 (V)	395
HO2S B1 S2 H CUR.....	395
HO2S B1 S2 HEATER CURRENT (mA)	395
HO2S B1 S2 HEATER	394
HO2S B2 H CUR	395
HO2S B2 HEATER CURRENT (mA).....	395
HO2S B2 S1 (V)	395
HO2S B2 S2 (V)	395
HO2S B2 S2 C (A).....	395
HO2S B2 S2 H CUR.....	395
HO2S B2 S2 HEATER CURRENT (mA)	395
HO2S B2 S2 HEATER	394
HO2S HEATED OXYGEN SENSOR (A/F).....	395
HO2S S1 (mA).....	394
HO2S S1 (V).....	395
HO2S S-1 HEATER	394
HO2S S2 (V).....	395
HO2S S2 H C (A)	395
HO2S S2 HEATER CURRENT (mA).....	395
HO2S S2 HEATER	395
HO2S S2 HTR	395
HO2S S3 (V).....	395
HO2S_mon_ready.....	395

HO2S11 (mA)	395
HO2S12 (mA)	395
HO2S21 (mA)	395
HO2S22 (mA)	395
HOLD LIGHT	502
HOLD SWITCH	503
Hood Courtesy Sw.....	309
HOOD OPEN SW.....	317
HOOD SW	317
Hood Sw	317
Horn Sw	317
HORN_TPM	317
HOT MODE	503
HOT OPEN LOOP	395
HTD CAT MON CMPL.....	396
HTD CAT MON ENA	396
HTM_CNT	503
HTM_DIS.....	503
HTR11	396
HTR11_Fault	396
HTR11Fault	396
HTR12	396
HTR12_Fault	396
HTR12Fault	396
HTR21	396
HTR21_Fault	396
HTR21Fault	396
HTR22	396
HTR22_Fault	396
HTR22Fault	396
HTRCM11(A)	396
HTRCM12(A).....	396
HTRCM21(A).....	396
HTRCM22(A).....	396
HV BATT CH RQST	470
HV COMM	285

I

I/L On/ACC Off	319
I/Light On/Unlock	319
I/P PULLY RPM.....	396
I/P PULLY SPD (rpm)	396
IAB CTRL SOL	397
IAB HI CTRL SOL.....	397
IAB LOW CTRL SOL	397
IAC (%).....	397
IAC COM (%).....	399
IAC COM	397
IAC COMMAND (COUNTS)	397
IAC DIRECTION.....	397
IAC STEPS.....	397
IAC(%)	397
IAC/AAC (%).....	397

IAC/AAC STEPS	397
IAC=IDLE AIR(%)	503
IAC_FAULT	398
IACFault	398
IACV(%)	398
IACV(mS)	398
IAR SOL	398
IASV	398
IAT (°)	348
IAT (V)	398
IAT 1	348
IAT 1	398
IAT 2	348
IAT 2	398
IAT FROM EFI	378
IAT SENSOR 1 (°)	348
IAT SENSOR 1	398
IAT SENSOR 2 (°)	348
IAT SENSOR 2	398
IAT	398
IAT(°)	461
IAT=ACT	503
IAT=ACT(V)	503
IAT_FAULT	398
IATDC	398
IATDC(V)	398
IATLC(V)	398
IB BATTERY	470
IDL A/V LEARN	399
IDLE AIR CONTRL	397
IDLE CTRL SOL (%)	399
IDLE LEARN	399
IDLE STOP CTRL	399
IDLE SW	285
IDLE SW	359
IDLE SWITCH	359
IDLE TARGET TH (°)	399
IDLE UP SOL	399
IDLE UP VSV	399
IDLING REQUEST	470
IDLING	399
IG LEVEL	399
IG MISFIRE	399
IG Sw Signal	319
IG T ADJ (V)	399
IG VOLTAGE	285
IG1 LEVEL	399
IG1 Relay Mon1	318
IG1 Relay Mon2	318
IG2 Relay Mon1	318
IG2 Relay Mon2	318
IGDSBL	400
IGKEY_ILLU	318

IGN (V)	400
IGN ACC SIG	400
IGN ADJ TERM	400
IGN ADV(°)	400
IGN ADVANCE (°)	400
IGN ADVANCE(°)	400
IGN ADVANCE(°)	503
IGN CYCLE DTC	400
IGN CYCLE DTC	487
IGN CYCLES	400
IGN EVENTS X	401
IGN FUEL VTD	401
IGN ON SW	318
Ign On Sw	318
IGN TIMING(°)	400
IGN TIMING(°)	461
IGN. CYCLES SINCE LAST DTC	480
IGN_(V)	297
IGN_KEY	480
IGN_V	503
IGNITION (V)	400
IGNITION 0	318
IGNITION 1 (V)	401
IGNITION 1 (V)	480
IGNITION 1	318
IGNITION 3	319
IGNITION ACCESSORY	319
IGNITION SW	401
IGNITION	401
IGNITION	401
IGRTNE (V)	401
IGRTNI (V)	401
I-Key Hatch	317
I-Key Lock	317
I-Key Panic	318
I-Key Pwr Window Down	318
I-Key Trunk	317
I-Key Unlock	318
ILLUMINAT(%)	401
Illumination Sw	319
Illumination System	319
ILM CONTROL	503
IMA (V)	401
IMA OUTPUT (kw)	401
IMA REQUEST (kW)	402
IMA STANDBY	402
IMA TORQUE	402
IMMOBILIZER	402
IMRC MON SW	402
IMRC POS SENSOR	402
IMRC SOL VLV	402
IMRC SOL	402
IMRC VLV CMD	402

IMRC VP SENSOR (V).....	402
IMRC	402
IMT (IMRC) VALVE SW	402
IMT (IMRC) VLV CMD	402
IMT (IMRC) VLV SWT	402
IMT VLV SW	402
IMTV (%)	403
IMTV	402
IMTV(%)	403
IMTV_FAULT	403
INADVERTENT POWER RELAY	319
INDDRNG (ON/OFF).....	403
INDICATOR DIMMING	320
INDICATORS.....	504
INDLRNG (ON/OFF)	403
INDNRNG (ON/OFF).....	403
INDPRNG (ON/OFF).....	403
INDRNG (ON/OFF).....	403
INGEAR.....	403
INGEAR.....	504
INH SW1 (ON/OFF).....	403
INH SW2 (ON/OFF).....	403
INH SW3 (ON/OFF).....	403
INH SW3M (ON/OFF).....	403
INH SW4 (ON/OFF).....	403
INI COOL TEMP	404
INI COOL TMP	404
INI IAT TMP	404
Ini Threshold 1(gauge)	484
Ini Threshold 2(gauge)	484
Ini Threshold 3(gauge)	484
Ini Threshold 4(gauge)	484
Ini Threshold 5(gauge)	484
Initial Switch Info.....	484
Initial Switch.....	484
INJ #1 (mS)	404
INJ #1 PW (mS).....	404
INJ #2 (mS)	404
INJ #2 PW (mS).....	404
INJ #x (mS).....	404
INJ (mS)	404
INJ B1 (mS)	404
INJ B2 (mS)	404
INJ L(mS)	404
INJ L(mS)	404
INJ PULSE-B1(mS)	404
INJ PULSE-B2(mS)	404
INJ PW (mS).....	404
INJ PW B1(mS)	404
INJ PW B2(mS)	404
INJ(mS)	504
INJ1_Fault	405
INJ1Fault	405

INJ2_Fault	405
INJ2Fault	405
INJ3_Fault	405
INJ3Fault	405
INJ4_Fault	405
INJ4Fault	405
INJ5_Fault	405
INJ5Fault	405
INJ6_Fault	405
INJ6Fault	405
INJECTOR (mS)	404
INJECTOR MODE	405
INLET AIR TEMP	405
INPUT RPM	405
INPUT RPM	504
INST_VBAT	480
INT AIR CTL VSV	405
INT VOLUME	319
INT/V SOL B1 (%)	405
INT/V SOL B2 (%)	405
INT/V SOL-B1	405
INT/V SOL-B2	405
INT/V TIM B1 (°)	406
INT/V TIM B2 (°)	406
INTAKE AIR (°)	348
INTAKE AIR TEMPERATURE SENSOR(2)	348
INTAKE AIR TEMPERATURE SENSOR(2)	398
INTAKE AIR VSV	405
INTAKE AIR	406
INTAKE AIR	470
INTAKE AIR(°)	461
INTAKE CNTRL	406
INTAKE CTL VSV1	406
INTAKE CTL VSV2	406
INTAKE CTRL SOL	406
INTAKE VSV	406
INTEGRATR	406
INTERIOR LAMP DEFEAT	320
Interior Light ON Unlock	320
Interior Light	319
INTERNAL RESISTANCE(OHMS) R01-R14	470
ISC (%)	397
ISC STEP	397
ISOLT1	406
ISOLT2	406
ISOLT3	407
ISTPIM	407
IVS	407
IVS	407
IVSMDIR1	397
IVSMDIR2	397
IVSMSTP (DEC)	397
IXREF	407

IXREF/QXREF..... 407

K

K/D SERVO SW 504
 K/D SW 504
 KAMFUSE 407
 KEY CYL LK-SW 320
 Key Cyl Lock Sw 320
 Key Cyl Unlock Sw 320
 KEY CYL UN-SW 320
 KEY IN IGNITION..... 320
 Key Insert On Sw..... 320
 KEY ON SW 320
 Key Sw (Lock) 311
 Key Sw (Unlock) 311
 Key Sw-Lock..... 311
 Key Sw-Unlock 311
 Key Unlock Warn Sw 320
 Keyless Keep Lock 320
 Keyless Keep Unlock..... 320
 Keyless Lock 320
 Keyless Panic..... 321
 Keyless Pwr Rear Hatch..... 321
 Keyless Pwr Rear Trunk 321
 Keyless Pwr Sliding Left Door 321
 Keyless Pwr Sliding Right Door..... 321
 Keyless Unlock 321
 KICKDOWN SW 504
 KICK-DOWN SWITCH 504
 KNOCK ADVANCE (°)..... 407
 KNOCK CRRT VAL 407
 KNOCK CRRT(°)..... 407
 KNOCK CTRL EGR..... 407
 KNOCK CTRL 407
 KNOCK FB VAL..... 408
 KNOCK FB(°) 408
 KNOCK RET (°)..... 408
 KNOCK RETARD (°) 408
 KNOCK RETARD CYL 1 (°) 408
 KNOCK RETARD CYL 2 (°) 408
 KNOCK RETARD CYL 3 (°) 408
 KNOCK RETARD CYL 4 (°) 408
 KNOCK SENSOR..... 408
 KNOCK SNSR 1 (V) 408
 KNOCK SNSR 2 (V) 408
 KNOCK..... 407
 KNOCKR(°) 408
 KSOK..... 408

L

L SWITCH 408
 L SWITCH 504

LAMP.....	297
LAST SHFT (SEC)	504
LAST_ID	321
Latch Circuit.....	321
LATERAL G (m/s ²)	285
LBEAM_AUTO	321
LCHSTS	408
LDP_EVAPCP(A)	408
LDP_IDL(A)	408
LDP_MON(A)	409
LDP_REF(A).....	409
LDP_SLDV(A)	409
LDP_VSLD(V)	409
LEDA	504
LEDB	504
LEDC.....	505
LEFT FRONT SOLAR SNSR (V)	321
LEFT O2.....	383
LEFT TURN SIGNAL.....	480
Left Turn Sw	321
LEVER POS	505
LF MOTOR AMPS	286
LF MOTOR FBK	286
LF WHEEL (MPH)	286
LF_AJAR	322
LF_ID.....	322
LF_LRN	322
LF_MES.....	322
LF_NORM	322
LF_PSI.....	322
LF_PW (A).....	322
LF_REC.....	322
LF_WSPD.....	286
LFAWAKE	322
LFC.....	409
LFC_FAULT	409
LFDR_SW	322
LFIDPRG	322
LFLOBAT	322
LFPW_PEAK (A)	322
LFPW_SW.....	322
L-FRONT EMB	285
L-FRONT SOL.....	285
LFTRIM 1 (%).....	409
LFTRIM 2 (%).....	409
LG FL IDLE (mS).....	409
LHTURN_IND.....	323
LIFT SWITCH	409
Light Auto Sw	303
Light Control	319
Light Off Delay.....	323
Light Rheostat	480
LIGHT SENSOR (V)	321

Lighting Time	323
Lin Com	323
Lin Communication	323
LINE PRES (%)	505
LINE PRES(%)	409
LINE PRESS(A)	409
LINEDES (%)	505
LK BUTTON/SIG	323
LO SPEED CUT	410
LOAD (%)	410
LOAD ABS(%)	461
LOAD PCT(%)	461
LOAD PCT(%)	505
LOAD SIGNAL	377
LOAD(%)	461
LOAD(%)	505
Lock Posit Sw	313
LOCK SW AS	323
LOCK SW DR	323
Lock/IG On Drv	323
LOCKUP B DUTY (%)	505
LONG FT1(%)	462
LONG FT2(%)	462
LONG FT3(%)	462
LONG FT4(%)	462
LONGFT1(%)	410
LONGFT2(%)	410
LOOP STATUS (L)	410
LOOP STATUS (R)	410
LOOP	410
LOW BATTERY	410
LOW BEAM DUTY CYCLE (%)	323
LOW CLNT LEVEL	410
LOW FUEL INDI	410
LOW FUEL LAMP	481
LOW HOLD INDICATOR	505
LOW HOLD SWITCH	505
LOW HOLD SWT	505
LOW OIL LAMP	411
LOW OIL LEVEL	411
LOW OIL PRESS	411
LOW RAD FAN	366
LOW RPM RANGE	411
LOW SELECTED	411
LOW WASHER FLUID	481
LOW_LAMP	487
LPS (%)	505
LPS(%)	505
LPS(A)	505
LPSB(%)	505
LR WHEEL (MPH)	286
LR_AJAR	323
LR_ID	323

LR_LRN.....	323
LR_MES.....	324
LR_NORM.....	324
LR_REC.....	324
LR_WSPD.....	286
LRAWAKE.....	324
LRB(%).....	506
LRIDPRG.....	324
LRLOBAT.....	324
LRO_PSI.....	324
LT ADP B2S2 (ms).....	411
LT ALPHA (%).....	411
LT ALPHA B2 (%).....	411
LT FUEL TRIM (COUNTS).....	412
LT FUEL TRIM B1 (COUNTS).....	412
LT FUEL TRIM B2 (COUNTS).....	412
LT TRIM B1 (%).....	411
LT TRIM B1(%).....	462
LT TRIM B2 (%).....	411
LT TRIM B2(%).....	462
LT TRIM-1 (%).....	411
LT TRIM-2 (%).....	411
LT TRM AVG1 (%).....	412
LT TRM AVG2 (%).....	412
Lugg Courtesy Sw.....	324
LUSEL SOL MON.....	412
LUSEL SOL OUT.....	412

M

M SHAFT SPD (RPM).....	412
M SHIFT SENSOR (V).....	471
M/C SEN 1.....	287
M/C SEN 2.....	287
M/R OUTPUT.....	286
M/T SHIFT LOCK.....	412
M_DPFE.....	412
M_ENG.....	413
M_IAT.....	413
M_LOAD.....	413
M_PNP.....	413
M_RUN.....	413
M_SOAK.....	413
M_TP.....	413
M_TRIP.....	413
M_VSS.....	413
MAF (g/s).....	413
MAF (gm/Sec).....	413
MAF (Hz).....	413
MAF (V).....	414
MAF PERF TST.....	414
MAF(g/s).....	462
MAF(V).....	414
MAF(V).....	506

MAF=MASS AIR(V)	506
MAF_FAULT	414
MAIN RELAY (FP)	414
MAIN RELAY 1	286
MAIN RELAY 2	287
MAIN RELAY	414
MAIN SW	367
Main Tire	484
MAINRLY	414
MAINSHAFT SPD (RPM)	412
MAINSHAFT SPEED (KPH)(MPH)	506
MALFUNCTION INDICATOR LAMP	414
MAN VAC (kPa)(inHg)	414
MANIFOLD ABSOLUTE PRESSURE SENSOR	414
MANUAL MODE INDICATOR	506
MAP (V)	415
MAP SENSOR	415
MAP SOL V	415
MAP	415
MAP	462
MAP(Hz)	415
MAP/BARO SOL	416
MAP/BARO SOL	416
MAP/BARO SOLENOID	416
MAP/BARO("Hg)	416
MAP/BARO(V)	416
MAP_FAULT	416
MAS CYL PRESS 1	287
MAS CYL PRESS 2	287
MAS CYL PRS 1	287
MAS CYL PRS 2	287
MAT (°C)	416
MAX BAT BLOCK #	470
MAX ENG SPD (RPM)	416
MC DWL (°)	416
MC1	287
MC2	287
MCM STANDBY	417
MCYL CTRL POWER (N-m)	472
MEAS_SSC(A)	506
MEAS_SSD(A)	506
MEAS_SSE(A)	506
MEAS_SSF(A)	506
MFC	417
MFC_FAULT	417
MFCYLM	417
MFPINS	417
MFPLSR	417
MFPLSRF	417
MFPMAX	417
MG1 INVERT TEMP	470
MG1 REV (RPM)	470
MG1 TORQ (N-m)	470

MG1 TORQ EXEC VAL (N-m)	471
MG2 INVERT TEMP	471
MG2 REV (RPM)	471
MG2 TORQ (N-m)	471
MG2 TORQ EXEC VAL (N-m)	471
MIL DIST	417
MIL DIST	463
MIL ON RUN DIST	417
MIL ON RUN DIST	471
MIL ON RUN TIME (MIN)	417
MIL ON RUN TIME	417
MIL ON RUN TIME	471
MIL REQ by DTC	418
MIL STATUS	414
MIL STATUS	471
MIL Status	471
MIL status	471
MIL	414
MIL	463
MIL	506
MILFault	418
MIN BAT BLOCK #	471
MIN. TPS (V)	444
Mirror Fold Sw (Retractable Mirror)	324
Mirror Pos Sw (Down)	324
Mirror Pos Sw (Left)	324
Mirror Pos Sw (Right)	324
Mirror Pos Sw (Up)	324
Mirror Return Sw (Retractable Mirror)	324
Mirror Sel Sw (Left)	325
Mirror Sel Sw (Right)	325
MISFIRE (CMPL)	341
MISFIRE (ENA)	341
MISFIRE CMPL	418
MISFIRE CYCLE (COUNTS)	418
MISFIRE CYCLES	418
MISFIRE CYL 1	418
MISFIRE CYL 2	418
MISFIRE CYL 3	418
MISFIRE CYL 4	418
MISFIRE CYL 5	418
MISFIRE CYL 6	418
MISFIRE CYL 7	418
MISFIRE CYL 8	418
MISFIRE ENA	418
MISFIRE LOAD(g/sec)	419
MISFIRE MARGIN(%)	419
MISFIRE MONITOR	360
MISFIRE MONITOR	419
MISFIRE RPM	419
MISFIRE RPM	419
MISFIRE TEST	419
MISFIRE	418

MISFire.....	418
MISFIRE.....	476
MISFIRED CYL.....	417
MISS CYCLE.....	418
MISS HISTORY 1.....	419
MISS HISTORY 2.....	419
MISS HISTORY 3.....	419
MISS HISTORY 4.....	419
MISS HISTORY 5.....	419
MISS HISTORY 6.....	419
MISS HISTORY 7.....	419
MISS HISTORY 8.....	419
MLN_SW.....	506
M-MODE SIG.....	286
MMODE.....	419
MNL_SW.....	506
Mode Status.....	484
MODE SW RETURN VOLTAGE.....	488
MODE SW SELECTED.....	487
MONITORED COOLANT TEMP.....	481
MONITORED FUEL LEVEL (%).....	481
MONITORED OIL PRESSURE.....	481
MOT BATT TEMP (°).....	419
MOT ECM SIGNAL.....	419
MOTOR A (mA).....	488
MOTOR B (mA).....	488
MOTOR DUTY (%).....	419
MOTOR POS (V).....	420
MOTOR POS STEPS.....	397
MOTOR TH CMD (°).....	399
MOTOR1 TEMP.....	472
MOTOR2 TEMP.....	472
MOTTQLMTX (kgfm).....	420
MOUNT CTRL SOL.....	420
MP_LRN.....	420
MPX-IG Sw.....	319
MT CTRL SOL.....	420
MTR RELAY 1.....	287
MTR RELAY 2.....	287
MTR_CCW.....	488
MTR_CW.....	488
MTSW.....	420
MTSW.....	506

N

N INDICATOR.....	506
N Sw.....	325
N Sw/C Sw.....	325
N SWITCH.....	420
N SWITCH.....	507
NC(0) RPM.....	507
NC(2) RPM.....	507
NCRKMF.....	420

ND WHL SPD	420
NEUT LIGHT	488
NEUT_SW(MTX)	420
NEUT_SW(MTX)	507
NLVL	420
NLVL-1	420
NLVL-2	420
NLVLAD	420
NLVLAD	420
NO. OF MISFIRES	421
NON A/C	421
NON MMODE	421
NOX Gas Sens	300
NP SWITCH	421
NSAFETYSW_4X4M	488
N-SHIFT SOL	507
NSX	421
NTRBCD	421
NUMBER OF BATT BLOCK	472
NUMKEYS	421

O

O/D OFF INDICATOR	507
O/D OFF_HOLD SW	507
O/D SOLENOID	507
O/D SW	507
O/D SWITCH	507
O2 #1 (mV)	422
O2 #2 (mV)	422
O2 (mV)	422
O2 B1-S1 (mV)	422
O2 B1-S1 (V)	422
O2 B1-S1 HTR(%)	423
O2 B1S1 HTR(ma)	423
O2 B1-S1(mV)	463
O2 B1-S2 (mV)	422
O2 B1-S2 (V)	422
O2 B1-S2 HTR(%)	423
O2 B1S2 HTR(ma)	423
O2 B1-S2(mV)	463
O2 B1-S3(mV)	463
O2 B1-S4(mV)	463
O2 B2-S1 (mV)	422
O2 B2-S1 (V)	422
O2 B2-S1 HTR(%)	423
O2 B2S1 HTR(ma)	423
O2 B2-S1(mV)	463
O2 B2-S2 (mV)	422
O2 B2-S2 (V)	422
O2 B2-S2 HTR(%)	423
O2 B2S2 HTR(ma)	423
O2 B2-S2(mV)	463
O2 B2-S3(mV)	463

O2 B2-S4(mV)	463
O2 CROSSCOUNTS	423
O2 HEATER B1-S1	423
O2 HEATER B1-S2	423
O2 HEATER B1-S3	423
O2 HEATER B2-S1	423
O2 HEATER B2-S2	423
O2 HEATER	423
O2 HEATER	476
O2 LR B1S1(ms)	357
O2 LR B2S1(ms)	357
O2 MON B1-S2	423
O2 MON B2-S1	423
O2 MON B2-S2	423
O2 MON	423
O2 RL B1S1(ms)	357
O2 RL B2S1(ms)	357
O2 SENSOR.....	476
O2B1-S1 HTR CMD	424
O2B1-S2 HTR CMD	424
O2B2-S1 HTR CMD	424
O2B2-S2 HTR CMD	424
O2OEVAP	424
O2S #1 STATUS.....	383
O2S #2 STATUS.....	383
O2S (A/FS) (CMPL).....	341
O2S (A/FS) (ENA)	341
O2S (A/FS) HTR (CMPL)	341
O2S (A/FS) HTR (ENA)	341
O2S (A/FS) HTR CMPL.....	424
O2S (A/FS) HTR ENA	424
O2S (A/FS) MONITOR	341
O2S (A/FS) MONITOR	424
O2S (A/FS) MONITOR	424
O2S B1-S1 (V).....	422
O2S B1-S2 (V).....	422
O2S B2-S1 (V).....	422
O2S B2-S2 (V).....	422
O2S FB COND	410
O2S HEATER S1.....	423
O2S(A/FS) MONITOR	360
O2S11 (mV).....	424
O2S11 (V).....	424
O2S11(mA).....	464
O2S11(V).....	463
O2S11_FAULT.....	425
O2S12 (mV).....	424
O2S12 (V).....	424
O2S12(mA).....	464
O2S12(V).....	463
O2S13(mA).....	464
O2S13(V).....	463
O2S14(mA).....	464

O2S14(V).....	463
O2S21 (mV).....	424
O2S21 (V).....	424
O2S21(mA).....	464
O2S21(V).....	463
O2S21_FAULT	425
O2S22 (mV).....	424
O2S22 (V).....	424
O2S22(mA).....	464
O2S22(V).....	463
O2S23(mA).....	464
O2S23(V).....	463
O2S24(mA).....	464
O2S24(V).....	463
O2S31(mA).....	464
O2S32(mA).....	464
O2S32(V).....	463
O2S41(mA).....	464
O2S41(V).....	463
O2S42(mA).....	464
O2S42(V).....	463
OBD CERT	472
OBDSID	425
OCS	297
OCT ADJ	400
OCT ADJ	425
OD CUT #1	351
OD CUT #2	507
OD ENABLED	507
OD INDICATOR.....	507
OD INHIBIT	425
OD OFF LIGHT	425
OD OFF LIGHT	507
OD OFF SW	507
Odo/Trip Sw.....	481
ODOMETER (km)(miles).....	508
ODOMETR	481
OIL LIFE (%).....	425
OIL PRES	425
Oil Press Sw	325
OIL PRESS(V).....	425
OIL_P_L_IC.....	481
OP_SW.....	508
OP_SW_24B	508
OP_SW_LRB.....	508
Open Door Warning.....	325
OPEN MALFUNC	425
OPEN/CLSD LOOP	410
OPN MALFUNC	425
OPS_ST	297
OPSC	425
Optical Sensor (V)	325
OS_SRC.....	508

OSFMFLG	426
OSS(RPM).....	508
OSS_FAULT	508
OUTPUT RPM.....	508
OutShftSp (RPM).....	426
OutShftSp(RPM).....	508
OVER ENG TM (S).....	426
OVERDRIVE SW.....	507
OVERRUN CLUTCH	508
OXS1 TEST.....	426
OXS2 TEST.....	426
OXYGEN SENSOR HEATER.....	423

P

P BUCKLE SW	477
P Door Cty Sw.....	309
P Door Key Sw-UNLOCK	311
P INDICATOR.....	508
P Seat Buckle Sw	310
P/E/HOLD SW	508
P/N Pos Sw	325
P/N POSI SW	509
P/N Position Sw.....	325
P/N SWITCH	426
P/N SWITCH	509
P/N_POS	509
P/S OIL PRESSURE SWITCH.....	393
P/S PRESS SW.....	393
P/S PRESS SW.....	426
P/S PRESS SW.....	509
P/S SIGNAL.....	426
P/W Down/Wireless.....	330
P/W Func/Key.....	329
P/W Func/Remote	329
P/W Lock Sw	325
P/W Up/Wireless	330
P_ABAGR(Ohms).....	297
P_ABAGR2(Ohms).....	297
P_Airbag(Ohms).....	297
P_AirBAG2(Ohms)	297
P_DR.....	481
P_PReTNR(Ohms).....	297
PAB.....	296
PABAGR(Ohms).....	297
Park Brake Sw.....	325
PARK BRAKE SWITCH.....	325
PARK LAMP SWITCH	326
PARK/NEU POS.....	426
PARK_LAMP	325
PARK_SW	325
PARKING BRAKE SW.....	287
Parking Brake Sw	325
ParkNeuPos	426

ParkNeuPos	509
PART LOAD.....	426
PASS BELT.....	296
Pass Door Lock Sw	311
Pass Door Unlock Sw.....	312
PASS IMPACT ID	298
Pass Lock Posit Sw	313
Pass P/W Auto Sw	313
Pass P/W Down Sw.....	313
Pass P/W UP Sw.....	313
Pass PSD Sw	312
PASS/RR DOOR AJAR SW	312
PASSENGER CLASS.....	477
Passing Light Sw	315
PASSING SW	315
Passing Sw	326
Passive Mode	326
PATTERN DRIVE	287
PBSW_C(A).....	298
PCA	509
PCA_FAULT	509
PCAA(A).....	509
PCB	509
PCB_FAULT	509
PCBA(A).....	509
PCF	509
PCF_FAULT	510
PCFA(A)	510
PCG	510
PCG_FAULT	510
PCM IN VTD FAIL	426
PCM RESET.....	427
PCS ACT(AMP).....	510
PCS DES (AMP).....	510
PCS DUTY CYCL(%)	510
PCS DUTY(%).....	510
PCSV DC (%)	510
PD_LOCK.....	326
PD_UNLOCK.....	326
PDL STROKE (V)	288
PDL STROKE 2 (V)	288
PDSW.....	427
PEDAL STROKE (V)	288
PEDAL STROKE 2 (V)	288
PFINH.....	427
PKB SW.....	287
PKBS Sw	325
PLATE_A	488
PLATE_B	488
PLATE_C.....	488
PLATE_D.....	488
PLATE_PWR	488
P-Mirror Memory M1	309

P-Mirror Memory M2.....	309
PMP_MTR.....	288
PMPSTAT.....	288
PNP SW (NSW).....	509
PNP SWITCH.....	427
PNP SWITCH.....	509
PNP SWT.....	509
PNP.....	427
PNP.....	510
PNP_SW.....	509
POS COUNT.....	427
POWER ENRICH.....	342
POWER RQST (W).....	472
POWERSHIFT SW.....	510
PRES UP VSV.....	427
PRESS R SOL.....	427
PRI PRESS (MPa).....	427
PRI SPEED (rpm).....	427
PRK_BRAKE.....	326
PRK_BRK.....	326
PRNDL DISPLAY.....	481
PRNDL STATE.....	481
PRNDL SW.....	427
PROM ID.....	428
PS_AB(Ohms).....	298
PS_BUKL.....	298
PS_PTENS(Ohms).....	298
PSBELTR(Ohms).....	298
PSMOTTRQ.....	428
PSP SWITCH.....	393
PSP SWT.....	393
PSP_SW.....	393
PSP_SW.....	426
PSSOC.....	428
PSTBAT.....	428
PSVBATAL.....	428
PSVBATPT.....	428
PTO STAT.....	464
PULSE CAL ST.....	428
PULSE GEN-A.....	511
PULSE GEN-B.....	511
PULSER CAL STATUS.....	428
PULSER F/B LEARN.....	428
PUMP (V).....	288
PUMP RELAY.....	390
PURGE CUT SOL.....	428
PURGE CUT VSV.....	428
PURGE DENSITY.....	428
PURGE DUTY(%).....	429
PURGE FLOW(%).....	429
PURGE SOL.....	381
PURGE VOL (STPS).....	429
PURGE VSV.....	381

Push Sw	326
PWM_ILLU	326
PWR Condition	326
PWR RESOURCE IB (AMP)	472
PWR RESOURCE VB (V)	472
PWR/ECON SW	511

Q

QCKMIL	429
QXREF	429

R

R BNK UP	383
R DNSTM O2S (V)	422
R Fog Light Sw	327
R FRONT SOLAR SENSOR (V)	321
R FUEL LEVEL (V)	429
R INDICATOR	511
R PROSHAFT (RPM)	487
R Shade Close	326
R Shade Delay Time	327
R SWITCH	429
R SWITCH	511
R UPSTM O2S (V)	422
R WIND DEF SW	429
R_WSPD	288
RAD FAN	429
RAISING PRES RATIO (%)	472
RDEF_RLY	327
RDEF_SW	327
RE CVS VALVE	429
RE VTEC SOL	429
RE VTEC SOL2	430
Rear Def Sw	327
Rear Door Courtesy Sw	309
REAR FOG LAMP SW	327
Rear Hatch Sw	327
Rear Lock Posit Sw	313
REAR MOTOR AMPS	286
REAR MOTOR FBK	286
REAR O2 (mV)	422
REAR O2 HEATERS	430
REAR O2 STATUS	383
REAR O2	383
Rear Shade Sw	327
Rear Washer Sw	327
Rear Wiper Int	327
Rear Wiper On	327
Rear Wiper Stop	327
RED TIMING SOL	511
REDUCE TORQ 1	430
REDUCE TORQ 2	430

REDUCED POWER	430
REF 1(V) STATUS	430
REF 1(V).....	430
REF 2(V) STATUS	430
REF 2(V).....	430
Reg Ctrl Curr(A).....	300
Reg Press Sens.....	300
REGEN COOP	288
REGEN CO-OPRT	288
REGEN EXEC TORQ (N-m)	472
REGEN REQUEST TORQ (N-m).....	472
REGEN TORQ FL (N-m)	288
REGEN TORQ FR (N-m)	288
REGEN TORQ RL (N-m).....	288
REGEN TORQ RR (N-m)	288
Regit ID 1 Code	484
Regit ID 2 Code	484
Regit ID 3 Code	484
Regit ID 4 Code	484
Regit ID 5 Code	484
REL TP (%)	430
REL TP SENSOR (%) (°)	430
REL VTEC SOL.....	429
RELIEF VALVE SOL.....	430
REMOTE_ID.....	327
REMOTES.....	327
REQ TORQUE	430
RESERVOIR SW.....	288
RESET_SW.....	327
Response Time.....	328
RESTART FAN	431
RETARD ACTION	431
RETARD REQUEST.....	431
REV POS SWITCH	511
REV SELECTED	431
REV_SW	511
REVERSE LOCK SOL	431
REVERSE SWITCH	511
Rewipe Function.....	328
Rewipe Time.....	328
RF MOTOR AMPS	286
RF MOTOR FBK	286
RF WHEEL (MPH).....	286
RF_AJAR.....	328
RF_ID	328
RF_LRN.....	328
RF_MES	328
RF_NORM.....	328
RF_PSI	328
RF_REC	328
RF_WSPD	289
RFAWAKE	328
RFDR_SW.....	328

RFIDPRG	328
RFLOWBAT	328
R-FRONT EMB.....	285
R-FRONT SOL	285
RHTURN_IND	329
RIGHT O2.....	383
RIGHT TURN SIGNAL	482
Right Turn Sw	329
RL ABS STATUS	289
RL Door Courtesy Sw	309
RL Lock Posit Sw	313
RL P/W Auto Sw	313
RL P/W Down Sw	313
RL P/W Up Sw.....	313
RL PRS SEN (V)	289
RL SENS RANGE	477
RL SENS VOLTS.....	477
RL SENS WEIGHT(lbs).....	477
RL VSC STATUS	289
RL W/C SEN.....	289
RL W/C SENS (V)	289
RL WHEEL ACCEL (m/s2).....	289
RL WHEEL SPD.....	289
RO2FT1(%)	431
RO2FT2(%)	431
Room Temperature.....	300
RPHRSTR	431
RPM COARSE	431
RPM FINE	431
RPM.....	378
RPM.....	431
RPM.....	464
RPM.....	511
RPMDES	431
RR ABS STATUS.....	289
Rr ACM SOL CURRENT	432
Rr ACM SOL MAX CURRENT	432
Rr ACM SOL MIN CURRENT	432
RR Door Courtesy Sw	309
RR OPERATE TORQ	289
RR P/W Auto Sw	313
RR P/W Down Sw	313
RR P/W Up Sw	313
RR PRS SEN (V).....	289
RR RQST TORQ	289
RR SENS RANGE	477
RR SENS VOLTS	477
RR SENS WEIGHT(lbs)	477
RR VSC STATUS	290
RR W/C SEN.....	290
RR W/C SENS (V).....	289
RR WASHER SW	327
RR WHEEL (MPH)	286

RR WHEEL ACCEL (m/s2)	290
RR WHEEL SPD	290
RR WIPER INT	327
RR WIPER ON	327
RR WIPER STOP	327
RR_AJAR	329
RR_ID	329
RR_LRN	329
RR_MES	329
RR_NORM	329
RR_WSPD	290
RRIDPRG	329
RRLOBAT	329
RRO_PSI	329
RRO_REC	329
RUNTM(SEC)	464

S

S MODE SWITCH	511
S SHIFT SENSOR (V)	473
S SWITCH	432
S SWITCH	511
S/C RELAY	432
S/C SOLENOID	432
S/C TARGET	432
S/C VAC SOL	432
S/C VENT SOL	432
SBLTLMP_IC	482
SBLW RQST	473
SC_ACT_SW	432
SC_SET_LMP	433
SCCS	433
SCCS(V)	433
SCS	514
SCSS	290
Seat Belt Indicator	330
SEAT BELT LAMP	482
SEAT BELT SW	310
Seat Mem 1 Sw	330
Seat Mem 2 Sw	330
Seat Mem Set Sw	330
SEAT_TRAC	298
SEC AIR (CMPL)	341
SEC AIR (ENA)	341
SEC AIR MONITOR	341
SEC AIR MONITOR	360
SEC PRESS (MPa)	433
SEC SPEED (rpm)	433
SECURITY LAMP	482
SEGRP DES(%)	433
SEGRP(%)	433
Select Switch Info	485
Select Switch	485

SELF DIAG LAMP	511
SELTESTDTC	433
SELTESTDTC	482
SENS RANGE INF	477
Sensitivity	330
SERVICE 4WD	482
SET LAMP	433
Set Temp-D	300
Set Temp-P	300
SET VHCL SPD	433
SFT ERROR CODE (\$XX)	512
SFTCMD (H)	433
SFTRIM 1 (%)	433
SFTRIM 2 (%)	433
SHIFT A	513
SHIFT A/1(%)	434
SHIFT B	513
SHIFT B/2(%)	434
SHIFT C/3(%)	434
SHIFT CONTROL	513
SHIFT INDICATOR	434
SHIFT LIGHT	513
SHIFT LOCK SOL	513
SHIFT LOCK	513
SHIFT MAP #	513
SHIFT MAP NUMBER	513
Shift position N	330
Shift position P	330
Shift position R	330
SHIFT POSITION	473
SHIFT SOL A	434
SHIFT SOL A	494
SHIFT SOL A	513
SHIFT SOL A	514
SHIFT SOL B	434
SHIFT SOL B	494
SHIFT SOL B	513
SHIFT SOL B	514
SHIFT SOL C	434
SHIFT SOL C	494
SHIFT SOL C	513
SHIFT SOL D	434
SHIFT SOL D	494
SHIFT SOL E	434
SHIFT SOL E	494
Shift Temp	301
SHIFT/CLUTCH SW	434
SHIFT/CLUTCH SWT	434
ShiftSol1	434
ShiftSol1	513
ShiftSol1Fault	435
ShiftSol1Fault	513
ShiftSol2	434

ShiftSol2	513
ShiftSol2Fault	435
ShiftSol2Fault	513
ShiftSol3	434
ShiftSol3	513
ShiftSol3Fault	435
ShiftSol4	434
ShiftSol4	513
ShiftSol4Fault	435
SHMOTCCLO_4X4M	489
SHMOTCLOC_4X4M	489
SHORT WAVE HIGH	473
SHRTFT1(%)	435
SHRTFT1(%)	464
SHRTFT11(%)	435
SHRTFT11(%)	465
SHRTFT12(%)	435
SHRTFT12(%)	465
SHRTFT13(%)	465
SHRTFT14(%)	465
SHRTFT2(%)	435
SHRTFT2(%)	464
SHRTFT21(%)	435
SHRTFT21(%)	465
SHRTFT22(%)	435
SHRTFT22(%)	465
SHRTFT23(%)	465
SHRTFT24(%)	465
SHRTFT3(%)	464
SHRTFT31(%)	465
SHRTFT32(%)	465
SHRTFT4(%)	464
SHRTFT41(%)	465
SHRTFT42(%)	465
SIDE G	290
SLAFL CUR	290
SLAFL CURR (A)	290
SLAFR CUR	290
SLAFR CURR (A)	290
SLARL CUR	290
SLARL CURR (A)	290
SLARR CUR	290
SLARR CURR (A)	290
SLCT LVR POSI	291
SLIP ADPT DC (%)	489
SLIP INDI LAMP	291
SLIP LAMP	291
SLIP REV (rpm)	435
SLIP_DES	514
SLIPPAGE (RPM)	486
SLN SOLENOID	514
SLRFL CUR	291
SLRFL CURR (A)	291

SLRFR CUR	291
SLRFR CURR (A).....	291
SLRRL CUR	291
SLRRR CUR.....	291
SLT SOLENOID.....	514
SLU SOLENOID	514
SM SHIFT SENSOR (V).....	473
SMC1.....	291
SMC2.....	291
SMCOIL A	435
SMCOIL B	435
SMCOIL C	435
SMCOIL D	435
SNOW MODE INDICATOR	514
SNOW MODE SW	291
SNOW MODE SWITCH	514
SO2S B2 H CUR (mA)	435
SO2S H CUR (mA).....	436
SOAK TIME (min).....	436
SOC (%)	436
SOC (%)	473
SOFTWARE ID	489
SOL A ACT	493
SOL A CMD.....	493
SOL B ACT	493
SOL B CMD.....	493
SOL C ACT.....	493
SOL C CMD.....	493
SOL SUPPLY (V).....	514
SOL V	436
Solar Sens-D	301
Solar Sens-P	301
SOLMON1	436
SOLMON2.....	436
SOLMON3.....	436
SPARK ADV (°)	400
SPARK ADV(°)	436
SPARK ADV(°)	514
SPARK ADVANCE.....	400
SPARKADV(°)	465
SPD (NC).....	436
SPD (NC0).....	436
SPD (NC2).....	436
SPD (NC3).....	436
SPD (NT)	436
SPD SEN FL.....	292
SPD SEN FR	291
SPD SEN RL	292
SPD SEN RR.....	292
SPD TEST	437
SPD(SP2) KPH.....	436
SPD(SP2) MPH.....	436
Speed Meter	482

Speed Mode	330
SPEED RATIO.....	515
SPK ADV (°)	400
SPK ADV (°BTDC)	400
SPK ADV(°BTDC)	436
Sport A/T Sw.....	330
SPR_ID.....	330
SPRKADV(°).....	436
SRC_CAN	437
SRS LAMP	297
SS MODE SWITCH.....	515
SS MODE SWT	515
SS SHIFT SENSOR (V)	473
SS SHIFT SENSOR (V)	473
SSA_SS1.....	515
SSA_SS1(%)	515
SSA_SS1_FAULT.....	515
SSB_SS2.....	515
SSB_SS2(%)	515
SSB_SS2_FAULT.....	515
SSC	292
SSC_SS3	515
SSC_SS3(%).....	515
SSD_SS4	515
SSE_SS5.....	515
SSF(A).....	516
SSF_SS6.....	515
SSG(A)	516
ST ALPHA (%).....	437
ST ALPHA B2 (%)	437
ST FUEL TRIM (COUNTS)	437
ST FUEL TRIM B1 (COUNTS)	437
ST FUEL TRIM B2 (COUNTS)	437
ST TRIM (%).....	437
ST TRIM B1 (%)	437
ST TRIM B1(%)	465
ST TRIM B2 (%)	437
ST TRIM B2(%)	465
ST TRIM(%).....	465
ST TRIM-1 (%)	437
ST TRIM-2 (%)	437
ST TRM AVG1 (%)	438
ST TRM AVG2 (%)	438
ST1	438
STA SIGNAL.....	438
START CLNT (°).....	438
START ENRICH	438
START ETC: (°)	438
START IAT (°).....	438
START RPM	439
START SIG	516
STARTER CONTROL.....	439
STARTER CTRL.....	439

STARTER RELAY	439
STARTER SIG	438
STARTER SWITCH	439
STARTER SWT	439
STARTER	438
STEERING ANG (°)	292
STEERING ANGLE (°)	292
STEERING SEN	292
STEERING WHEEL CONTROL(V)	331
STEERING WHEEL SW PWR	331
STOP LAMP SW	292
STOP LAMP SW	439
STOP LIGHT SW	292
Stop Light Sw	331
Stop Light Transistor	331
STR ANGLE	292
Str Unlock Sw	331
STROKE SEN 1	292
STSW1	331
STSW2	331
SUB BRAKE SWITCH	439
SVC 4WD LAMP	489
SVSM	439
SVSOUT	439
SVSP	439
SWITCH STATE	439
SYS GUARD	439
SYS GUARD	439
SYSFAIL	439

T

TAC MTR CMD(%)	439
TAC PCT(%)	465
TAC/PCM COMM FLT	440
Tacho Meter	482
TACHO_GAUGE	440
TACM RELAY	440
Tail Cancel Sw	331
Tail Cancel	482
Tail Lamp	331
Tail Light Sig	331
Tail Light Sw	331
Tail Light Transistor	331
TAIL_AJAR	331
TANK BYP VSV	440
TANK PRES	440
TANK PRES(V)	440
TANK PRESS (V)	440
TANK PRS (kPa)(inHg)(mmHg)	440
TANK TEMP (°)	440
TARG LINE	440
TARG LINE	516
TARGET A/F (V)	339

TARGET ENG SPD (RPM).....	473
TARGET ENG SPD	440
TARGET TH VALVE	440
TARGET TH VLV (ETCS)(°)	440
TARGIDL (RPM).....	441
TAT TERMINAL	441
TC/TE1	441
TC_SLIP(RPM).....	516
T-CASE RATIO	516
TCC (%).....	441
TCC BRAKE SW	516
TCC COMMAND	441
TCC COMMAND	516
TCC DUTY SOL CKT STATUS	491
TCC DUTY(%).....	516
TCC EFFICIENCY	517
TCC ENAB SOL CKT STATUS	491
TCC ENABLE SOL.....	517
TCC ENABLED	516
TCC ENABLED	517
TCC GROUNDED	517
TCC PWM ENABLED.....	516
TCC RELEASE	517
TCC SLIP(RPM).....	517
TCC SOL (%)	517
TCC SOL.....	517
TCC SOL(%)	441
TCC SOLENOID.....	516
TCC(%).....	518
TCC/CC BRAKE SW	441
TCC_FAULT	518
TCC_MES(A).....	518
TCCA(V).....	518
TCCC.....	516
TCCC(%).....	518
TCCFault	441
TCCFault	518
TCCMACT (RPM).....	441
TCCMACT(RPM).....	518
TCIL.....	518
TCIL_FAULT	518
TCILFault.....	441
TCILFault.....	518
TCINH.....	441
TCS ACTIVE	518
TCS FUEL-CUT.....	442
TCS INH	442
TCS OFF LAMP	292
TCS OFF SW	292
TCS STANDBY.....	442
TCS	518
TC-SDL.....	441
TCS-PGM-FI.....	442

TEMP_GAUGE.....	442
TEN TERMINAL	442
TEST MODE.....	293
TEST	442
TFP SW	518
TFP SWITCH A	519
TFP SWITCH B	519
TFP SWITCH C	519
TFT (°)	496
TFT	519
TFT(V)	519
TFT_FAULT	519
TGT VLV TMNG(°)	442
THIDLL (°)	442
THOP(%).....	519
THROTL IDL POS	442
THROTL MTR CLSD DUTY(%)	442
THROTL MTR OPN DUTY(%)	442
THROTL POS (%)	442
THROTL POS (%)	443
THROTL SSR #1 AD (V).....	443
THROTTLE (%).....	443
THROTTLE (°).....	443
THROTTLE MTR (%)	443
THROTTLE MTR AMPS.....	443
THROTTLE MTR	443
THROTTLE POS	443
THROTTLE POSITION SENSOR (V)	444
THROTTLE SW.....	444
THROTTLE SW.....	446
THROTTLE SW.....	519
THROTTLE VLV (°)	444
THROTTLE(%)	465
THROTTLE(%)	519
ThrPosMODE	444
ThrPosMODE	520
THRTL CMD VAL(V).....	444
THRTL CMND VAL.....	444
THRTL LEARN VAL(V).....	444
THRTL LEARN VAL(V).....	445
THRTL MTR CLOSE (%)	445
THRTL MTR CLOSE (%)	445
THRTL MTR OPEN (%)	445
THRTL MTR OPN (%)	445
THRTL POS1 (V).....	445
THRTL POS2 (%).....	445
THRTL POS2 (V).....	445
THRTL RELAY.....	445
THRTL REQ POS (V)	445
THRTL REQ POS(V).....	445
THRTL SSR #1 (V).....	446
THRTL SSR #1 (V).....	446
THRTL SSR #1 AD(V).....	446

THRTL SSR #2 (V).....	446
THRTL SSR #2 (V).....	446
TIME DTC CLEAR.....	446
TIME DTC CLEAR(MIN).....	473
TIME ON (HOURS).....	298
TIME ON.....	446
TIME.....	446
TIMESSES.....	446
TIMING (°BTDC).....	400
Tire Press 1(gauge).....	485
Tire Press 2(gauge).....	485
Tire Press 3(gauge).....	485
Tire Press 4(gauge).....	485
Tire Press 5(gauge).....	485
Tire Temp 1.....	485
Tire Temp 2.....	485
Tire Temp 3.....	485
Tire Temp 4.....	485
Tire Temp 5.....	485
TMBLVL.....	446
TNSMT_CMD.....	332
TNSMTR_ID.....	332
TORQ DELIV(Nm).....	520
TORQUE.....	446
TORQUE.....	520
TOTAL ADV (°).....	400
TOTAL WEIGHT(lbs).....	477
TP (%).....	443
TP (%).....	447
TP (V).....	444
TP 1&2 AGREE.....	447
TP A-B (°).....	447
TP B(%).....	466
TP C(%).....	466
TP MODE.....	520
TP R(%).....	447
TP R(%).....	466
TP SENSOR (%).....	443
TP SENSOR (V)(%).....	447
TP SENSOR-A (V).....	447
TP SENSOR-B (V).....	447
TP SWITCH.....	447
TP(%).....	466
TP(%).....	520
TP(V).....	447
TP(V).....	520
TP=TPS (V).....	447
TP=TPS(V).....	520
TP_FAULT.....	447
TP_FAULT.....	520
TP_MODE.....	447
TP_PER(%).....	520
TP_REL(%).....	447

TP1(%)	448
TP1(V)	448
TP2(%)	448
TP2(V)	448
TPCT (V)	448
TPCT	448
TPCT(V)	448
TPCT(V)	520
TPS (%)	443
TPS (ECM)	444
TPS (ETS)	444
TPS (V).....	444
TPS 1 (V).....	444
TPS 1&2 AGREE.....	447
TPS 2 (V).....	444
TPS FROM EFI	378
TPS(%)	448
TPS(%)	520
TPS(V).....	448
TPS(V).....	520
TPS/8.....	520
TPS1 (%).....	443
TPS1 (V).....	444
TPS1 LRN MIN(V)	448
TPS2 (%).....	443
TPS2 (V).....	444
TPS2 LRN MIN(V)	448
TQR/ECT	449
TR SW A/B/C/P	521
TR SW(A)	521
TR SW(B)	521
TR SW(C)	521
TR SW(P)	521
TR SWITCH.....	521
TR.....	521
TR_FAULT	522
TR_POS	522
TR_SNSOR(V)	522
TR_V	449
TRAC BRK STATUS.....	293
TRAC STATUS	293
TRACTION CTRL.....	448
TRACTION SIGNAL	448
TRAK_SW	298
TRANS CTRL LAMP	522
TRANS FLUID (°)	496
TRANS SLIP CNT	522
Trans Status.....	485
TRANS TEMP (°).....	496
TransRange(V)	522
TransRange_ACTUAL GEAR.....	522
TransRange_D	522
TRD	522

TRIM B1-S1 (%)	437
TRIM B1-S1 (%)	466
TRIM B1-S2 (%)	437
TRIM B1-S2 (%)	466
TRIM B1-S3 (%)	466
TRIM B1-S4 (%)	466
TRIM B2-S1 (%)	437
TRIM B2-S1 (%)	466
TRIM B2-S2 (%)	437
TRIM B2-S2 (%)	466
TRIM B2-S3 (%)	466
TRIM B2-S4 (%)	466
TRIP CounT	449
TRIP CouNT	522
TRIP ODOMETER A	482
TRIP ODOMETER B	482
TRIP RESET SWITCH	482
TRIP	449
TRIP	522
TRIP_CNT	449
TRIP_CNT	522
TRIP_SW	449
TRIP_SW	482
TRL	523
TrnAxleRLRN	523
TrnCtrlIndLamp	449
TrnCtrlIndLamp	523
TrnCtrlSw	449
TrnCtrlSw	523
TrnFluidTmp (V)	449
TrnFluidTmp(V)	519
TrnFluidTmp(V)	523
TRR	523
TRS	523
TRUNK BTN/SIG	332
Trunk Cyl Sw	332
TRUNK KEY SW	332
Trunk Key Unlock	332
Trunk Lid Operation	332
Trunk Main Sw	332
Trunk Opener Monitor	332
Trunk Opener Sw	332
TRUNK OPN MNTR	332
TRUNK OPNR SW	332
Trunk/Back Door Open Sw	332
TRUNK_AJAR	332
TRVL AFTER MIL	449
TS_SRC	523
TSLIPRAT(1000:1)	523
TSS(RPM)	523
TSS_FAULT	523
TurbSpds (RPM)	450
TurbSpdS(RPM)	523

Turn Left Sw	323
Turn Right Sw	329
TWC TEMP	450

U

UN BUTTON ON	333
UN BUTTON/SIG	333
UNLK SW AS	333
UNLK SW DR	333
Unlock w/KOEO & Park	333
Unlock2 Operation	333
UP SHIFT SWITCH	523
UP SHIFT SWT	523
Up/Door Key	312
UP_SW	523
UPLVR	450
UPSHIFT LAMP	483

V

V/R OUTPUT	293
VAC CUT BYPASS	450
VACUUM PMP	450
VAF RESET SIG	450
VAPOR PRES CALC	450
VAPOR PRES CALC	450
VAPOR PRES VSV	450
VAPOR PRESS PUMP	456
VAPOR PRESS TANK	450
VARI INTAKE VSV	450
VBAT(V)	451
VBATT (V)	298
VBATT	489
VBATT(V)	523
VDC OFF LAMP	293
VDC OFF SW	293
VEH LOAD(%)	451
VEH SPEED	293
VEH SPEED	451
VEH SPEED	524
VEH SPEED(KPH)	466
VEH SPEED(MPH)	466
Vehicle Spd Sig	333
VEHICLE SPD	293
VEHICLE SPD	474
VEHICLE SPD	474
Vehicle Speed	333
VEHICLE SPEED	451
VEHICLE SPEED	483
VENT CONT VALVE	451
VH (V)	474
VHCL SPD CUT	451
VHCL SPEED SEN	333

VIAS S/V.....	451
VL (V)	474
VLV_CTR.....	293
VMF FAN VOLTAGE.....	474
VOLT M/C SEN	293
VOLT M/C SENS 2	293
VOLT STROK SEN (V).....	294
VOLT STROK SEN 2 (V).....	294
VPoWeR(V).....	524
VPS SOL	451
VPS STATUS.....	451
VPWR(V).....	466
VPWR(V).....	524
VPWR=BATT(V).....	524
VREF(V).....	452
VRIS SOL VALVE.....	452
VRIS SOL VLV 1	452
VRIS SOL VLV 2	452
VRISV1.....	452
VRISV2.....	452
VSA REQ TH (°).....	452
VSC EQUIPED	294
VSC WARN LAMP.....	294
VSC/TRC OFF SW.....	294
VSS (METER)	524
VSS	452
VSS	524
VSS(KPH).....	466
VSS(MPH).....	466
VSS_4X4M.....	489
VSS_FAULT	452
VSS_TPM.....	333
VT ACT2(°).....	452
VT_ACT1(°).....	452
VT_DIFF1(°).....	452
VT_DIFF2(°).....	452
VT_DUTY1(%).....	452
VT_DUTY2(%).....	453
VTC SOL DUTY (%).....	453
VTC STATUS.....	453
VTD AUTOLRN TMR	453
VTD F_DISUNTIL.....	453
VTD FAIL ENABLD.....	453
VTD FUEL DISABL	453
VTD FUEL ENABLE	453
VTD FUEL	453
VTD PASSWORD OK	454
VTEC INFORMATION	454
VTEC PRES SW B1	454
VTEC PRES SW B2.....	454
VTEC PRES SW	454
VTEC PS SW	454
VTEC SOL 1.....	454

VTEC SOL 2.....	454
VTEC SOL B1	454
VTEC SOL B2	454
VTEC SOL.....	454
VVT AIM ANGL #1(%).....	454
VVT AIM ANGL #2(%).....	454
VVT CHNG ANGL #1(°)	455
VVT CHNG ANGL #2(°)	455
VVT CHNG ANGL#1 (°)	454
VVT CHNG ANGL#2 (°)	455
VVT CONTROL	455
VVT CTRL B1.....	455
VVT CTRL B2.....	455
VVT EX CHG ANG1 (°)	455
VVT EX CHG ANG1(°)	455
VVT EX CHG ANG2 (°)	455
VVT EX CHG ANG2(°)	455
VVT EX HOLD B1(%).....	455
VVT EX HOLD B2(%).....	456
VVT EX OCV D B1(%)	456
VVT EX OCV D B2(%)	456
VVT OCV DUTY B1(%).....	456
VVT OCV DUTY B2(%).....	456
VVTL AIM ANGL#1 (%).....	456
VVTL AIM ANGL#2 (%).....	456

W

WAC=WOT A/C.....	456
WAC=WOT A/C.....	524
WAC_FAULT	456
WARM UPS CYC DTC CLEAR	456
WARM UPS CYC DTC CLEAR	474
WARM UPS	466
WARMUP ENRICH.....	438
WARM-UPS W/O EMISSION FAULTS.....	457
WARM-UPS W/O NON-EMISSION FAULTS	457
Warn By Glass Snsr	333
Warn By Horn	334
WARN_1.....	333
WARN_2.....	333
WARN_3.....	333
WARN_4.....	333
WARN_5.....	333
WASH_FRT	334
WASH_SW	315
WASHPUMP.....	334
WASHRLY	334
WASTEGATE SOL	457
WHEEL SPD FL	286
WHEEL SPD FL	294
WHEEL SPD FR.....	286
WHEEL SPD RL.....	286
WHEEL SPD RL.....	294

WHEEL SPD RR	286
WHEEL SPD RR	294
WHL SPD FL	294
WHL SPD FR	294
WHL SPD RL.....	294
WHL SPD RR	294
WIDE OPEN THROT.....	457
WIN CTRL POWER (W).....	474
WIN.....	474
WIP Sw (+1)	334
WIP Sw (2S).....	334
WIP Sw (C1).....	334
WIP Sw (SM).....	334
WIP Sw.....	334
Wireless Buzzer Response	334
Wireless Door Lock Operation.....	334
WOT SW	457
WOUT CTRL POWER (W).....	474
WOUT.....	474
WPFAS _T _FRT	334
WPINT_FRT	334
WPINT_REAR	335
WPRLY_LOW.....	334
WPRLY_REAR	334
WPRPRKSTS.....	335

X

XFER CASE LCKD.....	489
---------------------	-----

Y

YAW RATE SEN	295
YAW RATE SENS 1.....	295
YAW RATE SENS 2.....	295
YAW RATE VALUE	295
YAW RATE	294
YAW RATE	294
YAW ZERO VALUE	295

Z

ZERO DECELERAT (m/s ²)	295
ZERO STEERING	295
ZERO YAW RATE 2	295
ZERO YAW RATE	295
ZRD _{TY}	457

Antilock Brake System (ABS) Parameters

This section defines data parameters available from the antilock brake systems (ABS). To find the description of a specific parameter, locate the parameter name in the index and then go to the listed page.

1 SYS BRAKE

Range: _____ **BEFORE, DURIN**

Indicates the 1 Sys Brake. DURING = During operation.

2 FRAMES

Range: _____ **YES/NO**

Indicates when there are two or more frames for freeze frame data.

- YES when there are two or more frames for freeze frame data

4WD ACTIVE

Range: _____ **YES/NO**

Indicates the operating status of the 4WD system on models with a VCM and a 4WAL or RWAL system. It reads:

- YES when the VCM disables antilock braking
- NO under normal operating conditions

ABS BATT (V)

ABS IGN (V)

Range: _____ **0.0 to 13.50 V**

Indicates the switched (ABS IGN) and unswitched (ABS BATT) voltages to the ABS ECM.

ABS LAMP

Range: _____ **ON/OFF/FLSH**

Indicates the current status of the ANTILOCK/ABS lamp on the instrument panel:

- OFF means the lamp should be off and ABS is fully operational.
- FLSH means the lamp is flashing due to a detected fault, ABS remains operational.
- ON means the lamp is continuously on due to a detected fault, ABS operation is limited. If the fault affects the front ABS, the rear ABS operates with the front brakes in a non-ABS condition. If the fault affects the rear ABS or other critical parts of the system, ABS is completely disabled. Brakes at all four wheels operate in a basic non-ABS mode.

If the reading does not match the condition of the warning lamp on the instrument panel, a lamp circuit fault may exist.

ABS SRI STATUS

Range: _____ **ON/OFF**

Indicates the status of the ABS service repair lamp, reads ON when ABS service is needed.

ABS STOP

Range: _____ **YES/NO**

Indicates whether the ABS has been activated during the current braking event. It only reads YES when ABS is activated during braking, and reads NO at all other times.

ABS_VOLT

Range: _____ **0.0 to 16.0 V**

Indicates the battery positive voltage.

ABSLAMP
ABS WARN LAMP
 Range: _____ **ON/OFF**

Indicates the ABS warning light status.

- ON indicates the warning light is on
- OFF indicates the warning light is off

ACC PRESS SENS
ACC PRESS SENS1 (V)
 Range: _____ **0.0 to 5.0 V**

Indicates the accumulator pressure sensor. Specified value is 3.2 to 4.0 V.

ACC SEN
 Range: _____ **NORM, OPEN**

Indicates the accumulator pressure sensor open status.

NORMAL when in normal condition

ACCELERATOR (%)
 Range: _____ **0% to 128%**

Indicates the accelerator opening angle.

- 0% when the accelerator pedal is released

ACCEL POS SIG
 Range: _____ **0% to 100%**

Indicates throttle position. 0% when not pressed, 1 to 100% when pressed.

ASCD SIGNAL
 Range: _____ **OFF/ON**

Indicates ASCD signal status. ON indicates the signal is on, OFF indicates signal is off.

BOO
 Range: _____ **ON/OFF**

Indicates the brake on and off status.

BRAKE LAMP
 Range: _____ **ON/OFF or CKT OPEN**

Indicates the status of the brake lamp circuits, it reads ON when the circuit is closed and the brake lights are on. Compare this parameter to the BRAKE LAMP CMD parameter.

BRAKE LAMP CMD
 Range: _____ **ON/OFF**

Indicates the commanded ABS control module output signal to the brake lamps.

BRAKE SW
 Range: _____ **ON/OFF, OPEN/CLSD, or ON/OFF/CKT OPEN**

Indicates the status of the brake switch on most vehicles, it reads:

- OPEN when the brakes are applied
- CLSD when the brake pedal is released

On some vehicles, the ABS module monitors the condition of the brake switch circuit. A CKT OPEN reading means the module detected an open circuit, which may result in the ABS being fully or partially disabled.

BRAKE WARN LAMPRange: _____ **ON/OFF**

Indicates the brake warning light status.

- ON when the warning light is on
- OFF when the warning light is off

BUZZERRange: _____ **ON/OFF**

Indicates the skid control buzzer status.

- ON when the buzzer is on
- OFF when the buzzer is off

CCNTABSRange: _____ **0 to 255**

Indicates ABS continuous codes.

DECELE SENRange: _____ **NORM, OPEN**

Indicates the decelerator sensor open status.

- NORMAL when in normal condition

DECELERAT SEN (m/s²)**DECELERAT SEN 2 (m/s²)**Range: _____ **-18.52 to 18.39 m/s²**

Indicates the decelerator sensor 1. Reading changes when vehicle is bounced.

DTC_CNTRange: _____ **0 to 255**

Indicates the number of trouble codes set.

ECB MTR RELAYRange: _____ **ON/OFF**

Indicates the ABS motor relay status.

ECB MTR RELAY 2Range: _____ **ON/OFF**

Indicates the ABS motor relay 2 status.

ECB RELAYRange: _____ **ON/OFF**

Indicates the ABS main relay status.

ECB RELAY 2Range: _____ **ON/OFF**

Indicates the ABS main relay 2 status.

ENABLE RELAYRange: _____ **ON/OFF**

Indicates the state of the ABS control module output signal to the enable relay, it reads ON when the relay is powered. This relay provides battery voltage and current to the ABS control module and the electromagnetic brakes (EMBs).

ENG OIL TMP

Range: _____ 0 to 100°C (0 to 212°F)

Indicates temperature of engine oil. More than 70°C (158°F) after warmup.

EX VTC DTY B1

Range: _____ 0 to 70%

Indicates control value of the exhaust valve timing control magnet retarder. Angle becomes larger as value increases. After warmup, shift lever in N, A/C off, and no load, -0 to 2% at idle, approximately 0 to 70% above 1500 RPM.

EX VTC DTY B2

Range: _____ 0 to 70%

Indicates control value of the exhaust valve timing control magnet retarder. Angle becomes larger as value increases. After warmup, shift lever in N, A/C off, and no load, -0 to 2% at idle, approximately 0 to 70% above 1500 RPM.

EXH V/T LEARN

Range: _____ YET/CMPLT

Indicates condition of Exhaust Valve Timing Control Learning. YET indicates learning has not been performed yet, CMPLT indicates learning has already been performed successfully.

EXH/V TIM-B1

Range: _____ -5° to 30°

Indicates angle of exhaust camshaft retarded angle. After warmup, shift lever in N, A/C off, and no load, -5 to 5° at idle, approximately 0 to 30° above 1500 RPM.

EXH/V TIM-B2

Range: _____ -5° to 30°

Indicates angle of exhaust camshaft retarded angle. After warmup, shift lever in N, A/C off, and no load, -5 to 5° at idle, approximately 0 to 30° above 1500 RPM.

FL ABS STATUS

Range: _____ ON/OFF

Indicates the front left wheel ABS control status.

- ON during the control

FL PRS SEN (V)

Range: _____ 0.0 to 5.0 V

Indicates the front left pressure sensor.

- 0.3 to 0.9 V when the brake pedal is released

FL VSC STATUS

Range: _____ ON/OFF

Indicates the front left wheel VSC control status.

- ON during the control

FL W/C SEN

Range: _____ NORM, OPEN

Indicates the front left wheel cylinder pressure sensor open detection.

- NORMAL when in normal condition

FL W/C SENS (V)

Range: _____ 0.0 to 5.0 V

Indicates the front left wheel cylinder pressure sensor.

- 0.3 to 0.9 V when the brake pedal is released

FL WHEEL ACCEL (m/s²)

Range: _____ -200.84 m/s² to 199.27 m/s²

Indicates the front left wheel rate of acceleration.

FL WHEEL SPD

Range: _____ 0 mph to 202 mph or 0 km/h to 326 km/h

Indicates the front left wheel speed sensor reading. Actual wheel speed similar speed as indicated on the speedometer.

FLUID LEV SW

Range: _____ OFF/ON

Indicates brake fluid level. ON indicates fluid level is low, OFF indicates fluid level is sufficient.

FORWARD & REAR G (m/s²)

Range: _____ min: -25.11 m/s² to max: 24.91 m/s²

Indicates the forward and rearward G force.

FPCM

Range: _____ LOW/HI

Indicates the control condition of the fuel pump control module. Reads HI when cranking, and reads LOW when running at idle and the engine temperature is above 10°C (50°F).

FR ABS STATUS

Range: _____ ON/OFF

Indicates the front right wheel ABS control status.

- ON during the control

FR OPERATE TORQ

Range: _____ 0 N-m to 4,080 N-m

Indicates the front regenerative operation torque.

FR PRS SEN (V)

Range: _____ 0.0 to 5.0 V

Indicates the front right pressure sensor.

- 0.3 to 0.9 V when the brake pedal is released

FR RQST TORQ

Range: _____ 0 N-m to 4,080 N-m

Indicates the front regenerative request torque.

FR VSC STATUS

Range: _____ ON/OFF

Indicates the front right wheel VSC control status.

- ON during the control

FR W/C SEN

Range: _____ NORM, OPEN

Indicates the front right wheel cylinder pressure sensor open detection.

- NORMAL when in normal condition

FR W/C SENS (V)

Range: _____ 0.0 to 5.0 V

Indicates the front right wheel cylinder pressure sensor.

- 0.3 to 0.9 V when the brake pedal is released

FR WHEEL ACCEL (m/s²)

Range: _____ -200.84 m/s² to 199.27 m/s²

Indicates the front right wheel rate of acceleration.

FR WHEEL SPD

Range: _____ 0 mph to 202 mph or 0 km/h to 326 km/h

Indicates the front right wheel speed sensor reading. Actual wheel speed similar speed as indicated on the speedometer.

G-SENSOR (V)

Range: _____ 0.0 to 5.0 V

Indicates the output voltage signal from the centrifugal force (G-force) sensor as the vehicle decelerates.

HV COMM

Range: _____ NORM, OPEN

Indicates the HV communication open detection.

- NORMAL when in normal condition

IDLE SW

Range: _____ ON/OFF

Indicates the main idle switch.

- ON when the accelerator pedal is released
- OFF when the accelerator pedal is depressed

IG VOLTAGE

Range: _____ NORM, HIGH, LOW

Indicates the ECU power supply voltage.

- HIGH when 9.5 V or over
- NORM when 9.5 V
- LOW when below 9.5 V

L-FRONT EMB**R-FRONT EMB**

Range: _____ ON/OFF

Indicates the present state of the ABS control module output signal to the left and right front electromagnetic brakes (EMBs). Reads ON when the ABS control module activates the EMBs during front wheel ABS operation.

L-FRONT SOL**R-FRONT SOL**

Range: _____ ON/OFF

Indicates the present state of the ABS control module output signal to the left and right front solenoids. Reads ON when solenoids are energized during front wheel ABS operation.

LATERAL G (m/s²)

Range: _____ min: -25.11 m/s² to max: 24.91 m/s²

Indicates the lateral G force.

LF MOTOR AMPS
RF MOTOR AMPS
REAR MOTOR AMPS

Range: _____ **0 to 20 A**

Indicates the output current the ABS control module is applying to the motors as amperes. The reading is a positive value when the motors are driven forward, and negative (-) when the motors are driven in reverse. During motor operation, this value should be higher than the current displayed by the MOTOR FBK parameters.

LF MOTOR FBK
RF MOTOR FBK
REAR MOTOR FBK

Range: _____ **0 to 20 A**

Indicates the feedback current measured by the ABS control module from the drive motors. During motor operation, this value should be lower than the current being displayed by the MOTOR AMPS parameters.

LF WHEEL (MPH)
RF WHEEL (MPH)
RR WHEEL (MPH)
WHEEL SPD FL
WHEEL SPD FR
WHEEL SPD RL
LR WHEEL (MPH)
WHEEL SPD RR

Range: _____ **0 to vehicle max.**

Indicates the speed of the individual wheels, which is calculated by the ABS control module from the input voltage signals of the wheel speed sensors.

Wheel speeds should be equal to each other and to vehicle speed as the vehicle is driven in a straight line without braking. Wheel speeds vary when turning, and may vary during braking without antilock operations. During ABS braking, wheel speeds should remain close to equal.

LF_WSPD

Range: _____ **0 to vehicle max.**

Indicates the left front wheel speed sensor.

LR_WSPD

Range: _____ **0 to vehicle max.**

Indicates the left rear wheel speed sensor.

M/R OUTPUT

Range: _____ **OFF/ON**

Indicates status of actuator motor and motor relay. ON indicates motor and motor relay are active, OFF indicates motor and motor relay are inactive.

M-MODE SIG

Range: _____ **OFF/ON**

Indicates the automatic transmission (A/T) manual mode status. Reads OFF when not in A/T manual mode, and ON when in A/T manual mode.

MAIN RELAY 1

Range: _____ **ON/OFF**

Indicates the main relay 1 for ECB. Reads ON in operating mode when ECB is active.

MAIN RELAY 2Range: _____ **ON/OFF**

Indicates the main relay 2 for ECB. Reads ON in operating mode when ECB is active.

MAS CYL PRESS 1**MAS CYL PRS 1**Range: _____ **0.0 to 5.0 V**

Indicates the master cylinder pressure sensor 1 reading. Voltage increases when the brake pedal is depressed. Readings should be from 0.3 to 0.9 V when the brake pedal is released.

MAS CYL PRESS 2**MAS CYL PRS 2**Range: _____ **0.0 to 5.0 V**

Indicates the master cylinder pressure sensor 2 reading. Voltage increases when the brake pedal is depressed. Readings should be from 0.3 to 0.9 V when the brake pedal is released.

MC1Range: _____ **ON/OFF**

Indicates the MC1 status. Reads ON when in operating mode, reads OFF at all other times.

MC2Range: _____ **ON/OFF**

Indicates the MC2 status. Reads ON when in operating mode, reads OFF at all other times.

M/C SEN 1Range: _____ **NORM, OPEN**

Indicates whether and open exists on the master cylinder pressure sensor 1 circuit. Reads OPEN only when an open circuit is detected, reads NORM (normal) at all other times.

M/C SEN 2Range: _____ **NORM, OPEN**

Indicates whether and open exists on the master cylinder pressure sensor 2 circuit. Reads OPEN only when an open circuit is detected, reads NORM (normal) at all other times.

MTR RELAY 1Range: _____ **ON/OFF**

Indicates the motor relay 1 status.

MTR RELAY 2Range: _____ **ON/OFF**

Indicates the motor relay 2 status.

PARKING BRAKE SW**PKB SW**Range: _____ **ON/OFF**

Indicates the parking brake switch status. Reads ON when the parking brake is applied, and OFF when the parking brake is released.

PATTERN DRIVERange: _____ **ON/OFF**

Indicates that a pattern drive is under enforcement. Reads ON only during pattern drive operation, and OFF during normal operating conditions.

PDL STROKE (V)**PEDAL STROKE (V)**Range: _____ **0.0 to 5.0 V**

Indicates the signal voltage of the brake pedal stroke sensor. Typical readings range from 0.7 to 1.3 V when the brake pedal is released.

PDL STROKE 2 (V)**PEDAL STROKE 2 (V)**Range: _____ **0.0 to 5.0 V**

Indicates the signal voltage of the brake pedal stroke sensor 2. Typical readings range from 3.7 to 4.3 V when the brake pedal is released.

PMP_MTR**PMPSTAT**Range: _____ **ON/OFF**

Indicates the hydraulic pump motor operating status.

PUMP (V)Range: _____ **0 to 16 V**

Indicates the voltage signal being supplied to drive to the ABS pump.

R_WSPDRange: _____ **0 to vehicle max.**

Indicates the rear wheel speed sensor.

REGEN CO-OPRTRange: _____ **BEFORE, DURING**

Indicates the regenerate co-operation. Reads DURING while regenerate is operating.

REGEN COOPRange: _____ **ON/OFF**

Indicates the regenerative co-operation status. Reads ON when the system is operating, reads OFF at all other times.

REGEN TORQ FL (N-m)Range: _____ **0 to 4080 N*m**

Indicates the regenerative request torque (FL). 0 N*m indicates that ECB is not in operation.

REGEN TORQ FR (N-m)Range: _____ **0 to 4080 N*m**

Indicates the regenerative request torque (FR). 0 N*m indicates that ECB is not in operation.

REGEN TORQ RL (N-m)Range: _____ **0 to 4080 N*m**

Indicates the regenerative request torque (RL). 0 N*m indicates that ECB is not in operation.

REGEN TORQ RR (N-m)Range: _____ **0 to 4080 N*m**

Indicates the regenerative request torque (RR). 0 N*m indicates that ECB is not in operation.

RESERVOIR SWRange: _____ **ON/OFF**

Indicates the status of brake fluid reservoir level warning switch.

- ON when the reservoir level is normal
- OFF when the reservoir level is low

RF_WSPDRange: _____ **0 to vehicle max.**

Indicates the right front wheel speed sensor signal as vehicle speed.

RL ABS STATUSRange: _____ **ON/OFF**

Indicates the rear left wheel ABS control status. Reads ON when ABS is active, reads OFF at all other times.

RL PRS SEN (V)**RL W/C SENS (V)**Range: _____ **0.0 to 5.0 V**

Indicates the rear left pressure sensor signal. Typical readings range from 0.3 to 0.9 V when the brake pedal is released.

RL VSC STATUSRange: _____ **ON/OFF**

Indicates the rear left wheel VSC control status. Reads ON when VCS is active, reads OFF at all other times.

RL W/C SENRange: _____ **NORM, OPEN**

Indicates the rear left wheel cylinder pressure sensor open circuit detection. Reads NORM (normal) unless an open circuit is detected, reads OPEN when the circuit is open.

RL WHEEL ACCEL (m/s²)Range: _____ **-200.84 m/s² to 199.27 m/s²**

Indicates the rear left wheel rate of acceleration.

RL WHEEL SPDRange: _____ **0 mph to 202 mph or 0 km/h to 326 km/h**

Indicates the rear left wheel speed sensor reading. Actual wheel speed similar speed as indicated on the speedometer.

RR ABS STATUSRange: _____ **ON/OFF**

Indicates the rear right wheel ABS control status. Reads ON when ABS is active, reads OFF at all other times.

RR OPERATE TORQRange: _____ **0 N-m to 4,080 N-m**

Indicates the rear regenerative operation torque.

RR PRS SEN (V)**RR W/C SENS (V)**Range: _____ **0.0 to 5.0 V**

Indicates the rear right pressure sensor signal. Typical readings range from 0.3 to 0.9 V when the brake pedal is released.

RR RQST TORQRange: _____ **0 N-m to 4,080 N-m**

Indicates the rear regenerative request torque.

RR VSC STATUSRange: _____ **ON/OFF**

Indicates the rear right wheel VSC control status. Reads ON when VCS is active, reads OFF at all other times.

RR W/C SENRange: _____ **NORM, OPEN**

Indicates the rear right wheel cylinder pressure sensor open circuit detection. Reads NORM (normal) unless an open circuit is detected, reads OPEN when the circuit is open.

RR WHEEL ACCEL (m/s²)Range: _____ **-200.84 m/s² to 199.27 m/s²**

Indicates the rear right wheel rate of acceleration.

RR WHEEL SPDRange: _____ **0 mph to 202 mph or 0 km/h to 326 km/h**

Indicates the rear right wheel speed sensor reading. Actual wheel speed similar speed as indicated on the speedometer.

RR_WSPDRange: _____ **0 to vehicle max.**

Indicates the right rear wheel speed sensor.

SCSSRange: _____ **ON/OFF**

Indicates the stroke simulator solenoid (SCSS) status.

- ON when in operating mode
- OFF when in not operating mode

SIDE GRange: _____ **-24.3 to +24.1 m/s²**

Side G forces indicated by side G sensor. Approximately 0 m/s² when vehicle is stopped. When vehicle is moving, 24.3 to 24.1 m/s².

SLAFL CUR**SLAFL CURR (A)**Range: _____ **Min.: 0 A, Max.: 3 A**

Indicates the SLAFL solenoid current in amps. Should read 0 A when brake pedal is released.

SLAFR CUR**SLAFR CURR (A)**Range: _____ **Min.: 0 A, Max.: 3 A**

Indicates the SLAFR solenoid current in amps. Should read 0 A when brake pedal is released.

SLARL CUR**SLARL CURR (A)**Range: _____ **Min.: 0 A, Max.: 3 A**

Indicates the SLARL solenoid current in amps. Should read 0 A when brake pedal is released.

SLARR CUR**SLARR CURR (A)**Range: _____ **Min.: 0 A, Max.: 3 A**

Indicates the SLARR solenoid current in amps. Should read 0 A when brake pedal is released.

SLCT LVR POSI

Range: _____ P,R,N,D,1,2,3,4

Indicates shift position determined from the A/T PNP switch signal.

SLIP INDI LAMP

Range: _____ ON/OFF

Indicates the slip indicator light status. Reads ON when the indicator light is on, OFF when the indicator light is off.

SLIP LAMP

Range: _____ OFF/ON

Indicates SLIP lamp status. ON indicates TCS function is active, OFF indicates TCS function is inactive.

SLRFL CUR**SLRFL CURR (A)**

Range: _____ Min.: 0 A, Max.: 3 A

Indicates the SLRFL solenoid current in amps. Should read 0 A when brake pedal is released.

SLRFR CUR**SLRFR CURR (A)**

Range: _____ Min.: 0 A, Max.: 3 A

Indicates the SLRFR solenoid current in amps. Should read 0 A when brake pedal is released.

SLRRR CUR

Range: _____ Min.: 0 A, Max.: 3 A

Indicates the SLRRR solenoid current in amps. Should read 0 A when brake pedal is released.

SLRRL CUR

Range: _____ Min.: 0 A, Max.: 3 A

Indicates the SLRRL solenoid current in amps. Should read 0 A when brake pedal is released.

SMC1

Range: _____ ON/OFF

Indicates the master cut solenoid 1 (SMC1). Reads ON when the solenoid is energized, reads OFF at all other times.

SMC2

Range: _____ ON/OFF

Indicates the master cut solenoid 2 (SMC2). Reads ON when the solenoid is energized, reads OFF at all other times.

SNOW MODE SW

Range: _____ OFF/ON

Indicates the SNOW MODE switch status. Reads ON when switch is in snow mode operating position, reads OFF when switched off.

SPD SEN FR

Range: _____ NORM, OPEN

Indicates front right speed sensor open circuit detection. Reads NORM (normal) unless an open circuit is detected. An OPEN reading indicates an open circuit.

SPD SEN FLRange: _____ **NORM, OPEN**

Indicates front left speed sensor open detection. Reads NORM (normal) unless an open circuit is detected. An OPEN reading indicates an open circuit.

SPD SEN RRRange: _____ **NORM, OPEN**

Indicates rear right speed sensor open detection. Reads NORM (normal) unless an open circuit is detected. An OPEN reading indicates an open circuit.

SPD SEN RLRange: _____ **NORM, OPEN**

Indicates rear left speed sensor open detection. Reads NORM (normal) unless an open circuit is detected. An OPEN reading indicates an open circuit.

SSCRange: _____ **ON/OFF**

Indicates the SSC operating status. Reads ON when active, reads OFF at all other times.

STEERING ANG (°)**STEERING ANGLE (°)**Range: _____ **min: -1152 deg; max: 1150.875 deg**

Indicates the steering angle sensor output, in degrees. Left turn: Increase, Right Turn: Decrease.

STEERING SENRange: _____ **NORM, OPEN**

Indicates the steering sensor open detection. Reads NORM (normal) unless an open circuit is detected. An OPEN reading indicates an open circuit.

STOP LAMP SW**STOP LIGHT SW**Range: _____ **ON/OFF**

Indicates the stop light switch status. Reads ON when the brake pedal is depressed, OFF when the brake pedal is released.

STR ANGLERange: _____ **-720° to 720°**

Indicates steering angle detected by the steering angle sensor. Approximately 0° when straight ahead, -720 to 720° when vehicle is moving.

STROKE SEN 1Range: _____ **NORM, OPEN**

Indicates the stop light switch status. Reads NORM (normal) unless an open circuit is detected. An OPEN reading indicates an open circuit.

TCS OFF LAMPRange: _____ **OFF/ON**

Indicates TCS OFF lamp status. ON indicates TCS OFF lamp is on, OFF indicates TCS OFF lamp is off.

TCS OFF SWRange: _____ **OFF/ON**

Indicates TCS OFF switch status. ON indicates switch is pressed, OFF indicates switch is not pressed.

TEST MODERange: _____ **NORM/TEST**

Indicates the test mode status. Reads NORM (normal) unless test mode is active, reads TEST only during test mode operation.

TRAC STATUSRange: _____ **ON/OFF**

Indicates the TRAC control operating status. Reads ON when TRAC is active, reads OFF at all other times.

TRAC BRK STATUSRange: _____ **ON/OFF**

Indicates the TRAC brake control status.

V/R OUTPUTRange: _____ **OFF/ON**

Indicates status of actuator relay. ON indicates relay is active (KOER), OFF indicates relay is inactive (KOEO).

VDC OFF LAMPRange: _____ **OFF/ON**

Indicates VDC OFF lamp status. ON indicates VDC OFF lamp is on, OFF indicates VDC OFF lamp is off.

VDC OFF SWRange: _____ **OFF/ON**

Indicates VDC OFF switch status. ON indicates switch is pressed, OFF indicates switch is not pressed.

VEH SPEEDRange: _____ **0 to vehicle max.**

Indicates vehicle speed, the value is calculated by the ABS control module from the input voltage signals of the wheel speed sensors.

For ABS, this reading is not taken from the vehicle speed sensor (VSS) used by the PCM, and it may not be the same as the speedometer reading. An abnormally high, low, or erratic reading is usually due to wiring problems or faults in one or more wheel speed sensors.

VEHICLE SPDRange: _____ **0 mph to 202 mph or 0 km/h to 326 km/h**

Indicates the wheel speed sensor reading. Actual vehicle speed is indicated on the speedometer.

VLV_CTRRange: _____ **ON/OFF**

Indicates the ABS valve control relay.

VOLT M/C SENRange: _____ **-2.5 to 2.49 V**

Indicates the voltage signal of the master cylinder pressure sensor. Typical readings range from 0.3 to 0.9 V when the brake pedal is released.

VOLT M/C SENS 2Range: _____ **-2.5 to 2.49 V**

Indicates the voltage of the master cylinder pressure sensor 2.

VOLT STROK SEN (V)

Range: _____ -2.5 to 2.49 V

Indicates the voltage signal of the stroke sensor.

VOLT STROK SEN 2 (V)

Range: _____ -2.5 to 2.49 V

Indicates the voltage signal of stroke sensor 2.

VSC EQUIPED

Range: _____ NO/YES

Indicates the existence of VSC system. Reads YES if the test vehicle has a skid control system, reads no if the vehicle does not have skid control.

VSC/TRC OFF SW

Range: _____ ON/OFF

Indicates the status of the vehicle skid control or traction control switch. Reads ON when the switch is sent to the on position, reads OFF when the system is switched off.

VSC WARN LAMP

Range: _____ ON/OFF

Indicates the VSC warning lamp. Should read ON only when the lamp is illuminated, reads OFF at all other times.

WHEEL SPD FL**WHL SPD FL**

Range: _____ 0 mph to 202 mph or 0 km/h to 326 km/h

Indicates the wheel speed sensor (FL) reading, actual wheel speed. Similar speed as indicated on speedometer.

WHL SPD FR

Range: _____ 0 mph to 202 mph or 0 km/h to 326 km/h

Indicates the wheel speed sensor (FR) reading, actual wheel speed. Similar speed as indicated on speedometer.

WHEEL SPD RL**WHL SPD RL**

Range: _____ 0 mph to 202 mph or 0 km/h to 326 km/h

Indicates the wheel speed sensor (RL) reading, actual wheel speed. Similar speed as indicated on speedometer.

WHEEL SPD RR**WHL SPD RR**

Range: _____ 0 mph to 202 mph or 0 km/h to 326 km/h

Indicates the wheel speed sensor (RR) reading, actual wheel speed. Similar speed as indicated on speedometer.

YAW RATE

Range: _____ -70 to 70 d/s

Indicates yaw rate detected by yaw rate sensor. 0 d/s when vehicle is stopped, -70 to 70 d/s when vehicle is moving.

YAW RATE

Range: _____ min: -128 deg/s; max: 128 deg/s

Indicates the yaw rate sensor output, in degrees per second.

YAW RATE SENRange: _____ **NORM,OPEN**

Indicates the yaw rate sensor open detection, NORMAL: Normal condition.

YAW RATE SENS 1Range: _____ **min: -128 deg/s; max: 127 deg/s**

Indicates the yaw rate sensor 1, in degrees per second.

YAW RATE SENS 2Range: _____ **min: -128 deg/s; max: 127 deg/s**

Indicates the yaw rate sensor 2, in degrees per second.

YAW RATE VALUERange: _____ **min: -128 deg/s; max: 127 deg/s**

Indicates the yaw rate value, in degrees per second.

YAW ZERO VALUERange: _____ **min: -128 deg/s; max: 128 deg/s**

Indicates the memorized zero value output, in degrees per second.

ZERO DECELERAT (m/s²)Range: _____ **min: -25.11 m/s² to max: 24.91 m/s²**

Indicates the memorized zero value.

ZERO STEERINGRange: _____ **min: -3276.8 deg/s; max: 3276.7 deg/s**

Indicates the memorized zero value, in degrees per second.

ZERO YAW RATE**ZERO YAW RATE 2**Range: _____ **min: -128 deg/s; max: 127 deg/s**

Indicates the memorized zero value, in degrees per second.

Airbag (SRS) Parameters

This section defines parameters available from the airbag or supplemental restraint system (SRS) systems. To find the description of a specific parameter, locate the parameter name in the index and then go to the listed page.

BRACKET(Ohms)

Range: _____ 0 to 22.5 Ω

Indicates the resistance of the airbag mounting ground.

CRSHSN1

Range: _____ 0 to 22.5 Ω

Indicates the resistance of the crash sensor.

D_Airbag(Ohms)

Range: _____ 0 to 22.5 Ω

Indicates the driver's airbag resistance.

D_AirBAG2(Ohms)

Range: _____ 0 to 22.5 Ω

Indicates the driver's side airbag resistance.

D_ABAGR(Ohms)

Range: _____ 0 to 22.5 Ω

Indicates the driver's airbag resistance to ground.

D_PReTNR(Ohms)

Range: _____ 0 to 22.5 Ω

Indicates the driver's seat belt pretensioner resistance.

DAB

PAB

Range: _____ FIRE/NO FIRE

Indicates the deployment status of the driver airbag (DAB) and the passenger airbag (PAB). It normally reads NO FIRE; a FIRE reading means the airbag was deployed.

DEPLOYMENTS

Range: _____ 0/1

Indicates a count of the number of times the airbags have been deployed.

DR_PTENS(Ohms)

Range: _____ 0 to 22.5 Ω

Indicates the driver's seat belt retractor (pretensioner) resistance.

DRV IMPACT ID

Range: _____ 01 to 99

Indicates the driver SIS ID, a 2-digit number. This information is sent to the SDM when the ignition first turns on.

DRVR BELT

PASS BELT

Range: _____ BUCKLED/UNBUCKLED

Indicates the status of the driver (DRVR) and passenger (PASS) seat belts.

DS_AB(Ohms)
Range: _____ 0 to 22.5 Ω

Indicates the driver's airbag resistance.

DSBELTR(Ohms)
Range: _____ 0 to 22.5 Ω

Indicates the driver's seat belt retractor (pretensioner) circuit resistance.

DTC_CNT
Range: _____ not available

Indicates the number of trouble codes set.

EXTXRSH
Range: _____ 0.0 to 17.0 V

Indicates the external crash sensor test voltage.

IGN_(V)
Range: _____ 0.0 to 17.0 V

Indicates the RCM ignition voltage.

LAMP
SRS LAMP
Range: _____ ON/OFF

Indicates the PCM command status to the Airbag or SRS lamp on the instrument panel.

OCS
Range: _____ actual

Indicates the occupant classification system.

OPS_ST
Range: _____ actual

Indicates the front passage occupant classification system.

P_ABAGR(Ohms)
Range: _____ 0.0 to 22.5 Ω

Indicates the passenger side airbag module resistance.

P_ABAGR2(Ohms)
Range: _____ 0.0 to 22.5 Ω

Indicates the passenger side airbag #2 resistance.

P_Airbag(Ohms)
Range: _____ 0.0 to 22.5 Ω

Indicates the passenger side airbag module resistance.

P_AirBAG2(Ohms)
Range: _____ 0.0 to 22.5 Ω

Indicates the passenger's side airbag resistance.

P_PReTNR(Ohms)
Range: _____ 0.0 to 22.5 Ω

Indicates the passenger retractor (pretensioner) circuit resistance.

PABAGR(Ohms)
Range: _____ 0.0 to 22.5 Ω

Indicates the passenger side airbag module resistance.

PASS IMPACT ID

Range: _____ 10 to 99

Indicates a two digit ID number and typically reads 43.

PBSW_C(A)

Range: _____ actual

Indicates the passenger buckle switch current measurement.

PS_AB(Ohms)Range: _____ 0.0 to 22.5 Ω

Indicates the passenger side impact air bag resistance.

PS_BUKL

Range: _____ IN/OUT

Indicates the passenger buckle switch status.

PS_PTENS(Ohms)Range: _____ 0.0 to 22.5 Ω

Indicates the passenger's seat belt retractor (pretensioner) resistance.

PSBELTR(Ohms)Range: _____ 0.0 to 22.5 Ω

Indicates the passenger's seat belt pretensioner resistance.

SEAT_TRAC**TRAK_SW**

Range: _____ FORWARD/REVERSE

Indicates the seat track position.

TIME ON (HOURS)

Range: _____ 0 to 21.25 hours

Indicates the length of time in hours since the PCM set the first airbag DTC.

VBATT (V)

Range: _____ 0.0 to 25.0 V

Indicates the voltage being supplied to the airbag electronic control module (ECM).

Air Conditioning (A/C) Parameters

This section defines data parameters that are available from the A/C electronic control module (A/C ECM), which controls the adjustment of the climate in the passenger compartment of the vehicle. This section applies only to models with a stand alone A/C ECM. Parameters for A/C systems incorporated into the body control module (BCM) are defined in the BCM section.

Air Inlet Damper Pulse

Range: _____ 0 to 255

Displays the pulse of the signal provided to the air inlet damper.

Air Inlet Mode

Range: _____ AUTO/MANUAL

Indicates the setting of the mode switch for the system air intake.

Air Mix Pulse-D

Air Mix Pulse-P

Range: _____ 0 to 255

Shows the signal pulse supplied to the driver (-D) and passenger (-P) side air mixture doors.

Air Out Pulse-D

Air Out Pulse-P

Range: _____ 0 to 255

Shows the signal pulse supplied to the driver (-D) and passenger (-P) side air outlet doors.

Ambi Temp

Range: _____ -30.8 to 50.8°C or -23 to 123°F

Indicates the A/C ECM adjusted ambient air temperature.

Ambi Temp Sensor

Range: _____ -23.3 to 65.95°C or -10 to 150°F

Indicates the ambient temperature as determined by the sensor (not adjusted).

Ambient Temp Shift

Range: _____ see below

Indicates the ambient temperature shift. Possible readings are: INV (invalid), -3°C, -2°C, -1°C, NORMAL, +1°C, +2°C, +3°C.

Auto Blow Up

Range: _____ NO/OFF

Indicates the status of the Foot/Defrost automatic blow up function.

Blower Level

Range: _____ 0 to 31

Indicates the level of the blower motor speed.

Button Prs Buzz

Range: _____ ON/OFF

Indicates the on/off status of the button press buzzer.

Compressor Mode

Range: _____ AUTO/MANUAL

Indicates the operating status of the compressor.

Comprs/Def Oper
Range: _____ LINK/NORMAL

Indicates the compressor and defroster operation mode.

Coolant Temp
Range: _____ -1.3 to 90.55°C or 34 to 195°F

Indicates the engine coolant temperature.

Emiss Gas Sens
Range: _____ 0 to 255

Indicates the status of the emissions gas sensor, reading should increase as the amount of gas emissions increases.

Evap Ctrl
Range: _____ AUTO/MANUAL

Indicates the status of the evaporator control.

Evap Temp
Range: _____ -29.7 to 59.55°C or -21 to 139°F

Indicates the temperature of the evaporator as determined by an evaporator sensor.

Foot Air Leak
Range: _____ ON/OFF

Indicates the status of a foot air leak.

Foot/Def Auto Mode
Range: _____ ON/OFF

Indicates the on/off status of the foot defrost automatic mode.

Hand Free Tel
Range: _____ ON/OFF

Indicates the on/off status of the hands free telephone operating mode.

NOX Gas Sens
Range: _____ 0 to 255

Indicates the status of the NOX gas sensor, reading should increase as the amount of NOX emissions increases.

Reg Ctrl Curr(A)
Range: _____ 2 to 255A

Indicates the regulator control current as amps.

Reg Press Sens
Range: _____ -0.45668 to 3.29437 MPaG

Indicates regulator pressure as determined by the regulator pressure sensor.

Room Temperature
Range: _____ -6.5 to 57.25°C or -20 to 135°F

Indicates the temperature of the passenger compartment air as determined by the room temperature sensor.

Set Temp-D
Set Temp-P
Range: _____ not available

Shows the selected temperature setting for the driver (-D) and passenger (-P) side.

Shift Temp**Range:** _____ **see below**

Indicates the temperature set shift. Possible readings are: INV (invalid), -2°C, -1°C, NORMAL, +1°C, +2°C.

Solar Sens-D**Solar Sens-P****Range:** _____ **0 to 255**

Shows the solar sensor setting for the driver (-D) and passenger (-P) side.

Body Control Module (BCM) Parameters

This section defines the data parameters available from the body control module (BCM) on vehicles equipped with a BCM that have the ability to communicate with a scan tool. It also includes the Ford Generic Electronic Module (GEM) parameters used on some Mazda models. To find the description of a specific parameter, locate the parameter name in the index and then go to the listed page.



NOTE:

Because of the personalized selection of optional equipment and trim packages available, some BCM parameters displayed may not be supported by the vehicle as identified. Some BCM parameters may appear inactive or invalid.

A thorough understanding of vehicle specific BCM operation will prevent lost time or an inaccurate diagnosis based on incorrect interpretation of data for the vehicle being tested.

For example: An inactive FRONT DOOR LOCK RELAY parameter is noticed by a technician diagnosing an intermittent power-door lock problem while sitting in the driver seat and pushing the door lock button. However, the REAR DOOR LOCK RELAY parameter switches as expected. By thinking that this indicates a fault, a lot of time could be wasted looking for an open in the FRONT DOOR LOCK RELAY circuit or replacing a BCM.

In fact, this would be normal operation if the vehicle has a driver door module with an incorporated power-door lock switch. The FRONT DOOR LOCK RELAY parameter is a device the BCM can command, but this may not be the primary method used to command its operation.

The switch activates the FRONT DOOR LOCK RELAY direct without BCM interaction, therefore the parameter does not change. At the same time, the door module sends a lock request input signal to the BCM to command activation of the REAR DOOR LOCK RELAY, therefore the rear parameters change. The BCM commanded the operation of the REAR DOOR LOCK RELAY, but does not need to command the FRONT DOOR LOCK RELAY. In order to see the FRONT DOOR LOCK RELAY parameter change state, a remote keyless entry or key fob lock signal is needed to request the BCM to command the FRONT and/or REAR DOOR LOCK RELAY to lock one or all the doors.

A vehicle that is not equipped with a remote keyless entry option may switch the parameters in a different manner.

Codes

Range: _____ **0 to 255**

Displays the number of diagnostic trouble codes (DTCs) in memory.

1TOUCH_DN

Range: _____ **ON/OFF**

Indicates the one touch down switch status.

ACC Sw

Range: _____ **ON/OFF**

Indicates the status of the ignition switch. Reads ON when the switch is in the accessory position, reads OFF at all other times.

Acc On Sw

Range: _____ **ON/OFF**

Indicates whether the ignition switch is in the accessory (ACC) position. Reads ON with the switch in ACC position and OFF at all other times.

ACC Relay Mon
Range: _____ **ON/OFF**

Indicates the status of the ignition accessory relay monitor. Reads ON when the ignition switch is in the accessory position, reads OFF when the switch is off.

ACSW
Range: _____ **ON/OFF**

Indicates the air conditioning switch status.

AFS Off Sw
Range: _____ **ON/OFF**

Indicates the status of the AFS off switch. reads ON when the switch is on and OFF when off.

Alarm Function
Range: _____ **ON/OFF**

Indicates the status of the panic function of the alarm system. Reads ON when panic is active, reads OFF when panic is disabled.

Air Cond Sw
Range: _____ **ON/OFF**

Indicates the status of the Air conditioner switch, reads ON when switched on and OFF when off.

All Unlock/Opn-Cls
Range: _____ **ON/OFF**

Indicates the setting of the all unlock system. Reads ON when the system is active, all doors unlock when the driver door is opened. Reads OFF when the system is disabled.

Alt L-Term Sig
Range: _____ **ON/OFF**

Indicates the signal status of alternator terminal L. Should read OFF when the starter is cranking, reads ON at all other times.

Armed State Indicator
Range: _____ **ON/OFF**

Displays the on/off status of the alarm system. Reads ON when armed and off when disabled.

AT_HORN
Range: _____ **ON/OFF**

Indicates the anti-theft horn status.

Auto Light Sw
Headlamp Auto Signal
Light Auto Sw
Range: _____ **ON/OFF**

Indicates the position of the lighting control switch. Reads ON when the switch is set to the "auto" position and reads OFF at all other times.

AUTO LIGHT SW
Range: _____ **OFF**

This Nissan parameter displays, but cannot be monitored.

AUTOLMP
Range: _____ **ON/OFF**

Indicates the autolamp switch status.

Auto Lock Delay

Range: _____ 30/60

Displays the delay setting of the automatic door lock system in seconds.

Auto Lock/Shift

Range: _____ ON/OFF

Indicates the status of the automatic lock shift system. Reads ON when the system is active, all doors lock when the gear selector lever is shifted from park into any other position.

Auto Unlock/Shift

Range: _____ ON/OFF

Indicates the status of the automatic unlock shift system. Reads ON when the system is active, all doors unlock when the gear selector lever is shifted into park from any other position.

Auto Wiper

Range: _____ ON/OFF

Indicates the status of the automatic windshield wiper system. Reads ON when the system is active and reads OFF when the system is disabled.

B_AJAR

Range: _____ OPEN/CLSD

Indicates the hood switch ajar status.

Back Door Open Sw**BACK DOOR SW**

Range: _____ ON/OFF

Indicates the status of the power back door switch. Reads ON when the switch is depressed to open the back door, reads OFF at all other times.

BACKUPLMP**Backup Light Sw**

Range: _____ ON/OFF

Indicates the back-up lamp switch status. Reads ON when the gear selector lever is in reverse position, reads OFF at all other times.

Back-Up Light Transistor

Range: _____ ON/OFF

Indicates the status of the back-up lamp transistor. Reads ON when the transistor is on (gear selector lever is in "R" position), and off at all other times.

BACK DIM DUTY CYCLE (%)

Range: _____ 0 to 100%

Indicates the duty cycle of the pulse width modulated (PWM) signal distributed by the BCM to the PWM controlled instrument panel (IP) backlighting. The reading is based on the position of the IP dimmer switch (rheostat). The display reads 0% when the head lamp switch is in the Auto position and the daytime running lamps (DRL) are on, or when the IP dimmer switch is in the Full Dim position. The display reads about 85% when the low beam head lamps or park lamps are on and the IP dimmer switch is in the Full Bright position.

Back Door Open Sw

Range: _____ ON/OFF

Indicates the status of the back door courtesy lamp switch. Reads ON when the back door is open, reads OFF when the door is closed.

BATT (V)
 Range: _____ **0.0 to 16.0 V**

Indicates vehicle battery voltage, the value is the system voltage measured at the BCM ignition feed input.

The reading should be close to normal charging system regulated voltage with the engine running. This is typically 13.5 to 14.5 V at idle. Check the reading against actual voltage measured at the battery or alternator. Check vehicle specifications for exact values.

BATT_SAVR
 Range: _____ **ON/OFF**

Indicates the battery saver relay control.

BRK_FLUID
 Range: _____ **OK/LOW**

Indicates the brake fluid level.

C_LOCK_SW
 Range: _____ **ON/OFF**

Indicates the central lock switch.

C_UNLOCK_SW
 Range: _____ **ON/OFF**

Indicates the central unlock switch.

Com B-Door P/W
 Range: _____ **OK/STOP**

Indicates the connection status between the back door power window ECM and the main BCM. Reads ok when there is a connection, reads stop when unable to communicate. A malfunction sets a DTC.

Com ACC G/Way
 Range: _____ **OK/STOP**

Indicates the connection status between the accessory gateway ECM and the main BCM. Reads OK when there is an active connection between the modules, reads STOP when the modules are unable to communicate. A malfunction sets a DTC.

Com Body No. 4
Com Body No. 5
 Range: _____ **OK/STOP**

Indicates the connection status between the indicated ECM and the main BCM. Reads OK when there is an active connection between the modules, reads STOP when the modules are unable to communicate. A malfunction sets a DTC.

Com CTR Console
Communication CTR Console
 Range: _____ **WITH/WITHOUT**

Indicates current communication between the number 1 console switch and the main BCM. Reads WITH when there is a connection, reads WITHOUT when unable to communicate. A malfunction sets a DTC.

Com CRLAC
Communication RL Seat A/C
Com CRRAC
Communication RR Seat A/C

Range: _____ **WITH/WITHOUT**

Indicates current communication between the indicated (CRLAC and RL = left rear, CRRAC and RR = right rear) seat climate control ECM the and the main BCM. Reads WITH when there is a connection, reads WITHOUT when unable to communicate. A malfunction sets a DTC.

Com CRLS
Com CRRS

Range: _____ **WITH/WITHOUT**

Indicates current communication between the indicated (CRLS = left, CRRS = right) rear seat position control ECM the and the main BCM. Reads WITH when there is a connection, reads WITHOUT when unable to communicate. A malfunction sets a DTC.

Com Cruise Ctrl

Range: _____ **OK/STOP**

Indicates the connection status between the cruise control ECM and the main BCM. Reads OK when there is an active connection between the modules, reads STOP when the modules are unable to communicate. A malfunction sets a DTC.

Com Combi Sw

Range: _____ **OK/STOP**

Indicates the connection status between the combination switch ECM and the main BCM. Reads OK when there is an active connection between the modules, reads STOP when the modules are unable to communicate. A malfunction sets a DTC.

Com D-Door
Com P-Door
Com RR-Door
Com RL-Door

Range: _____ **OK/STOP**

Indicates the connection status between the indicated (D = driver, P = passenger, RR = rear right, RL = rear left) door ECM and the main BCM. Reads OK when there is an active connection between the modules, reads STOP when the modules are unable to communicate. A malfunction sets a DTC.

Com D-Door/Mirr

Range: _____ **OK/STOP**

Indicates the connection status between the driver side mirror ECM and the main BCM. Reads OK when there is an active connection between the modules, reads STOP when the modules are unable to communicate. A malfunction sets a DTC.

Com D-Door Mtr
Com P-Door Mtr
Com RR-Door Mtr
Com RL-Door Mtr

Range: _____ **OK/STOP**

Indicates the connection status between the indicated (D = driver, P = passenger, RR = rear right, RL = rear left) power window regulator ECM and the main BCM. Reads OK when there is an active connection between the modules, reads STOP when the modules are unable to communicate. A malfunction sets a DTC.

Com D-Seat**Range:** _____ **OK/STOP**

Indicates the connection status between the driver side seat ECM and the main BCM. Reads OK when there is an active connection between the modules, reads STOP when the modules are unable to communicate. A malfunction sets a DTC.

Com D-Seat Sw**Range:** _____ **OK/STOP**

Indicates the connection status between the driver side seat switch ECM and the main BCM. Reads OK when there is an active connection between the modules, reads STOP when the modules are unable to communicate. A malfunction sets a DTC.

Com Double Lock**Range:** _____ **OK/STOP**

Indicates the connection status between the double lock ECM and the main BCM. Reads OK when there is an active connection between the modules, reads STOP when the modules are unable to communicate. A malfunction sets a DTC.

Com Entry & Start**Range:** _____ **OK/STOP**

Indicates the connection status between the entry and start ECM and the main BCM. Reads OK when there is an active connection between the modules, reads STOP when the modules are unable to communicate. A malfunction sets a DTC.

Com FL Seat A/C**Communication FL Seat A/C****Com FR Seat A/C****Communication FR Seat A/C****Range:** _____ **WITH/WITHOUT**

Indicates current communication between the indicated (FL = left, FR = right) front seat climate control ECM the and the main BCM. Reads WITH when there is a connection, reads WITHOUT when unable to communicate. A malfunction sets a DTC.

Com Master Sw**Range:** _____ **OK/STOP**

Indicates the connection status between the power window master switch ECM and the main BCM. Reads OK when there is an active connection between the modules, reads STOP when the modules are unable to communicate. A malfunction sets a DTC.

Com Mayday**Range:** _____ **OK/STOP**

Indicates the connection status between the ECMs and the main BCM. Reads OK when there is an active connection between the modules, reads STOP when the modules are unable to communicate. A malfunction sets a DTC.

Com Mayday G/Way**Range:** _____ **OK/STOP**

Indicates the connection status between the Mayday Gateway and the main BCM. Reads OK when there is an active connection between the modules, reads STOP when the modules are unable to communicate. A malfunction sets a DTC.

Com Meter**Range:** _____ **OK/STOP**

Indicates the connection status between the meter ECM and the main BCM. Reads OK when there is an active connection between the modules, reads STOP when the modules are unable to communicate. A malfunction sets a DTC.

Com Park Assist**Range:** _____ **OK/STOP**

Indicates the connection status between the park assist ECM and the main BCM. Reads OK when there is an active connection between the modules, reads STOP when the modules are unable to communicate. A malfunction sets a DTC.

Com P-Seat**Range:** _____ **OK/STOP**

Indicates the connection status between the passenger seat ECM and the main BCM. Reads OK when there is an active connection between the modules, reads STOP when the modules are unable to communicate. A malfunction sets a DTC.

Com Pwr B-Door**Range:** _____ **OK/STOP**

Indicates the connection status between the power back door ECM and the main BCM. Reads OK when there is an active connection between the modules, reads STOP when the modules are unable to communicate. A malfunction sets a DTC.

Com R-Console**Range:** _____ **OK/STOP**

Indicates the connection status between the rear console ECM and the main BCM. Reads OK when there is an active connection between the modules, reads STOP when the modules are unable to communicate. A malfunction sets a DTC.

Com Slide Roof**Range:** _____ **OK/STOP**

Indicates the connection status between the sunroof ECM and the main BCM. Reads OK when there is an active connection between the modules, reads STOP when the modules are unable to communicate. A malfunction sets a DTC.

Com S/W Pad Sw**Range:** _____ **OK/STOP**

Indicates the connection status between the steering wheel paddle switches and the main BCM. Reads OK when there is an active connection between the modules, reads STOP when the modules are unable to communicate. A malfunction sets a DTC.

Com TDS**Range:** _____ **OK/STOP**

Indicates the connection status between the theft deterrent system (TDS) ECM and the main BCM. Reads OK when there is an active connection between the modules, reads STOP when the modules are unable to communicate. A malfunction sets a DTC.

Com Tilt & Tele**Range:** _____ **OK/STOP**

Indicates the connection status between the steering column tilt and telescope ECM and the main BCM. Reads OK when there is an active connection between the modules, reads STOP when the modules are unable to communicate. A malfunction sets a DTC.

Com Tire PressureRange: _____ **OK/STOP**

Indicates the connection status between the tire pressure ECM and the main BCM. Reads OK when there is an active connection between the modules, reads STOP when the modules are unable to communicate. A malfunction sets a DTC.

Car FinderRange: _____ **ON/OFF**

Displays the status of the car finder of the wireless remote. Reads ON when the car finder feature is active, and reads OFF when it is disabled. When active, the car horn sounds when the remote button is pressed.

CCNT_TPMSRange: _____ **actual**

Indicates the number of continuous codes.

COURTESY LAMP SW**Courtesy Sw**Range: _____ **ON/OFF**

Indicates the position of the courtesy lamp switch. The reading should be ON when the switch is turned on and OFF at all other times. The BCM uses this data in controlling the courtesy lamp operation.

Curr Com RainRange: _____ **OK/STOP**

Indicates current communication between the rain sensor ECM and the main BCM. Reads OK when there is an active connection between the modules, reads STOP when the modules are unable to communicate. A malfunction sets a DTC.

D Door Cty Sw**Hood Courtesy Sw****P Door Cty Sw****Rear Door Courtesy Sw****RL Door Courtesy Sw****RR Door Courtesy Sw**Range: _____ **ON/OFF**

Indicates the status of the indicated door courtesy lamp switch. D is driver, Hood is engine compartment, P is passenger, Rear is hatch, RL is rear left and RR is rear right. Reads ON when the switch is on (door open) and off at all other times.

D Mirror Memory M1**D Mirror Memory M2****P-Mirror Memory M1****P-Mirror Memory M2**Range: _____ **MEM/NOT MEM**

Indicates whether or not a mirror position is saved in memory. D is driver side, P is passenger side, M1 is memory 1, and M2 is memory 2. Reads MEM when a position is saved and NOT MEM when there is no position saved in memory.

D Seat Buckle Sw**P Seat Buckle Sw****SEAT BELT SW**Range: _____ **ON/OFF**

Indicates the status of the seat belt (D is driver, P is passenger) switches. Reads ON when the seat belt buckle is latched and reads OFF when the buckle is disconnected.

D_UP_SWRange: _____ **UP/DOWN**

Indicates the status of the driver door up switch.

DD_LOCKRange: _____ **ON/OFF**

Indicates the status of the driver door lock switch.

DD_UNLOCKRange: _____ **ON/OFF**

Indicates the status of the driver door unlock switch.

Dimmer Sw**Dimmer HI Sw**Range: _____ **ON/OFF**

Indicates the position of the headlight dimmer switch. Reads ON when the switch is positioned to operate the high beam headlamps, reads OFF at all other times.

DIMMING INPUT (V)Range: _____ **0.0 to 5.0 V**

Indicates the position of the IP dimmer switch (rheostat). The display reads 4.0 V when the head lamp switch is in the Auto position and the day time running lamps (DRL) are on, or the IP dimmer switch is in the Full Dim position. The display reads 0 V when the park lamps or the head lamps are on and the IP dimmer switch is in the Full Bright position.

DIMMING LEVEL (%)Range: _____ **0 to 100%**

Indicates the duty cycle of the signal distributed by the BCM to the pulse width modulated (PWM) door switch backlighting based on the position of the IP dimmer switch (rheostat). It reads 0% when the head lamp switch is in the Auto position and the daytime running lamps (DRL) are on, or the IP dimmer switch is in the Full Dim position. It reads 100% when the head lamps or park lamps are on and the IP dimmer switch is in the Full Bright position.

Display Ext ON SensRange: _____ **-2/-1/NORM/+1/+2**

Displays the extinction luminous intensity.

Display Ext OFF SensRange: _____ **-2/-1/NORM/+1/+2**

Displays the extinction release luminous intensity.

DLIDLKSWRange: _____ **ON/OFF**

Indicates the trunk/liftgate lock relay status.

DLIDULSWRange: _____ **ON/OFF**

Indicates the trunk/liftgate unlock relay status.

DOMELM_SW
 Range: _____ **ON/OFF**

Indicates the dome light switch status.

Door Key Linked Lock Sw

Key Sw (Lock)

Key Sw-Lock

Range: _____ **ON/OFF**

Indicates if the driver door is being locked with a key. Reads ON if the door is being locked with a key, reads OFF at all other times.

Door Key Linked Unlock Sw

Key Sw (Unlock)

Key Sw-Unlock

D Door Key Sw-UNLOCK

P Door Key Sw-UNLOCK

Range: _____ **ON/OFF**

Indicates if a door lock is being activated with a key. D Door is the driver door, P Door is the passenger door, all others apply to any door. Reads ON if the door is being unlocked with a key, reads OFF at all other times.

Door Lock (Lock)

Driver Lock Position Sw

Range: _____ **ON/OFF**

Indicates the manual door lock switch signal for the passenger door. Reads ON if the door is unlocked, reads OFF at all other times.

Door Lock (Unlock)

Pass Door Lock Sw

Range: _____ **ON/OFF**

Indicates the manual door lock switch signal for the driver door. Reads ON if the door is locked, reads OFF at all other times.

Door Lock Sw

Range: _____ **ON/OFF**

Indicates the status of the electric lock/unlock switch. Reads ON when the switch is pressed to lock the doors, and reads OFF at all other times.

Door Lock Sw-LOCK

Range: _____ **ON/OFF**

Displays the door lock switch signal. Reads ON if the door is locked, reads OFF when unlocked.

Door Lock Sw-UNLOCK

Range: _____ **ON/OFF**

Displays the door lock switch signal. Reads ON if the door is unlocked, reads OFF when locked.

Door Lock Sw Status

Range: _____ **ON/OFF**

Indicates the manual door lock control switch signal. Reads ON if the door is locked with the switch, reads OFF at all other times.

Door Unlock Sw Status**Pass Door Unlock Sw**Range: _____ **ON/OFF**

Indicates the manual door lock control switch signal. Door is the main switch and Pass is the passenger door. Reads ON if the door is unlocked with the switch, reads OFF at all other times.

DOOR SW AS**DOOR SW DR**Range: _____ **ON/OFF**

Indicates the door switch signal status for the driver (DR) and passenger (AS) doors.

Door Sw LF**Door Sw LR****Door Sw RF****Door Sw RR**Range: _____ **ON/OFF**

indicates the status of the door switch for the left front (LF), left rear (LR), right front (RF), and right rear (RR) doors. Reads ON when the indicated door is open, and OFF when closed.

DOOR SW-RRRange: _____ **Not Available**

Indicates the door switch signal status for the rear door. This Nissan parameter displays even on models without a rear door with remote release.

Door Unlock SwRange: _____ **ON/OFF**

Indicates the status of the electric lock/unlock switch. Reads ON when the switch is pressed to unlock the doors, and reads OFF at all other times.

Down/Door Key**Up/Door Key**Range: _____ **ON/OFF**

Displays the power window settings. Read on if the system is active, reads OFF when disabled. When active, all of the power windows go down or up if the driver door key is held in the lock position for 1.5 seconds.

DRIVER/LR DOOR AJAR SW**D Door Warning Sw****PASS/RR DOOR AJAR SW**Range: _____ **ON/OFF**

Indicates the state of the applicable door, reads OFF when the door is fully closed, and reads ON when the door is open or ajar.

Driver PSD Sw**Pass PSD Sw**Range: _____ **ON/OFF**

Indicates the status of the driver and passenger power slide door main switches. Reads ON when the switch is activated to open the door, reads OFF at all other times.

DRLK_RLYRange: _____ **ON/OFF**

Indicates the all doors lock relay.

DRL_L
 Range: _____ ON/OFF

Indicates the daytime running lamp, left.

DRL_R
 Range: _____ ON/OFF

Indicates the daytime running lamp, right.

DRL Function
 Range: _____ ON/OFF

Indicates the status of the daytime running lamp (DRL) system. Reads ON when DRL system is activated, reads OFF when the system is off.

DRUNLK_RLY
 Range: _____ ON/OFF

Indicates the all doors unlock relay.

Drv P/W Auto Sw
Pass P/W Auto Sw
RL P/W Auto Sw
RR P/W Auto Sw
 Range: _____ ON/OFF

Indicates the status of the indicated automatic power window switches. Drv is the driver switch, Pass is the passenger switch, RL is the rear left switch, RR is the rear right switch. Reads ON when the switch is activated and off at all other times.

Drv P/W Up Sw
Pass P/W UP Sw
RL P/W Up Sw
RR P/W Up Sw
 Range: _____ ON/OFF

Indicates the status of the indicated power window up switches. Drv is the driver switch, Pass is the passenger switch, RL is the rear left switch, RR is the rear right switch. Reads ON when the switch is activated and off at all other times.

Drv P/W Down Sw
Pass P/W Down Sw
RL P/W Down Sw
RR P/W Down Sw
 Range: _____ ON/OFF

Indicates the status of the indicated power window down switches. Drv is the driver switch, Pass is the passenger switch, RL is the rear left switch, RR is the rear right switch. Reads ON when the switch is activated and off at all other times.

Drvr Door Lock Posit Sw
Lock Posit Sw
Pass Lock Posit Sw
Rear Lock Posit Sw
RL Lock Posit Sw
 Range: _____ ON/OFF

Indicates the door unlock detection switch signal. Drvr is the driver switch, Lock is the master switch, Pass is the passenger switch, Rear is the hatch switch, RL is the rear left switch. Reads ON when the switch is on (unlocked) and off when the switch is off (locked).

ECT Power Mode SwRange: _____ **ON/OFF**

Displays the on/off status of the electronically controlled transmission power mode switch. Reads ON when the switch is active and reads OFF at all other times. When active, the shift pattern is optimized for performance.

ECT Snow Mode SwRange: _____ **ON/OFF**

Displays the on/off status of the electronically controlled transmission snow mode switch. Reads ON when the switch is active and reads OFF at all other times. When active, the shift pattern is optimized for traction and the vehicle starts out in second gear.

E/G ConditionRange: _____ **RUN/STOP**

Displays the operating status of the engine. Reads RUN when the engine is running, and reads STOP when the engine is off.

Engine RunningRange: _____ **ON/OFF**

Indicates whether or not the engine is running. Reads ON when the engine is running.

Engine StatusRange: _____ **STOP/STALL/RUN/CRANK**

Indicates the operating status of the engine.

Entry DelayRange: _____ **0/14/30**

Displays the setting of the delay time of the wireless entry system in seconds.

F Fog Light Sw**FOG_F_SW****Front Fog Light Sw****FRONT FOG LAMP SW**Range: _____ **ON/OFF**

Indicates the position of the front fog lamp switch. Reads ON only when the front fog lamp switch is activated with the park lamps or low beam head lamps turned on.

Front Fog SwRange: _____ **ON/OFF**

Indicates the position of the front fog lamp switch, reads ON when the switch is on.

Front Washer SwitchRange: _____ **ON/OFF**

Indicates the status of the windshield washer switch, reads ON when the switch is on.

Front Wiper HighRange: _____ **ON/OFF**

Indicates the position of the front wiper switch. Reads ON only when the switch is in the high speed position.

Front Wiper IntRange: _____ **ON/OFF**

Indicates the position of the front wiper switch. Reads ON only when the switch is in the intermittent position.

Front Wiper Int VolumeRange: _____ **ON/OFF**

Indicates the position of the front wiper switch. Reads ON only when intermittent volume is selected on the switch.

Front Wiper LowRange: _____ **ON/OFF**

Indicates the position of the front wiper switch. Reads ON only when the switch is in the low speed position.

Front Wiper StopRange: _____ **ON/OFF**

Indicates the position of the front wiper switch. Reads ON only when the switch is in the off position and the wipers are parked.

FLASH TO PASS SW**High Flasher Sw****Passing Light Sw****PASSING SW**Range: _____ **ON/OFF**

Indicates the position of the flash to pass or passing light switch. Reads ON only when the switch is held to momentarily activate the high beams, reads OFF when the switch is released.

FOGRLY_FRange: _____ **ON/OFF**

Indicates the front fog lamp relay.

Foot LightsRange: _____ **ON/OFF**

Displays the on/off setting for the foot lights.

FR FOG SWRange: _____ **OFF**

This Nissan parameter displays, but cannot be monitored.

FR WASHER SW**WASH_SW**Range: _____ **ON/OFF**

Indicates the status of the windshield washer switch.

FR WIPER HI**FR WIPER INT****FR WIPER LOW****FR WIPER STOP**Range: _____ **ON/OFF**

Indicates the position of the windshield wiper switch. Reads ON when the switch is in the indicated (high speed, intermittent, low speed, or off) position.

FRONT WIPERS ACTIVERange: _____ **YES/NO**

Indicates the state of the wiper motor. Reads YES when the wipers are operating (after about 3 cycles of the wiper blades), reads NO at all other times.

FRWPPRKSRange: _____ **WIPE/PARK**

Indicates the front windshield wiper status.

Fuel Lid Open SwRange: _____ **ON/OFF**

Indicates the status of the fuel lid opener (remote) switch. Reads ON when the switch is pressed to open the fuel lid, reads OFF at all other times.

H-Level Warning SigRange: _____ **ON/OFF**

Indicates the status of the headlamp level warning system, reads ON when the warning lamp is activated, reads OFF at all other times.

HAZARD**Hazard Sw**Range: _____ **ON/OFF**

Indicates the hazard switch status, reads ON when the switch is on and OFF at all other times.

Hazard Answer BackRange: _____ **ON/OFF**

Indicates the status of the wireless hazard answer-back system. Reads ON when the system is active, reads OFF when the system is disabled.

HBEAMSWRange: _____ **ON/OFF**

Indicates the high beam switch status.

HEADLAMP**HEAD LAMP SW**Range: _____ **ON/OFF**

Indicates the status of the headlamp switch signal circuit.

Head Lamp Sw 1Range: _____ **ON/OFF**

Indicates the status of head lamp switch 1 (low beams), reads ON when the switch is on.

Head Lamp SW 2**HEAD LAMP SW 2**Range: _____ **ON/OFF**

Indicates the status of the headlamp switch 2, reads ON when the switch is on.

Headlamp Signal**Head Light Sw**Range: _____ **ON/OFF**

Indicates the position of the light control switch. Reads ON when the switch is set to the "head" position and reads OFF at all other times.

HEADLAMP WASHERRange: _____ **ON/OFF**

Indicates the position of the headlamp washer switch. Reads ON when the switch is activated and OFF at all other times.

**HI BEAM SW
HIGH BEAM SELECT**Range: _____ **ON/OFF**

Indicates the position of the high beam switch. Reads ON when the switch is in the position that activates the high beams.

High Beam SWRange: _____ **ON/OFF**

Indicates the status of the high beam light switch, reads ON when the switch is on.

**Hood Sw
HOOD SW**Range: _____ **ON/OFF**

Indicates the status of the engine compartment hood switch. Reads ON if the hood is open and OFF when closed.

HOOD OPEN SWRange: _____ **ON/OFF**

Indicates the status of the hood ajar switch signal circuit. An open switch (door open) is displayed as ON.

High Mount STOP Light transistorRange: _____ **ON/OFF**

Indicates the status of the high mounted stop lamp transistor. Reads ON when the transistor is on (brake pedal depressed), and off at all other times (brake pedal released).

Hist Com RainRange: _____ **OK/STOP**

Indicates history communication between the rain sensor ECM and the main BCM. Reads OK when there is an active connection between the modules, reads STOP when the modules are unable to communicate. A malfunction sets a DTC.

Horn SwRange: _____ **ON/OFF**

Indicates the status of the horn switch. Reads ON when the horn switch is on (horn sounding) and off at all other times.

HORN_TPMRange: _____ **ACTIVE/INACTIVE**

Indicates the horn output.

I-Key HatchRange: _____ **ON/OFF**

Indicates the status of the hatch button on the Intelligent Key remote transmitter. Reads ON only when the hatch button is pressed and reads OFF at all other times.

I-Key LockRange: _____ **ON/OFF**

Indicates the status of the lock button on the Intelligent Key remote transmitter. Reads ON only when the lock button is pressed and reads OFF at all other times.

I-Key TrunkRange: _____ **ON/OFF**

Indicates the status of the trunk button on the Intelligent Key remote transmitter. Reads ON only when the trunk button is pressed and reads OFF at all other times.

I-Key PanicRange: _____ **ON/OFF**

Indicates the status of the panic button on the Intelligent Key remote transmitter. Reads ON only when the panic button is pressed and reads OFF at all other times.

I-Key Pwr Window DownRange: _____ **ON/OFF**

Indicates the status of the power window down feature of the Intelligent Key system. Reads ON when the unlock button of the remote transmitter is pressed and held to lower the windows.

I-Key UnlockRange: _____ **ON/OFF**

Indicates the status of the unlock button on the Intelligent Key remote transmitter. Reads ON only when the unlock button is pressed and reads OFF at all other times.

IGKEY_ILLURange: _____ **ON/OFF**

Indicates illuminated entry.

Ign On Sw**IGN ON SW**Range: _____ **ON/OFF**

Indicates the status of the ignition switch. Reads ON when the switch is in the ON position and reads off at all other times

IGNITION 0Range: _____ **ON/OFF**

Indicates the ignition 0 position. Input to the control module from the ignition switch indicating the ignition 0 position. Reads ON when ignition 1 switch circuit is closed, reads OFF at all other times. Positions are:

- UNLOCK
- ACC
- ON (Run)
- START

IGNITION 1Range: _____ **ON/OFF**

Indicates the input to the control module from the ignition switch indicating the ignition 1 position. Reads ON when ignition 1 switch circuit is closed, reads OFF at all other times.

Ignition 1 switch closed positions are:

- ON (Run)
- START

IG1 Relay Mon1**IG1 Relay Mon2****IG2 Relay Mon1****IG2 Relay Mon2**Range: _____ **ON/OFF**

Indicates the status of the ignition relay monitors:

- IG1 Mon1 = ignition 1 inner relay
- IG1 Mon2 = ignition 1 outer relay

- IG2 Mon1 = ignition 1 inner relay
- IG2 Mon2 = ignition 1 outer relay

All should read on when the ignition switch is on, and off when the switch is off.

IGNITION 3

Range: _____ ON/OFF

Indicates the input to the control module from the ignition switch indicating the ignition 3 position. Reads ON when the switch is closed in the ON (Run) position only, reads OFF at all other times.

IGNITION ACCESSORY

Range: _____ ACTIVE/INACTIVE

Indicates the input to the control module from the ignition switch accessory circuit. Reads ACTIVE when ignition accessory switch circuit is closed (in accessory and run positions), reads INACTIVE at all other times.

IG Sw Signal

MPX-IG Sw

Range: _____ ON/OFF

Indicates the status if the ignition switch. Reads OFF when the switch is in the off position, reads ON at all other times.

I/L On/ACC Off

Range: _____ ON/OFF

Indicates the status if the interior lighting with ACC off. When on, the interior lights illuminate when ACC off is in the on position. When off, the interior lights illuminate when ACC off is in the off position.

I/Light On/Unlock

Range: _____ ON/OFF

Indicates the status if the interior lighting with unlock. When on, the interior lights illuminate when unlock is on. When off, the interior lights illuminate when unlock is off.

Illumination Sw

Interior Light

Range: _____ ON/OFF

Indicates the status of the interior lighting switch. Reads ON when the switch is pushed in, reads OFF when the switch is not pushed in.

The Illumination SW parameter is for the switch marked ON/OFF and the Interior Light parameter is for the switch marked DOOR.

Illumination System

Light Control

Range: _____ ON/OFF

Indicates the status of the lighting control system. Reads ON when the system is on, reads OFF when the system is off.

INT VOLUME

Range: _____ 1/2/3/4/5/6/7

Indicates the interval setting for the windshield wipers.

INADVERTENT POWER RELAY

Range: _____ ON/OFF

Indicates the state of the inadvertent power battery rundown protection feature of the BCM. Reads OFF when all inadvertent power circuits are functioning normally.

INDICATOR DIMMINGRange: _____ **0 to 100%**

Indicates the duty cycle of the pulse width modulated (PWM) signal distributed by the BCM to the PWM controlled IP backlighting based on the position of the IP switch. The display reads 1.2% when the headlamp switch is in the Auto position and the daytime running lamps (DRL) are on, or the IP dimmer switch is in the Full Dim position. The display reads 100% when the head lamps or park lamps, are turned on and the IP dimmer switch is in the Full Bright position.

INTERIOR LAMP DEFEATRange: _____ **ON/OFF**

Indicates the position of the courtesy/dome lamp override switch. Reads ON only when the switch is activated, which indicates a BCM to override the normal interior lamp activation inputs and deactivate the interior lighting.

Interior Light ON UnlockRange: _____ **ON/OFF**

Displays the remote wireless entry system setting for the interior lamps. Reads ON and the interior lights illuminate when the doors are unlocked with the remote. When OFF, the interior lights do not illuminate when the doors are unlocked.

Key Cyl Lock Sw**KEY CYL LK-SW**Range: _____ **ON/OFF**

Indicates the status of the door key switch, reads ON when locking the doors with a key.

Key Cyl Unlock Sw**KEY CYL UN-SW**Range: _____ **ON/OFF**

Indicates the status of the door key switch, reads ON when unlocking the doors with a key.

KEY IN IGNITIONRange: _____ **YES/NO****Key Insert On Sw****Key Unlock Warn Sw**Range: _____ **ON/OFF**

Indicates whether the ignition key is inserted into the ignition switch. Reads YES or ON with key in the ignition switch, NO or OFF when there is no key in the ignition switch.

KEY ON SWRange: _____ **ON/OFF**

Indicates the status of the key switch.

Keyless Keep Lock**Keyless Keep Unlock**Range: _____ **ON/OFF**

Indicates the status of the keep lock/unlock feature of the keyless entry system. Reads ON only when both the lock unlock buttons on the remote transmitter are pressed and held.

Keyless LockRange: _____ **ON/OFF**

Indicates the status of the lock button on the keyless entry remote transmitter. Reads ON only when the lock button is pressed and reads OFF at all other times.

Keyless PanicRange: _____ **ON/OFF**

Indicates the status of the panic button on the keyless entry remote transmitter. Reads ON only when the panic button is pressed and reads OFF at all other times.

Keyless Pwr Sliding Left Door**Keyless Pwr Sliding Right Door**Range: _____ **ON/OFF**

Indicates the status of the power sliding door feature of the keyless entry system. Reads ON when the PSD (power sliding door) button of the remote transmitter is pressed to open or close the indicated door.

Keyless Pwr Rear HatchRange: _____ **ON/OFF**

Indicates the status of the hatch button on the keyless entry remote transmitter. Reads ON only when the hatch button is pressed and reads OFF at all other times.

Keyless Pwr Rear TrunkRange: _____ **ON/OFF**

Indicates the status of the trunk button on the keyless entry remote transmitter. Reads ON only when the trunk button is pressed and reads OFF at all other times.

Keyless UnlockRange: _____ **ON/OFF**

Indicates the status of the unlock button on the keyless entry remote transmitter. Reads ON only when the unlock button is pressed and reads OFF at all other times.

LAST_IDRange: _____ **actual**

Indicates the last received tire transmitter ID code value.

Latch CircuitRange: _____ **ON/OFF**

Displays the latch circuit status. Reads ON with the ignition switch on or the engine running, reads OFF with the ignition switch off or in accessory position.

LBEAM_AUTORange: _____ **ON/OFF**

Indicates the auto low beam out relay.

LEFT FRONT SOLAR SNSR (V)**LIGHT SENSOR (V)****R FRONT SOLAR SENSOR (V)**Range: _____ **0.0 to 5.0 V**

Indicates the output voltage of the applicable ambient light sensor based on the intensity of light detected. As the light intensity increases, the sensor voltage decreases. In the Light state, a low voltage of more than 1.75 volts is present and the DRL will be on. In the Dark state, a high voltage of up to 4.9 volts is present and the head lamps will be on.

Left Turn SwRange: _____ **ON/OFF**

Indicates the status of the turn signal switch, reads ON when the switch is in the left turn position.

LF_PW (A)
 Range: _____ actual

Indicates the left front power window amperage draw.

LF_AJAR
 Range: _____ OPEN/CLSD

Indicates the left front door ajar status.

LF_ID
 Range: _____ actual

Indicates the left front tire transmitter identifier.

LF_LRN
 Range: _____ ACTIVE/INACTIVE

Indicates the left front learn status.

LF_MES
 Range: _____ ACTIVE/INACTIVE

Indicates the left front measure status.

LF_NORM
 Range: _____ ACTIVE/INACTIVE

Indicates the left front normal status.

LF_PSI
 Range: _____ actual

Indicates the left front tire pressure.

LF_REC
 Range: _____ YES/NO

Indicates the left front transmit received after learn.

LFAWAKE
 Range: _____ YES/NO

Indicates the left front awake status.

LFDR_SW
 Range: _____ CLSD/AJAR

Indicates the left front door switch.

LFIDPRG
 Range: _____ YES/NO

Indicates the left front sensor programmed.

LFLOBAT
 Range: _____ LOW/OK

Indicates the left front low battery.

LFPW_PEAK (A)
 Range: _____ actual

Indicates the left front power window peak amp draw.

LFPW_SW
 Range: _____ OFF, DOWN, UP, ONE TOUCH

Indicates the left front power window switch.

LHTURN_IND**Turn Left Sw**Range: _____ **ON/OFF**

Indicates the status of the turn indicator switch. Reads ON when the switch is positioned to operate the left-hand indicators, reads OFF at all other times.

Lighting TimeRange: _____ **7.5/15/30**

Displays the setting of the lighting time seconds.

Light Off DelayRange: _____ **30/60/90**

Displays the setting of the automatic lighting delay in seconds. Lights remain on for the displayed time after the ignition is switched off.

Lin Com**Lin Communication**Range: _____ **WITH/WITHOUT**

Indicates current communication between the LIN ECM the and the main BCM. Reads WITH when there is a communication connection, reads WITHOUT when unable to communicate. A malfunction sets a DTC.

LK BUTTON/SIGRange: _____ **ON/OFF**

Indicates a door lock switch signal being received from a remote transmitter.

LOCK SW AS**LOCK SW DR**Range: _____ **ON/OFF**

Indicates the door lock switch signal status for the driver (DR) and passenger (AS) doors.

Lock/IG On DrvRange: _____ **ON/OFF**

Displays the status of the lock command system. Reads ON when active and off when disabled. When active, all doors automatically lock when the gear selector lever is moved to drive position while the ignition is switched on.

LOW BEAM DUTY CYCLE (%)Range: _____ **0 to 100%**

Indicates the duty cycle of the pulse width modulated (PWM) ground signal controlling the headlamp driver module (HDM). The BCM uses this feature to signal the HDM to operate the low beam head lamps in low beam headlamp mode at full intensity (100%) or in DRL mode at a reduced intensity (81%).

LR_AJARRange: _____ **OPEN/CLSD**

Indicates the left rear door ajar status.

LR_IDRange: _____ **actual**

Indicates the left rear tire transmitter identifier.

LR_LRNRange: _____ **ACTIVE/INACTIVE**

Indicates the left rear learn status.

LR_MES
Range: _____ ACTIVE/INACTIVE

Indicates the left rear measure status.

LR_NORM
Range: _____ ACTIVE/INACTIVE

Indicates the left rear normal status.

LR_REC
Range: _____ YES/NO

Indicates the left rear transmit received after learn.

LRAWAKE
Range: _____ YES/NO

Indicates the left rear awake status.

LRIDPRG
Range: _____ YES/NO

Indicates the left rear sensor programmed.

LRLOBAT
Range: _____ LOW/OK

Indicates the left rear low battery.

LRO_PSI
Range: _____ actual

Indicates the left rear outer tire pressure.

Lugg Courtesy Sw
Range: _____ ON/OFF

Indicates the position of the luggage courtesy lamp switch. Reads ON when the luggage compartment courtesy lamp switch is turned on and OFF at all other times.

Mirror Fold Sw (Retractable Mirror)
Range: _____ ON/OFF

Indicates the status of the retractable mirror switch. Reads ON when the switch is set to retract the mirror, reads OFF at all other times.

Mirror Pos Sw (Right)

Mirror Pos Sw (Left)

Mirror Pos Sw (Up)

Mirror Pos Sw (Down)

Range: _____ ON/OFF

Indicates whether or not the power mirror position switch is in the indicated position (right, left, up, or down). Reads ON when the switch is in the indicated position, OFF at all other times.

Mirror Return Sw (Retractable Mirror)
Range: _____ ON/OFF

Indicates the status of the retractable mirror switch. Reads ON when the switch is set to extend the mirror, reads OFF at all other times.

Mirror Sel Sw (Right)**Mirror Sel Sw (Left)**Range: _____ **ON/OFF**

Indicates the position of the power mirror select switch. Reads ON when the switch is in the indicated (right or left) position, off at all other times.

N SwRange: _____ **ON/OFF**

Indicates whether or not the gear selector lever is in neutral range. Reads ON when in neutral range, reads OFF in all other ranges.

N Sw/C Sw**P/N Pos Sw****P/N Position Sw**Range: _____ **ON/OFF**

Indicates the status of the park/neutral position (PNP) switch, or neutral start switch. Reads ON when the gear selector lever is in the park or neutral range, reads OFF in all other ranges.

Oil Press SwRange: _____ **ON/OFF**

Indicates the state of the oil pressure warning lamp on the instrument cluster. Reads ON when the lamp is lit, and reads OFF at all other times.

Optical Sensor (V)Range: _____ **0.00 to 5.00 V**

Indicates the optical sensor signal voltage, which varies with the amount of ambient light. Reads 0.00 V in darkness and 4.50 to 5.00 in full light.

Open Door WarningRange: _____ **ON/OFF**

Indicates the status of the open door warning system. Reads ON when the system is active (a door is open) and reads OFF at all other times.

P/W Lock SwRange: _____ **ON/OFF**

Indicates the status of the power window lock switch. Reads ON when the lock feature is active, and reads OFF when released.

PARK_LAMPRange: _____ **ON/OFF**

Indicates the parking lamps status.

PARK_SWRange: _____ **ON/OFF**

Indicates the park light switch status.

PARK BRAKE SWITCHRange: _____ **RELEASE/SET****Park Brake Sw****Parking Brake Sw****PKBS Sw**Range: _____ **ON/OFF**

Indicates the position of the parking brake. Reads SET or ON when the switch is closed (park brake is engaged). Reads RELEASE or OFF when the parking brake is released.

The BCM uses this data in controlling the parking brake indicator, the reminder chime feature and the DRL system.

PARK LAMP SWITCH

Range: _____ ON/OFF

Indicates the park lamp switch signal circuit status. A closed switch is displayed as ON.

Passing Sw

Range: _____ ON/OFF

Indicates the status of the lamp switch, reads ON when Passing position is selected.

Passive Mode

Range: _____ ON/OFF

Displays the passive mode status. Reads ON if passive mode on, and OFF if passive mode off.

PD_LOCK

Range: _____ ON/OFF

Indicates the power door lock status.

PD_UNLOCK

Range: _____ ON/OFF

Indicates the power door unlock status.

PWR Condition

Range: _____ ALL/ACC ON/IG1 ON/IG2 ON/ST ON

Displays the status of various system relays:

- ALL—all relays are off.
- ACC ON—the accessory relay is energized
- IGN1 ON—the ignition 1 relay is energized
- IGN2 ON—the ignition 2 relay is energized
- ST ON—the start request relay is energized

PRK_BRK

Range: _____ ON/OFF

Indicates the parking brake status.

PRK_BRAKE

Range: _____ ON/OFF

Indicates the parking brake switch status.

Push Sw

Range: _____ ON/OFF

Indicates the status of the push button ignition switch. Reads ON when the button is depressed.

PWM_ILLU

Range: _____ ON/OFF

Indicates the illuminated pulse width modulated (PWM) value.

R Shade Close

Range: _____ YES/NO

Indicates the status of the read sun shade limit switch. Reads YES if the switch is off (shade lowered), and NO if the switch is on (shade raised).

R Shade Delay Time

Range: _____ OFF/0.7S/0.9S/1.2S

Indicates the status of the read sun shade delay setting. Reads OFF when the system is disabled, other readings are the programmed delay in seconds.

RDEF_RLY

Range: _____ ON/OFF

Indicates the rear defrost relay status.

Rear Def Sw**RDEF_SW**

Range: _____ ON/OFF

Indicates the rear defogger switch status, reads ON when the switch is on and OFF when off.

REAR FOG LAMP SW**R Fog Light Sw**

Range: _____ ON/OFF

Indicates the position of the rear fog lamp switch. Reads ON when the front fog lamp switch is activated with the park lamps or low beam head lamps turned on, and OFF at all other times.

Rear Hatch Sw

Range: _____ ON/OFF

Indicates the status of the rear hatch, reads ON when the hatch is open and OFF when closed.

Rear Shade Sw

Range: _____ ON/OFF

Indicates the status of the rear sun shade switch. Reads ON when the switch is pressed, and reads OFF at all other times.

Rear Washer Sw**RR WASHER SW**

Range: _____ ON/OFF

Indicates the status of the rear window washer switch. Reads ON when the switch is on.

Rear Wiper Int**Rear Wiper On****Rear Wiper Stop****RR WIPER INT****RR WIPER ON****RR WIPER STOP**

Range: _____ ON/OFF

Indicates the position of the rear window wiper switch. Reads ON when the switch is in the indicated position (Int = intermittent, on = on, stop = off) .

REMOTE_ID

Range: _____ actual

Indicates the remote identification.

REMOTES

Range: _____ actual

Indicates the number of programmed transmitters.

RESET_SW

Range: _____ ON/OFF

Indicates the driver door key cylinder switch status.

Response Time
Range: _____ 0.1/1.0

Displays the response time setting in seconds.

Rewipe Function
Range: _____ ON/OFF

Indicates the status of the automatic windshield rewipe system. Reads ON when rewipe is available, and reads OFF when not available.

Rewipe Time
Range: _____ 3/4

Displays the interval timing for the automatic windshield wiper system in seconds.

RF_AJAR
Range: _____ OPEN/CLSD

Indicates the right front door ajar status.

RF_ID
Range: _____ actual

Indicates the right front tire transmitter identifier.

RF_LRN
Range: _____ ACTIVE/INACTIVE

Indicates the right front learn status.

RF_MES
Range: _____ ACTIVE/INACTIVE

Indicates the right front measure status.

RF_NORM
Range: _____ ACTIVE/INACTIVE

Indicates the right front normal status.

RF_PSI
Range: _____ actual

Indicates the right front tire pressure status.

RF_REC
Range: _____ YES/NO

Indicates the right front transmit received after learn.

RFAWAKE
Range: _____ YES/NO

Indicates the right front awake status.

RFDR_SW
Range: _____ CLSD/AJAR

Indicates the right front door status.

RFIDPRG
Range: _____ YES/NO

Indicates the right front sensor programmed.

RFLOWBAT
Range: _____ LOW/OK

Indicates the right front low battery status.

RHTURN_IND**Turn Right Sw**Range: _____ **ON/OFF**

Indicates the status of the turn indicator switch. Reads ON when the switch is positioned to operate the right-hand indicators, reads OFF at all other times.

Right Turn SwRange: _____ **ON/OFF**

Indicates the turn signal switch status, reads ON when the switch is in the right turn position.

RR_AJARRange: _____ **OPEN/CLSD**

Indicates the right rear door ajar status.

RR_IDRange: _____ **actual**

Indicates the right rear tire transmitter identifier.

RR_LRNRange: _____ **ACTIVE/INACTIVE**

Indicates the right rear learn status.

RR_MESRange: _____ **ACTIVE/INACTIVE**

Indicates the right rear measure status.

RR_NORMRange: _____ **ACTIVE/INACTIVE**

Indicates the right rear normal status.

RRIDPRGRange: _____ **YES/NO**

Indicates the right rear sensor programmed status.

RRLOBATRange: _____ **LOW/OK**

Indicates the right rear low battery status.

RRO_RECRange: _____ **YES/NO**

Indicates the right rear transmit received after learn status.

RRO_PSIRange: _____ **actual**

Indicates the right rear outer tire pressure status.

P/W Func/KeyRange: _____ **ON/OFF**

Displays the setting for the driver door key window switches. Reads ON when the driver key window feature is active, and reads OFF when it is disabled.

P/W Func/RemoteRange: _____ **ON/OFF**

Displays the setting for the wireless transmitter window switches. Reads ON when the remote window feature is active, and reads OFF when it is disabled.

P/W Down/Wireless**P/W Up/Wireless**Range: _____ **ON/OFF**

Indicates the status of the wireless transmitter window switches. Reads ON when the windows are commanded up or down with the remote, reads OFF at all other times.

Seat Belt IndicatorRange: _____ **ON/OFF**

Indicates the status of the seat belt indicator lamp. Reads ON if the lamp is on (belt unlatched), and OFF if the lamp is off (belt latched).

Seat Mem 1 Sw**Seat Mem 2 Sw**Range: _____ **ON/OFF**

Indicates the status of the indicated seat memory switches. Reads ON when the indicated switch is activated, reads OFF at all other times.

Seat Mem Set SwRange: _____ **ON/OFF**

Indicates the status of the indicated seat memory set switch. reads ON when the seat memory switch is activated, reads OFF at all other times.

SensitivityRange: _____ **-40%/ -20%/ NORM/ +20%/ +40%**

Displays the sensitivity setting.

Shift position NRange: _____ **ON/OFF**

Indicates whether or not the transmission is in neutral range, reads ON when in neutral and OFF at all other times.

Shift position PRange: _____ **ON/OFF**

Indicates whether or not the transmission is in park range, reads ON when in park and OFF at all other times.

Shift position RRange: _____ **ON/OFF**

Indicates whether or not the transmission is in reverse range, reads ON when in reverse and OFF at all other times.

Sport A/T SwRange: _____ **ON/OFF**

Displays the on/off status of the electronically controlled transmission sport mode switch. Reads ON when the switch is active and reads OFF at all other times. When active, the shift pattern is altered to delay upshifts and quicken throttle downshifts.

Speed ModeRange: _____ **ON/OFF**

Displays the speed mode status. Reads ON when speed mode is available, and OFF when speed mode is not available.

SPR_IDRange: _____ **actual**

Indicates the spare tire transmitter identifier.

STEERING WHEEL CONTROL(V)

Range: _____ 0.0 to 5.0 V

Indicates if voltage is supplied to the steering wheel controls.

STEERING WHEEL SW PWR

Range: _____ 0.0 to 5.0 V

Indicates the voltage of the steering wheel controls power supply.

Stop Light Sw

Range: _____ ON/OFF

Indicates the status of the stop lamp switch. Reads ON when the brake pedal is depressed (brake lamps illuminated), reads OFF when the brake pedal is released.

Stop Light Transistor

Range: _____ ON/OFF

Indicates the status of the stop lamp transistor. Reads ON when the transistor is on (brake pedal depressed), and OFF at all other times (brake pedal released).

Str Unlock Sw

Range: _____ ON/OFF

Displays the status of the steering wheel lock. Reads ON when the steering is unlocked and OFF when the ignition is switched off and the steering lock is engaged.

STSW1**STSW2**

Range: _____ ON/OFF

Displays the status of start switch 1 and start switch 2. Reads ON when the indicated switch is depressed and reads OFF at all other times.

Tail Cancel Sw

Range: _____ ON/OFF

Indicates the state of the tail cancel switch of the light control rheostat. Reads ON when the tail cancel switch is on and reads OFF at all other times.

Tail Light Sig

Range: _____ ON/OFF

Indicates the state of the tail light signal. Reads ON when the tail lamps are on and reads OFF at all other times.

Tail Lamp**Tail Light Sw**

Range: _____ ON/OFF

Indicates the position of the light control switch. Reads ON when the switch is set to the "tail" or "head" position and reads OFF at all other times.

Tail Light Transistor

Range: _____ ON/OFF

Indicates the status of the tail lamp transistor. Reads ON when the lighting control switch is in the "tail" or "head" position, and OFF at all other times.

TAIL_AJAR

Range: _____ OPEN/CLSD

Indicates the liftgate ajar switch status.

TNSMT_CMD
Range: _____ **actual**

Indicates the last remote control transmission.

TNSMTR_ID
Range: _____ **actual**

Indicates the last received transmitter ID code reference.

TRUNK_AJAR
Range: _____ **OPEN/CLSD**

Indicates the trunk switch status.

Trunk Opener Sw
Trunk/Back Door Open Sw
Range: _____ **ON/OFF**

Indicates the status of the trunk or rear gate opener switch. Reads ON when the switch is activated to open the trunk or gate.

TRUNK BTN/SIG
Range: _____ **ON/OFF**

Indicates the status of the trunk, or back door, unlock switch signal from a remote transmitter.

Trunk Cyl Sw
TRUNK KEY SW
Range: _____ **ON/OFF**

Displays the trunk key switch status. Reads ON when the trunk is being unlocked.

Trunk Key Unlock
Range: _____ **ON/OFF**

Indicates the trunk lock status. Reads ON if the trunk is locked, reads OFF when unlocked.

Trunk Lid Operation
Range: _____ **1 TIME/2 TIMES/0.8S**

Displays the setting of the wireless trunk opener switch. Interpret as follows:

- 1 TIME—trunk opens when the button is pressed once.
- 2 TIMES—trunk opens when the button is pressed twice.
- 0.8S—trunk opens when the button is pressed and held for 0.8 second.

Trunk Main Sw
Range: _____ **ON/OFF**

Indicates the status of the trunk opener cancel switch. Reads ON when the cancel switch is on, and reads OFF at all other times.

Trunk Opener Monitor
TRUNK OPN MNTR
Range: _____ **ON/OFF**

Displays the trunk, or back door open monitor. Reads ON when open and OFF when closed.

TRUNK OPNR SW
Range: _____ **Not Available**

Displays the trunk opener switch status. This Nissan parameter displays even on models without a rear door with remote release.

UN BUTTON ON
UN BUTTON/SIG
 Range: _____ **ON/OFF**

Indicates a door unlock switch signal being received from a remote transmitter.

UNLK SW AS
UNLK SW DR
 Range: _____ **ON/OFF**

Indicates the door unlock switch signal status for the driver (DR) and passenger (AS) doors.

Unlock2 Operation
 Range: _____ **ON/OFF**

Indicates the status of the 2 times wireless unlock system. Reads ON when the system is active and all doors unlock when the button is pressed twice. Reads OFF when the system is disabled.

Unlock w/KOEO & Park
 Range: _____ **ON/OFF**

Indicates the status of the KOEO and park door unlock system. Reads ON when the system is active, all doors unlock when the ignition is off and the gear selector lever is shifted into Park.

Vehicle Speed
VSS_TPM
 Range: _____ **0 to MAX SPEED**

Indicates the vehicle speed.

Vehicle Spd Sig
 Range: _____ **STOP/RUN**

VHCL SPEED SEN
 Range: _____ **ON/OFF**

Indicates whether or not the vehicle is in motion, reads STOP or OFF when the vehicle is at rest and RUN or ON while running or moving.

WARN_1
 Range: _____ **actual**

Indicates the TPMS last warning event #1 –Transmitter ID.

WARN_2
 Range: _____ **actual**

Indicates the TPMS last warning event #2 –Transmitter ID.

WARN_3
 Range: _____ **actual**

Indicates the TPMS last warning event #3 –Transmitter ID.

WARN_4
 Range: _____ **actual**

Indicates the TPMS last warning event #4 –Transmitter ID.

WARN_5
 Range: _____ **actual**

Indicates the TPMS last warning event #5 –Transmitter ID.

Warn By Glass Snsr
 Range: _____ **ON/OFF**

Indicates the status of the glass breakage sensor of the alarm system. Reads ON when the sensor detects breaking glass, reads OFF at all other times.

Warn By HornRange: _____ **ON/OFF**

Indicates the status of the warning by horn system. Reads ON when the system is active and the horn sounds when the alarm is triggered, reads OFF when the horn alarm is disabled.

WASH_FRTRange: _____ **ON/OFF**

Indicates the front washer switch status.

WASHPUMPRange: _____ **ON/OFF**

Indicates the washer pump status.

WASHRLYRange: _____ **ON/OFF**

Indicates the washer relay status.

WIP SwRange: _____ **ON/OFF**

Indicates the availability of power to the windshield wiper switch. Reading should be ON whenever the ignition is switched on, and OFF when the ignition is off.

WIP Sw (+1)**WIP Sw (C1)****WIP Sw (2S)****WIP Sw (SM)**Range: _____ **ON/OFF**

Indicates the availability of power at the indicated terminal of the windshield wiper switch. Reads ON when power is available at the terminal, and OFF when power is not available.

Wireless Buzzer ResponseRange: _____ **ON/OFF**

Indicates the status of the wireless door lock buzzer response system. Reads ON when the system is active and reads OFF when the system is disabled.

Wireless Door Lock OperationRange: _____ **ON/OFF**

Indicates the status of the wireless entry system. Reads ON when the system is active and the doors can be unlocked without a key, reads OFF when the system is disabled.

WPINT_FRTRange: _____ **ON/OFF**

Indicates the front wiper interval/auto wiper switch status.

WPFASST_FRTRange: _____ **ON/OFF**

Indicates the front wiper relay, fast speed status.

WPRLY_LOWRange: _____ **ON/OFF**

Indicates the front wiper relay, low speed status.

WPRLY_REARRange: _____ **ON/OFF**

Indicates the rear wiper relay status.

WPINT_REAR

Range: _____ **ON/OFF**

Indicates the rear wiper interval position switch status.

WPRPRKSTS

Range: _____ **ON/OFF**

Indicates wiper in park position status.

Engine Parameters

This section defines engine data parameters available from the engine control module (ECM), powertrain control module (PCM) or the vehicle control module (VCM). To find the description of a specific parameter, locate the parameter name in the index and then go to the listed page.

+BM

Range: _____ ON/OFF

Indicates whether or not electric throttle control system has input power. ON: Idling.

+BM VOLTS

Range: _____ Min.: 0, Max.: 19.922 V

Indicates +BM voltage: 10 to 15 V: Idling.

#CARB CODES

Range: _____ Min.: 0, Max.: 255

Indicates the number of emission related DTCs.

#CODES

Range: _____ Min.: 0, Max.: 255

Indicates number of detected DTCs.

1ST GEAR

2ND GEAR

3RD GEAR

4TH GEAR

Range: _____ actual

Indicates the gear commanded by the module.

2nd AIR MON ENA

Range: _____ UNABLE/ENABLE

Indicates the secondary AIR monitor.

2nd AIR MON CMPL

Range: _____ COMPLETE/INCOMPLETE

Indicates the secondary AIR monitor.

2ND SELECTED

Range: _____ YES/NO

Indicates the gear selected.

40 CYCLES

Range: _____ CMPLT/INCMP

Indicates whether a DTC has remained active for 40 drive cycles.

4WD ENGAGED

Range: _____ ON/OFF

Indicates the 4WD switch status.

4WD LOW SW

Range: _____ ON/OFF

Indicates the position of the four-wheel drive low switch. Reads ON when the switch is on.

5V REF (V)Range: _____ **0.0 to 5.12 V**

Indicates the reference voltage that the system sensors operate on. The nominal reference value is 5.0 V, but voltage may vary slightly depending on system calibration and charging voltage.

A/C CLUTCHRange: _____ **ON/OFF**

Indicates the status of the A/C compressor clutch, it reads ON when the clutch is engaged.

A/C CLUTCH RELAY**A/C RELAY**Range: _____ **ON/OFF**

Indicates a feedback signal from the A/C compressor clutch or relay, it reads:

- ON when the clutch is engaged
- OFF when the clutch is disengaged

Some vehicles provide both the A/C REQUEST and the A/C CLUTCH parameters. They should cycle together (both ON or both OFF) unless the ECM is overriding the instrument panel control. Others models have an A/C REQUEST parameter but do not monitor A/C CLUTCH feedback.

A/C COMP SWRange: _____ **LO/NORM**

Indicates the state of the A/C compressor cycling switch. Readings should be:

- LO when pressure is low
- NORM when pressure is normal.

The A/C compressor cycling switch is normally closed.

A/C CUT**A/C CUT SIG****A/C SIG**Range: _____ **ON/OFF**

Indicates the status of the A/C cut signal from the PCM to the A/C control assembly. Reads ON only when the PCM is actively disabling the A/C compressor in order to prevent overloading the engine during a heavy load operation.

A/C ENABLEDRange: _____ **ON/OFF**

Indicates the status of the air conditioning switch.

A/C HI-SIDE (psi)**A/C PRESS (psi)****A/C PRESS (kPa)**Range: _____ **25 to 460 psi or 170 to 3170 kPa**

Indicates the PCM calculated refrigerant pressure based on the voltage signal from the A/C high-side pressure sensor. The value reflects the load that the A/C compressor is placing on the engine. Typically, readings are slightly low when pressure is decreasing and slightly high when pressure is increasing. The value is used to adjust idle and control the cooling fans.

A/C IDLE UP VSVRange: _____ **ON/OFF**

Indicates the ECM command to the A/C idle-up vacuum switching valve (VSV). Reads ON when the VSV opens the valve. When open, the A/C idle up valve bleeds a measured quantity of air from the intake manifold, which increases RPM at idle.

A/C LOAD(V)

Range: _____ 0.0 to 16.0 V

Indicates the air conditioning load signal voltage.

A/C MAG CLUTCH

Range: _____ ON/OFF

Indicates the status of the A/C compressor magnetic clutch. Reads ON when the clutch is engaged and reads OFF at all other times.

A/C PRESS(V)

Range: _____ 0.0 to 5.12 V

Indicates the voltage signal to the ECM from the A/C high-side pressure sensor.

High voltage equals high pressure; low voltage equals low pressure. See "A/C PRESS (psi)" below for calculated measurement information.

A/C RELAY

Range: _____ ON/OFF

Indicates the status of the air conditioning relay.

A/C RELAY

Range: _____ ON/OFF

Indicates a feedback signal from the A/C compressor clutch or relay, it reads:

- ON when the clutch is engaged
- OFF when the clutch is disengaged

A/C REQUEST**A/C REQUEST SW**

Range: _____ YES/NO or ON/OFF

Indicates the position of the air conditioning switch, it reads YES or ON when the A/C switch is turned on or when the ECM is commanding the A/C system to turn the compressor on. In some cases, the A/C compressor may not turn on even though the switch is set to on.

Several other switch or sensor signals may prevent the ECM from engaging the A/C compressor clutch. A reading of ON or YES means the switch is closed or the ECM has been commanded to turn on the A/C when all other conditions permit. Refer to "A/C CLUTCH" on page 335 for A/C compressor clutch feedback signal information.

A/C SW

Range: _____ ON/OFF

Indicates the status of the air conditioning switch.

A/C SWITCH

Range: _____ ON/OFF

Indicates the position of the air conditioning switch, it reads:

- ON when the air conditioning switch is on and all other in-series switches are closed
- OFF when any series switch in the air conditioning circuit is open

A/C SWITCH

Range: _____ 0.0 to 5.0 V

Indicates the air conditioning switch. The FI computer activates the compressor when a driver request for A/C ECU is received. While the compressor is operated, the engine load correction is performed.

A/C TEMP S (V)Range: _____ **0.0 to 5.0 V**

Indicates the air conditioner evaporator temperature sensor output voltage.

A/C TEMP S (°)Range: _____ **variable**

Indicates the ECM calculated air conditioner evaporator temperature.

A/F ADJ-B1**A/F ADJ-B2**Range: _____ **-0.330 to 0.330**

Indicates the correction of factor stored in ECM. The factor is calculated from the difference between the stored target air-fuel ratio and the air-fuel ratio calculated from A/F sensor 1.

A/F ALPHA-B1 (%)**A/F ALPHA-B2 (%)**Range: _____ **50 to 150%**

Indicates the mean value of the air-fuel ratio feedback correction factor per cycle.

A/F LEARNEDRange: _____ **YES/NO**

Indicates whether the block learn multiplier (BLM) is responding to the fuel integrator corrections. Use this reading to double-check the block learn response. Reads:

- YES when block learn is responding, or will respond, to integrator corrections
- NO when block learn is not responding to the integrator

In most cases, YES should display when the engine is in closed loop, and NO in open loop. However, this may vary with a few engine calibrations.

If the fuel integrator reaches its limit and block learn is not enabled (NO), the vehicle may have a driveability problem or it may return to open loop. Refer to "INTEGRATR" on page 404 and "BLM" on page 353 for more information.

A/F LEFT (V)**A/F RIGHT (V)****TARGET A/F (V)**Range: _____ **0.0 to 5.0 V**

Indicates the amount of correction necessary to the basic fuel-injection duration to maintain the desired air-fuel ratio.

A/F LEFT and A/F RIGHT provide air-fuel correction information for vehicles with two banks of injectors (V-type engines). TARGET A/F provides air-fuel correction information for vehicles with a single bank of injectors (in-line engines).

The ECM responds to this correction information according to five programmed routines:

Table 18-1 A/F program routines

Data	ECM Compensation	Engine Condition
0.00 V	Go leaner 10–20%	Rich
1.25 V	Go leaner 4–10%	Normal
2.50 V	Lean/rich $\pm 3\%$	Normal
3.75 V	Go richer 4–10%	Normal
5.00 V	Go richer 10–20%	Lean

A/F RATIO**A/F RATIO(:1)**Range: _____ **0.0 to 99.9**

Indicates the calculated desired air-fuel ratio that the PCM expects during a closed loop operation on some fuel-injected vehicles. This is not a measured value, but the calculated value of the ratio that the PCM wants to be delivered based on sensor input signals.

Although the measurement range is from 0.0 to 99.9, the displayed value should be near 14.7 in most cases. Lower numbers indicate a rich ratio commanded for startup. Higher numbers indicate a leaner ratio.

A/F RATIORange: _____ **Min.: 0 ,Max.: 1.999**

Indicates the air-fuel ratio. Typical readings range from 0.8 to 1.2 with the engine running at idle.

A/F SSR TEST B1Range: _____ **COMPL/INCMPL**

Indicates check mode result for air-fuel ratio sensor (bank 1).

A/F SSR TEST B1Range: _____ **COMPL/INCOMPL**

Indicates the check mode test results for the bank 1 air fuel ratio sensor.

A/F SSR TEST B2Range: _____ **COMPL/INCOMPL**

Indicates the check mode test results for the bank 2 air fuel ratio sensor.

A/F SSR TEST B2Range: _____ **COMPL,INCMPL**

Indicates check mode result for air-fuel ratio sensor (bank 2).

A/T D SWITCH**A/T D SWT**Range: _____ **ON/OFF**

Indicates the status of the A/T D position switch. Reads ON only when the shift selector lever is in the D position.

A/T D3 SWITCHRange: _____ **ON/OFF**

Indicates the status of the A/T D3 position switch. Reads ON only when the shift selector lever is in the D3 position.

A/T D4 SWITCHRange: _____ **ON/OFF**

Indicates the status of the A/T D4 position switch. Reads ON only when the shift selector lever is in the D4 position.

A/T R SWITCHRange: _____ **ON/OFF**

Indicates the status of the A/T R position switch. Reads ON only when the shift selector lever is in the Reverse position.

AATRange: _____ **-40 to 389°F or -40 to 199°C**

Indicates the ambient air temperature.

ABSOL PRES (V)Range: _____ **0.0 to 5.00 V**

Indicates the absolute pressure (ABSOL PRES) sensor signal voltage, which is determined by the MAP/BARO solenoid. See MAP/BARO SOLENOID for more information.

ABSOTPB(%)Range: _____ **0 to 100%**

Indicates the absolute throttle position as a percentage.

ABV VAC(%)Range: _____ **0 to 100%**

Indicates the air bypass valve solenoid (vacuum) control status as a percentage.

ABV VENT(%)Range: _____ **0 to 100%**

Indicates the air bypass valve solenoid (vent) control signal status as a percentage.

AC (CMPL)**CAT (CMPL)****CAT MONITOR****COMP MON****EGR (CMPL)****EVAP (A/FS) (CMPL)****EVAP MONITOR****FUEL SYS (CMPL)****HEATER CAT (CMPL)****MISFIRE (CMPL)****O2S (A/FS) MONITOR****O2S (A/FS) HTR (CMPL)****O2S (A/FS) (CMPL)****SEC AIR MONITOR****SEC AIR (CMPL)**Range: _____ **COMPL/INCMPL**

These parameters are part of the readiness monitors used to determine if the OBD-II self-diagnostics test has been run and/or the resulting status of the test.

AC (ENA)**CAT (ENA)****COMP MON****EGR (ENA)****EVAP (A/FS) (ENA)****FUEL SYS (ENA)****HEATER CAT (ENA)****MISFIRE (ENA)****O2S (A/FS) (ENA)****O2S (A/FS) HTR (ENA)****SEC AIR (ENA)**Range: _____ **ENABLE/UNABLE**

These parameters are part of the readiness monitors used to determine if the OBD-II self-diagnostics test has been run and/or the resulting status of the test.

AC HI PRESS OPNRange: _____ **HI/NORM**

Indicates the state of the A/C secondary high pressure switch. The switch is normally open (NORM) and closes (HI) when high pressure is sensed.

AC_REQ_SIGRange: _____ **ON/OFF**

Indicates the air conditioning request signal status.

AC MON CMPLRange: _____ **COMPLETE/INCOMPLETE**

Indicates the A/C monitor.

AC MON ENARange: _____ **UNABLE/ENABLE**

Indicates the A/C monitor.

ACC RELAYRange: _____ **OFF/ON**

Indicates the status of the accessory relay, PID displays ON when the ACC relay is on.

**ACCEL ENRICH
POWER ENRICH**Range: _____ **YES/NO**

Indicates whether the ECM is momentarily increasing injector pulse width to obtain a richer mixture during acceleration. Normally reads NO, reads YES only during enrichment.

ACCEL IDL POSRange: _____ **ON/OFF**

Indicates whether or not accelerator pedal position sensor detecting idle: ON: Idling.

ACCEL LRN VAL #1**ACCEL LRN VAL #2**Range: _____ **0 to 124.512**

Indicates the ETCS accelerator pedal sensor fully closed learned position value.

ACCEL LRN VAL#1**ACCEL LRN VAL#2**Range: _____ **Min.: 0 V, Max.: 124.512 V**

Indicates the accelerator fully closed learning value Number 1 and Number 2.

ACCEL POS1(%)Range: _____ **Min.: 0 %, Max.: 100 %**

Indicates the Absolute Accelerator Pedal Position (APP) Number 1.

- 10 to 25 %: Accelerator pedal released
- 60 to 90 %: Accelerator pedal fully depressed

ACCEL POS2(%)Range: _____ **Min.: 0 %, Max.: 100 %**

Indicates the Absolute Accelerator Pedal Position (APP) Number 2.

- 20 to 45 %: Accelerator pedal released
- 80 to 100 %: Accelerator pedal fully depressed

ACCEL POS1(V)Range: _____ **Min.: 0 V, Max.: 4.98 V**

Indicates the Absolute Accelerator Pedal Position (APP) sensor Number 1 voltage.

- 0.5 to 1.1 V: Accelerator pedal released
- 2.6 to 4.5 V: Accelerator pedal fully depressed

ACCEL POS2(V)Range: _____ **Min.: 0 V, Max.: 4.98 V**

Indicates the Absolute Accelerator Pedal Position (APP) sensor Number 2 voltage.

- 1.2 to 2.0 V: Accelerator pedal released
- 3.4 to 5.0 V: Accelerator pedal fully depressed

ACCEL SSR #1 AD(V)Range: _____ **Min.: 0 V, Max.: 4.98 V**

Indicates the accelerator fully closed value Number 1 (AD).

ACPPA(%)Range: _____ **0 to 100%**

Indicates the status of tolerator pedal position A.

ACPPB(%)Range: _____ **0 to 100%**

Indicates the status of tolerator pedal position B.

ACCSRange: _____ **ON/OFF**

Indicates the status of the air conditioning compressor cycling switch.

ACCS=A/CRange: _____ **ON/OFF**

Indicates the position of the air conditioning cycle switch (ACCS). Reads ON if the A/C switch on the instrument panel is on, or the PCM is commanding the A/C compressor on. In some cases, the A/C compressor may not turn on even though the switch is closed. Several other switch or sensor signals may prevent the PCM from engaging the A/C compressor.

ACM BATTERY VOLTAGERange: _____ **0.0 to 14.5 V**

Indicates the battery input voltage supplied to the ACM control module.

ACMRLYRange: _____ **ON/OFF**

Indicates the state of the AC main relay.

ACPRange: _____ **OPEN/CLOSED**

Indicates the air conditioning pressure switch.

ACSWRange: _____ **ON/OFF**

Indicates the air conditioning switch.

ACT VLV TMNG(°)Range: _____ **not available**

Indicates the actual valve timing.

ACT VSV (ON/OFF)Range: _____ **ON/OFF**

Indicates the A/C cut status for active test data support.

ACTUAL CKPRange: _____ **0 to 255**

Indicates whether the 7X synchronization pulses from the ignition module are being received by the PCM.

ACTUAL CMPRange: _____ **0 to 255**

Indicates a count of the signal pulses to the PCM from the camshaft position (CMP) sensor. The count changes continually as the engine runs.

ACCEL POS1 (%)**ACCEL POS2 (%)****APP (%)****APP1 (%)****APP2 (%)****APP3 (%)****APP SENSOR 1 (%)****APP SENSOR 2 (%)**Range: _____ **0 to 100%**

Indicates the accelerator pedal position (APP) as a percentage, it normally reads:

- 0% at idle
- 100% at wide open throttle (WOT)

The value should increase smoothly as the accelerator pedal moves from closed to full throttle.

Some models use three APP sensors, they are located in a module at the base of the accelerator pedal. During normal operation, the PCM only uses the APP1 sensor input, the other two serve as fail safe sensors.

ACCEL SSR #1 AD(V)Range: _____ **0.0 to 4.98V**

Indicates the ETCS accelerator sensor fully closed value Number 1 (AD).

ACIS VSVRange: _____ **ON/OFF**

Indicates the current state of the ACIS (Acoustic Control Induction System) vacuum switching valve. This valve controls the IACV (Intake Air Control Valve) in response to engine load. This increases intake efficiency when the throttle is open 60% or more and RPM is above 4,700. During this time the IACV is open (VSV/OFF), all other times the IACV is closed (VSV/ON).

ACG Control**ALT CTRL**Range: _____ **0.0 to 14.5 V**

Indicates the calculated output control signal that regulates the charging system rate. The PGM-FI detects electric power consumption, then calculates and controls charging using the generated electric power signal (ACGF) from ACG. During discharge, the ON time of the ACG generated electric power signal increases. The charging system is at maximum output (14.5 V) when the reading is 0 V, and minimum output (12.5 V) when the reading is battery voltage (B+). The battery charging voltage is controlled in either 12.5V mode or 14.5V mode, depending on the electric load conditions.

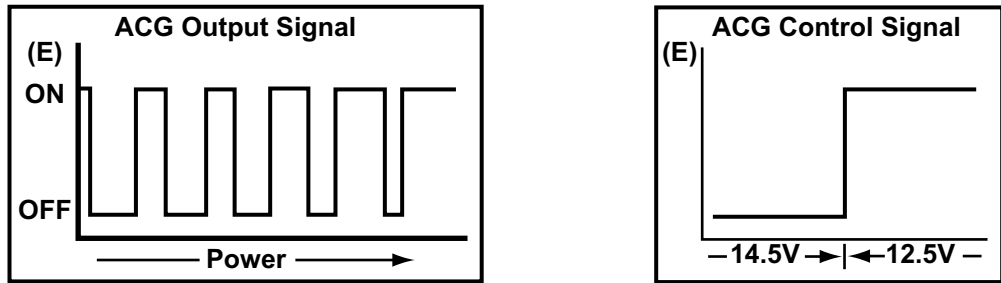

Figure 18-2 ACG output signal and ACG control signal

ACM(%)
 Range: _____ **0 to 100%**

Indicates the ECM signal to the active control motor mounts. The active control motor mounts are used to dampen vibration under certain engine idle or load conditions.

AF B1 HEATER
AF B2 HEATER
AF B1 S1 HEATER
AF B2 S1 HEATER
 Range: _____ **ON/OFF**

Indicates the A/F sensor heater status, it turns off if the battery voltage is above 16 volts. Reads ON when the heater is on, usually at idle with a cold exhaust. Cylinder bank 1 (B1) contains cylinder #1. Sensor 1 (S1) is upstream, closest to the engine.

AF B1 LAMBDA
AF B2 LAMBDA
AF LAMBDA
AF LAMBDA B1
AF LAMBDA B2
 Range: _____ **0.0 to 99.9**

Indicates the A/F Sensor equivalence ratio, which is the measured air/fuel ratio divided by the stoichiometric A/F ratio. A value greater than 1 indicates lean operation, and values less than 1 indicates rich operation. B1 and B2 provide information for vehicles with two banks of injectors.

AF FB
AF FB (ST FUEL TRIM)
AF FB (ST FUEL TRIM) B1
AF FB (ST FUEL TRIM) B2
 Range: _____ **0.0 to 99.9**

Indicates the A/F ratio feedback corrective commands from the ECM. The reading is the air fuel ratio feedback coefficient.

AF FB AVG
AF FB AVG (LT FUEL TRIM)
AF FB AVG (LT FUEL TRIM) B1
AF FB AVG (LT FUEL TRIM) B2
 Range: _____ **0.0 to 99.9**

Indicates the A/F ratio feedback average, which is derived from the short term fuel trim value and it is used for long-term correction of fuel delivery. The reading is the air-fuel ratio feedback coefficient value.

AF FB CMD**AF FB CMD B1****AF FB CMD B2**

Range: _____ **0.0 to 99.9**

Indicates the A/F ratio feedback command, which is the target air/fuel ratio that ECM is trying to maintain based on sensor data. Readings should be between 14.2 and 15.2 at idle. B1 or B2 provide information for vehicles with two banks of injectors.

AF FB COND

Range: _____ **OPEN/CLOSED**

Indicates the Air/Fuel Ratio Feedback Condition, it displays the current loop operating status.

AF SENSOR**AF SENSOR (mA)****AF SENSOR B1****AF SENSOR B2**

Range: _____ **0.0 to 99.9**

Displays from the air-fuel ratio (A/F) sensor signal, which detects exhaust gas oxygen content.

AI STATUS

Range: _____ **OK/NG**

Indicates the status of the air injection system based on pressure sensor feedback to monitor air flow pressure and volume.

AICV VSV

Range: _____ **ON/OFF**

Indicates the current state of the AICV (Air Intake Control Valve). This valve controls the AICV in response to engine air demand. When the throttle is open 60% or more and RPM is above 3,600, the AICV is open (ON) to allow extra intake air. At all other times the AICV is closed (OFF).

AIR CONTRL SOL

Range: _____ **ON/OFF**

Indicates the air control (secondary air injection) solenoid valve status. Reads ON when secondary air is routed to the exhaust port.

AIR CONTRL SOL**AIR DIVERT SOL**

Range: _____ **NORM/DIV or PORT/DIV**

Indicates the ECM command to the air injection control, or diverter, valve solenoid, it reads:

- NORM or PORT when the solenoid is commanded to move the valve to direct air downstream to the exhaust ports or the air switching solenoid
- DIV when the solenoid is commanded to move the valve to divert air to the atmosphere

AIR CONTRL SOL is displayed on vehicles with only a single air injection control solenoid. AIR DIVERT SOL is always displayed in conjunction with the AIR SWITCH SOL parameter on vehicles with two solenoids.

AIR INTAKE SOL

Range: _____ **ON/OFF**

Shows the ECM command to the secondary air intake valve to open the secondary runners:

- Reads ON when the ECM has commanded the solenoid to open the secondary valve
- Reads OFF when the ECM has not energized the solenoid to open the secondary valve (the engine is operating on the primary intake runners)

**NOTE:**

The engine must be warmed up, in closed loop, and operating with certain combinations of speed, throttle opening, and load before AIR INTAKE SOL will read ON.

This is an output signal from the ECM only, it does not indicate whether the solenoid has responded, or whether the valve has in fact opened.

AIR PMP PRS (kPa)

Range: _____ **0 kPa to 320 kPa**

Indicates the AIR PUMP absolute pressure. This is normally atmospheric pressure + 2.5kPa or more when the AIR PUMP is on and the air switching valve is open. The system is closed to atmospheric pressure when the AIR PUMP is OFF and the air switching valve is closed.

AIT PMP PLS PRS(kPa)

Range: _____ **0 kPa to 639.9 kPa**

Indicates the AIR PUMP pulsation pressure. This is cumulative pressure calculated by the ECM.

AIR PUMP

Range: _____ **not available**

Indicates secondary air injection pump amperage. The reading is based on the electric current sensor signal.

AIR PUMP

Range: _____ **ON/OFF**

Indicates the status of the AIR pump relay control circuit, it reads:

- ON when the PCM grounds the AIR pump relay control circuit
- OFF when the PCM disables the ground circuit

AIR PUMP RELAY

Range: _____ **ON/OFF**

Indicates the state of the AIR pump relay, it reads ON when the pump motor is on.

AIR PUMP SIGNAL

Range: _____ **LOW/HIGH**

Indicates the output voltage of the AIR pump motor, it reads LOW when the pump is on.

AIR SWITCH SOL

Range: _____ **PORT/CONV**

Indicates the ECM command to the air injection switching solenoid, it reads:

- PORT when the solenoid has been commanded to move the valve to direct air to the exhaust ports or manifold.
- CONV when the solenoid has been commanded to move the valve to direct air downstream to the catalytic converter.

AIR TEMP (°)

IAT (°)

IAT 1

IAT 2

IAT SENSOR 1 (°)

IAT SENSOR 2 (°)

INTAKE AIR (°)

INTAKE AIR TEMPERATURE SENSOR(2)Range: _____ **variable**

Indicates the intake air temperature (IAT) in degrees. Degree readings are PCM calculated from the IAT sensor (1 or 2) signal. Typical ranges are -58°F to 360°F (-50°C to 185°C). Readings should be low on a cold engine and rise as the engine warms up.

AIRFLOW (Hz)Range: _____ **0 to 1600 Hz**

Indicates the volume of intake air to the engine, as Hertz it reads:

- From 25 to 50 Hz at idle (700 RPM)
- From 70 to 100 Hz at 2000 RPM depending on engine displacement

AIRFLOW (mS)Range: _____ **0 to 625 mS**

Indicates the volume of intake air to the engine as milliseconds.

AIRFLOW (g/s)Range: _____ **0 to 500 g/s****AIRFLOW (m³/h)**Range: _____ **0 to 255 m³/h****AIRFLOW (kg/h)**Range: _____ **0 to 408 kg/h**

Indicates the amount of air flowing into the engine. The ECM calculates this value of intake airflow based on the MAF sensor output. Readings, which display as grams-per-second (g/s), cubic meters-per-hour (m³/h), or kilograms-per-hour (kg/h) should be low at idle and increase as the throttle opens.

AIRFLOW (V)**AIRFLOW (mV)**Range: _____ **0.0 to 5.0 V**

Indicates the volume of intake air entering the engine, it reads:

- A 5 V when there is no airflow.
- A 0 V at maximum airflow.

As air volume increases, the voltage output decreases.

AIRFLOW RESETRange: _____ **ON/OFF**

Indicates the state of the airflow reset function on some turbocharged vehicles, this function resets the airflow sensor when there is a change from high-speed, heavy-load driving to sudden deceleration. Reads ON only when airflow reset is activated.

AKNOCK**AKNOCK-1****AKNOCK-2**Range: _____ **not available**

Indicates the status of the knock sensor signal.

ALL_LAMPSRange: _____ **ON/OFF**

Indicates the status of all warning lamps.

ALL_SEGRange: _____ **not available**

Indicates the status of all segments.

ALTERNATORRange: _____ **0 to 100%**

Indicates the rate of alternator charging voltage as a percentage of maximum output. This indicates the magnetization ratio of the alternator.

ALTF(%)Range: _____ **0 to 100%**

Indicates the generator field current control duty signal status.

ALTT(V)Range: _____ **0.0 to 16.0 V**

Indicates the generator output voltage.

AMBIENT TEMPRange: _____ **-40 to 419°F or -40 to 215°C**

Displays the air temperature outside of the vehicle. A fixed reading of -40°F or -40°C indicates an open sensor circuit. A fixed reading of 419°F or 215°C indicates a shorted sensor circuit.

AMBIENT TEMPRange: _____ **Min.: -40°F, Max.: 258°F or Min.: -40°C, Max.: 215°C**

Indicates the ambient temperature: actual outside atmospheric temperature.

APP 1 (V)**APP 2 (V)****APP 3 (V)****APS****APP SENSOR 1 (V)****APP SENSOR 2 (V)**Range: _____ **0.0 to 5.0 V**

Indicates the accelerator pedal position (APP) as voltage, it should read:

- About 0.35–0.95 V at idle
- Above 4.0 V at wide open throttle

Some models use three APP sensors, they are located in a module at the base of the accelerator pedal. The ECM only requires information from one sensor, the other two serve as a fail safe.

APP 1&2 AGREE**APP1/APP2 AGREE****APP1/APP3 AGREE****APP2/APP3 AGREE**Range: _____ **YES/NO**

Indicates the results of a control module test that compares signals from one specific accelerator pedal position (APP) sensor to another specific APP sensor, it reads:

- YES if the sensor signals agree and correspond to the same accelerator pedal positions.
- NO if the sensor signals disagree and correspond to different pedal positions.

APP AVE

Range: _____ **0 to 125 counts**

Indicates the accelerator pedal position (APP) as step counts. The TAC Module takes the voltages from the 3 APP sensors, averages the readings and converts the readings into counts. The average number of counts is different on every vehicle.

APP CTP SW

Range: _____ **ON/OFF**

Indicates the status of the accelerator pedal position (APP) switch, it reads:

- ON when the accelerator pedal is released.
- OFF when the accelerator pedal is depressed.

APP SENSOR (°)**APP SENSOR 1 (°)****APP SENSOR 2 (°)**

Range: _____ **0 to 180°**

Indicates the accelerator pedal position (APP) as degrees of throttle opening.

APP SENSOR-A (V)

Range: _____ **0.0 to 5.0 V**

Indicates the voltage signal from accelerator pedal position (APP) sensor A, the sensor is a potentiometer connected to the accelerator cable.

APP SENSOR (V)**APP SENSOR B (V)****APP SENSOR-B (V)**

Range: _____ **0.0 to 5.0 V**

Indicates the voltage signal from accelerator pedal position (APP) sensor B, the sensor is a potentiometer connected to the accelerator cable. It should read half the voltage value of APP sensor A.

APP(%)

Range: _____ **0 to 100%**

Indicates the accelerator pedal position.

APP1 (V)**APP2 (V)****APP3 (V)**

Range: _____ **0.0 to 5.0 V**

Indicates the voltage signal from accelerator pedal position (APP) sensors.

Table 18-2 APP sensor voltage

Parameter	Accelerator Pedal At 0% (Pedal At Rest)	Accelerator Pedal At 100% (Pedal Fully Depressed)
APP1(V)	Less than 1.1 V	More than 2.0 V
APP2(V)	More than 3.9 V	Less than 3.0 V
APP3(V)	More than 3.2 V	Less than 3.5 V

APP2(%)

Range: _____ **0 to 100%**

Indicates the accelerator pedal position sensor 2.

ARPMDES
 Range: _____ **variable**

Indicates the desired RPM.

ARPMDES
 Range: _____ **not available**

Indicates the PCM desired ancillary RPM, which is the engine speed required to maintain the vehicle speed being commanded by the speed control system.

ASCD OD CUT
OD CUT #1
 Range: _____ **ON/OFF**

Indicates a command to shift the transmission from overdrive into a lower gear while operating in cruise control mode. This command may be initiated by the driver pressing the acceleration switch on the cruise control console, or by the ECM, after sensing a loaded engine condition caused by up-hill acceleration. Reads ON when shifted into a lower gear.

ASD RELAY
 Range: _____ **ON/OFF**

Indicates the status of the auto shutdown relay, it should read ON whenever the engine is running. The ASD relay provides power to the fuel pump, ignition coil, and fuel injectors.

AST
 Range: _____ **actual**

Indicates the time since start in seconds.

ASYNCH PULSE
 Range: _____ **YES/NO**

Indicates the asynchronous pulse to the fuel injectors, which provides extra fuel when engine load and speed require it. Readings should be:

- YES when asynchronous pulse function is active
- NO when asynchronous pulse function is inactive

Because these extra pulses are not synchronized with regular injector pulses, they are called asynchronous.

AT Lockup A or B
 Range: _____ **ON/OFF**

Indicates the status of the lockup solenoids. Solenoid valve A determines the lockup status. Lockup control is on when solenoid coil A is activated. Solenoid valve B controls the lockup area (low, middle, high) in the lockup control ON range.

Table 18-3 AT Lockup A or B

Solenoid A	Solenoid B	Lockup Control
ON	OFF	Low Range
ON	Cycling ON/OFF	Middle Range
ON	ON	High Range

ATCHK
 Range: _____ **LOW/HIGH**

Indicates the status of the slow speed data link between PGM-FI and AVT, it is used to transmit a timing retard request or automatic transmission trouble codes.

ATF TEMP 1

Range: _____ **–40 to 419°F or –40 to 215°C**

Indicates the trans internal fluid temperature. A fixed reading of –40°C or –40°F would indicate an open sensor circuit, A fixed reading of 419°F or 215°C would indicate a shorted sensor circuit.

ATM PRESS

Range: _____ **0 to 37.0 inHG or 10 to 125 kPa**

Indicates the ECM calculated barometric (atmospheric) pressure reading from the ATM Press sensor voltage signal.

ATM PRESS

Range: _____ **Min.: 0 kPa, Max.: 150 kPa**

Indicates atmospheric pressure: Equivalent to atmospheric pressure (absolute pressure).

ATM PRESS(V)

Range: _____ **0.0 to 5.12 V**

Indicates the barometric (atmospheric) pressure (ATM) Press sensor provided, analog voltage parameter that varies directly with atmospheric (barometric) pressure.

The ECM uses the ATM Press sensor voltage and the manifold absolute pressure (MAP) sensor voltage to calculate the manifold vacuum and determine true absolute pressure.

Some systems do not have an ATM Press sensor. However, the ECM provides a BARO reading by sampling the MAP sensor reading with the key on and the engine off just before cranking. At this point, manifold pressure should equal, or be very close to, atmospheric pressure. The ECM also updates these BARO estimates when the engine is running by sampling MAP voltage when the engine is at wide-open throttle.

ATSDLB

Range: _____ **not available**

Indicates the status of the (H) serial data line between the fuel injection ECM and the TCM.

AUTO LRN TIMER

Range: _____ **ON/OFF**

Indicates whether the vehicle theft deterrent (VTD) is in learn mode or it has timed out. Reads ON when learn mode is active.

AUTO OIL

Range: _____ **ON/OFF**

Indicates the ECM command to the automatic engine oil feeder pump. The oil feeder pump moves reserve oil from the reservoir into the crankcase. It Reads ON when the ECM has commanded the pump to run.

B/FUEL SCHDL (msec)

Range: _____ **???**

Indicates the base fuel schedule at the moment a malfunction is detected. "Base fuel schedule" indicates the fuel injection pulse width programmed into ECM, prior to any learned onboard correction. When engine is running, specification range is indicated in "SPEC".

B1S1 HTR AMPS**B1S2 HTR AMPS****B2S1 HTR AMPS****B2S2 HTR AMPS**

Range: _____ **0.0 to 1.5 A**

Indicates heated oxygen sensor (HO2S) B1S1, B1S2, B2S1 and B2S2 heater element current, which is low when heater circuit resistance is high. The heater current is high when circuit resistance is low.

B1S1 L-R (Sec)**B2S1 L-R (Sec)****B1S1 R-L (Sec)****B2S1 R-L (Sec)**

Range: _____ **0 to 1.000 sec**

Indicates the lean-to-rich (L-R) and rich-to-lean (R-L) oxygen sensor (O2S) switching times for bank 1 (B1) and bank 2 (B2). The ECM monitors for fluctuations in voltage ranging from greater than 0.600 V to less than 0.400 V.

The quicker the switching time, the better the condition of the O2S.

BACK-UP LIGHT SW

Range: _____ **ON/OFF**

Indicates the status of the back-up light switch, it reads ON when the back up lights are on.

BARO**BARO S****BARO Sensor****BARO TCM****BAROPRES**

Range: _____ **10 to 125 kPa, 400 to 850 mmHg or 0 to 37.0 inHg**

Indicates the ECM calculated barometric pressure expressed as kilo Pascal (kPa), millimeters of mercury (mmHg), or inches of mercury (inHg). the value is based on the BARO sensor voltage signal. Readings vary by altitude and ambient weather, expect to see about:

- 100 kPa (29.6 "Hg) at sea level
- 60 kPa (17.8 "Hg) at 14,000 feet

Compare BARO voltage and BARO pressure readings. Voltage should be high when pressure is high and low when pressure is low. If either, or both, of the readings appear abnormal for the expected local barometric pressure, the sensor signal to the ECM is inaccurate or the ECM calculations are incorrect for some reason.

BARO (V)**BARO S (V)****BARO SENSOR (V)**

Range: _____ **0.0 to 5.12 V**

Indicates the voltage signal from the barometric pressure (BARO) sensor. The reading should be high when barometric pressure is near atmospheric pressure at sea level. It should drop as barometric pressure drops.

The ECM uses the BARO sensor voltage and the manifold absolute pressure (MAP) sensor voltage to calculate the manifold vacuum and determine true absolute pressure.

Some systems do not have a BARO sensor. However, the ECM provides a BARO reading by sampling the MAP sensor reading with the key on and the engine off just before cranking. At this point, manifold pressure should equal, or be very close to, atmospheric pressure. The ECM also

updates these BARO estimates when the engine is running by sampling MAP voltage when the engine is at wide-open throttle.

BARO(Hz)

Range: _____ **125 to 160 Hz**

Indicates the barometric pressure as hertz.

BARO_EGR_SOL

Range: _____ **ON/OFF**

Indicates the BARO/SEGRP solenoid status.

BASADJ

Range: _____ **ON/OFF**

Indicates whether the BCM is in base idle adjustment mode, it reads ON when the ECM is in base idle air adjustment mode.

BATT (V)**BATTERY (V)**

Range: _____ **0.0 to 16.0 V**

Indicates vehicle battery voltage. The engine control system has no specific sensor to measure battery voltage, but some ECMs calculate this analog parameter from a sensing circuit across the supply voltage circuit.

The reading should be close to normal charging system regulated voltage with the engine running. This is typically 13.5 to 14.5 V at idle. Check the reading against actual voltage measured at the battery or alternator. Check vehicle specifications for exact values.

BATT TEMP (V)

Range: _____ **0.0 to 5.1 V**

Indicates a direct voltage reading from the battery temperature sensor, which is a variable resistor in parallel with a 5 V reference signal to the ECM.

Sensor voltage and temperature are inversely related. Low temperature produces high voltage; high temperature produces low voltage.

BATT TEMP (°)

Range: _____ **-40 to 199°C or -40 to 389°F**

Indicates the approximate temperature of the battery. The ECM uses the battery temperature sensor signal to regulate the charging system. The ECM charges a cold battery at a higher rate than a warm battery.

The ECM uses the battery voltage parameter for self-diagnostics. Some ECM functions are modified if voltage falls too low or rises too high. For example, if voltage drops below a minimum value, the ECM attempts to recharge the battery by increasing idle speed. This may affect the idle speed control, fuel metering, and ignition timing parameters.

BBP SENSOR

Range: _____ **variable**

Indicates the brake boost pressure sensor (booster pressure) signal expressed as kilo Pascal (kPa), millimeters of mercury (mmHg), or inches of mercury (inHg).

BLM BLOCK LEARN

Range: _____ **0 to 255**

Indicates whether the ECM is commanding a rich or a lean mixture. The block learn multiplier (BLM) number represents the operation and long-term correction of the fuel metering of some fuel-injected engines.

Like "INTEGRATR" on page 404, the BLM number can range from 0 to 255. The midpoint is 128. A BLM number higher than 128 indicates that the ECM commanded a long-term rich mixture correction. A BLM number lower than 128 indicates that the ECM is commanding a lean mixture (Figure 18-3).

The BLM number follows the integrator number and makes long-term corrections to fuel metering in response to short-term integrator changes. For example, integrator and block learn may both start at 128. The integrator number may move up toward or above 130. At that point, the BLM number may move up to 129. The integrator then returns to 128 to indicate that it is controlling fuel metering at the midpoint of an overall richer operating condition. A similar action occurs when the ECM commands a leaner mixture and the numbers move downward. Refer to "INTEGRATR" on page 404 for more information.

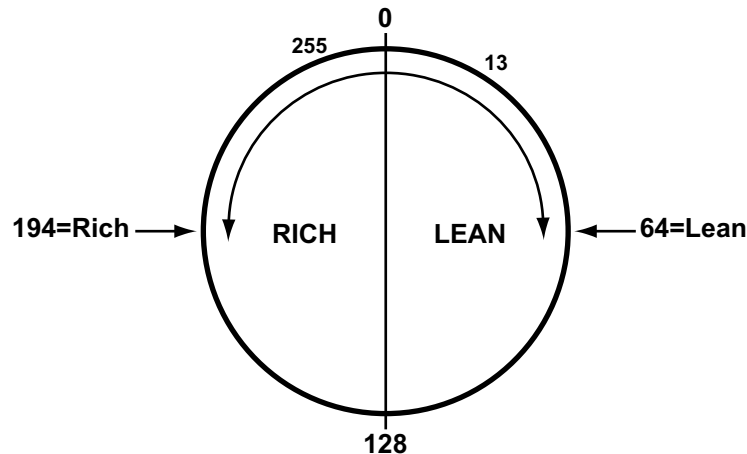

Figure 18-3 Rich/lean correction from base midpoint (0)

Depending on the vehicle, block learn is stored in either volatile or nonvolatile ECM memory.

If BLM is stored in volatile memory, the values are erased when the engine is turned off and returned to 128 when the engine is restarted. If BLM is stored in nonvolatile memory, the values are retained when the engine is turned off and returned to the stored values when the engine is started. Disconnecting the battery or removing the ECM fuse erases nonvolatile memory and returns BLM value to 128.

Compare BLM numbers to injector on-time. Numbers above 128 indicate increased on-time, while numbers below 128 indicate decreased on-time. BLM corrections operate only in closed loop. In open loop, the number goes to a fixed value, usually 128.

BLM CELL

Range: _____ **0 to 15**

Indicates which block learn multiplier (BLM) cell the engine is operating in at the moment.

The BLM is divided into 16 cells, numbered from 0 to 15. The cells are arranged in a theoretical grid, four or five high and four or five wide. The height represents engine load from low to high, and the width represents engine speed from low to high. Any combination of engine load and

speed fits into one of the 16 cells in the theoretical grid. Some fuel control programs do not use all 16 cells.

BLOCK F INFO

Range: _____ not available

Indicates the block F Information (H) data.

BLOWER FAN SW

Range: _____ ON/OFF

Indicates the blower motor switch.

BOO

BrakeOnOff

BRAKE SW

BRAKE SWITCH

BRAKE SWITCH B

BRAKE SWT

Range: _____ ON/OFF

Indicates the status of the brake pedal switch, it reads:

- ON when the brakes are applied
- OFF when the brakes are not applied

BOO=BRAKE SW

Range: _____ ON/OFF

Indicates the status of the brake on/off (BOO) switch. It reads ON when the ECM has recognized a 4-3 downshift, which should unlock the torque converter clutch on some models. When ON, related parameters should be:

- 4-3 DOWNSHIFT reads YES
- TCC COMMAND reads OFF.

BOOST PRS VSV

BOOST VSV

Range: _____ ON/OFF

Indicates the ECM command to the turbocharger wastegate control (BOOST) valve vacuum switching valve. Reads ON when the VSV opens the wastegate valve.

BOOST SENSOR

Range: _____ variable

Indicates turbocharger boost pressure inside the intake manifold, it should read:

- Close to barometric pressure at idle
- High when the engine is fully loaded WOT
- Zero during closed throttle deceleration

BPA

Range: _____ ON/OFF

Indicates the brake pressure applied switch.

BRAKE BOOSTER PRESS SENSOR

Range: _____ 8.9 to 3.4 V, 10 to 101 kPa or 3 to 20 inHg

Indicates the negative pressure (vacuum) or the relative voltage of the negative pressure internal to the brake booster assembly.

BRAKE SW1**BRAKE SW2**Range: _____ **ON/OFF**

Indicates brake switch (BRAKE SW1) and stop lamp switch (BRAKE SW2) status, which are input to the automatic speed control system.

B1S1 L-R(Sec)**B2S1 L-R(Sec)****B1S1 R-L(Sec)****B2S1 R-L(Sec)**Range: _____ **0 to 1.000 sec****O2 LR B1S1(ms)****O2 LR B2S1(ms)****O2 RL B1S1(ms)****O2 RL B2S1(ms)**Range: _____ **0 to 1000 ms**

Indicates the lean-to-rich (L-R) and rich-to-lean (R-L) oxygen sensor (O2S) switching times for bank 1 (B1) and bank 2 (B2). The ECM monitors for fluctuations in voltage ranging from greater than 0.600 V to less than 0.400 V.

BYPASS AIRRange: _____ **ON/OFF**

Indicates the secondary air injection bypass.

BYPASS AIR 1Range: _____ **ON/OFF**

Indicates the secondary air injection bypass 1.

C SHAFT SPD (km.h) (MPH)Range: _____ **0 to vehicle max.**

Indicates the vehicle speed calculated from the countershaft RPM on a manual transmission.

C.C. CANCEL HISTORYRange: _____ **0000(H) to 8000(H)**

Indicates the cruise control cancel history, which shows the reason why cruise control was canceled. The "C.C. CANCEL HISTORY.1" data is the latest data, possible readings are:

- 000(H): NO DATA
- 0001(H): MAIN SW OFF = Main switch was pressed
- 0002(H): BRAKE PEDAL = Brake pedal was pressed.
- 0004(H): GEAR/CLUTCH PDL: AT = Except D range. MT = Clutch pedal was pressed.
- 0008(H): C.C. CANCEL SW ON = Cancel switch was pressed.
- 0010(H): VSA/ABS ACT = VSA/ABS control was active.
- 0020(H): SET/RES SW & BRAKE pressed at the same time.
- 0040(H): CAN COM: CAN communication problem
- 0080(H): Out of Vehicle SPD: Vehicle speed is out of control.
- 0100(H): IHCC COM ERROR: Communication error with IHCC control module.
- 0200(H): Vehicle SPD ERROR: Vehicle speed data in ECM is error.
- 0400(H): Accel ERROR: Abnormal acceleration or deceleration.
- 0800(H): 1ST GEAR: Drive with 1st gear position.
- 1000(H): IHCC request: Cancellation request from IHCC.

- 2000(H): ENGINE PROBLEM: Engine problem.
- 4000(H): Vehicle SPD ERROR: Vehicle speed memory in ECM is error.
- 8000(H): IHCC ERROR: IHCC control module failed

CACBYP

Range: _____ ON/OFF

Indicates the charge air cooler solenoid valve.

CALC B1 TWC(°)

Range: _____ 572 to 1949°F or 300 to 1065°C

Indicates the temperature of the bank 1 catalytic converter as calculated by the control module based on various systems inputs. The scan tool will display a higher value at higher catalytic converter temperatures. The scan tool will display lower values at lower catalytic converter temperatures.

CALC B2 TWC(°)

Range: _____ 572 to 1949°F or 300 to 1065°C

Indicates the temperature of the bank 2 catalytic converter as calculated by the control module based on various systems inputs. The scan tool will display a higher value at higher catalytic converter temperatures. The scan tool will display lower values at lower catalytic converter temperatures.

CALC CAT TMP

Range: _____ 572 to 1949°F or 300 to 1065°C

Indicates the PCM calculated catalytic converter temperature on some vehicles. The calculations are based on sensor inputs for exhaust oxygen content, engine coolant temperature, load, speed, and other values.

CALC LOAD(%)

Range: _____ Min.: 0 %, Max.: 100 %

Indicates the calculated load by ECM.

- 15.0 to 35.0 %: Idling
- 10.0 to 30.0 %: Running without load (2,000 rpm)

CALC VACUUM

Range: _____ 0 to 80 kPa or 0 to 24 inHg

Indicates the PCM-calculated intake manifold vacuum, which is directly related to engine load. The lower the displayed value, the greater the engine load.

CAL ID

Range: _____ 1111111 to 9999999

Indicates the ECM calibration ID number, which is used for service identification.

CAL/LD VAL(%)**CAL/LD VALUE****CALC LOAD (%)**

Range: _____ 0 to 100%

Indicates a PCM calculated relative engine load, which is derived by dividing the actual manifold airflow volume by the maximum possible manifold airflow volume.

A high number indicates a heavy load, a low number a lighter load.

**CALC CLSD THRT
IDLE SW
IDLE SWITCH**Range: _____ **ON/OFF or CLSD/OPEN**

Indicates the position of the idle switch:

- CLSD or ON at closed throttle, typical of a stationary, idling engine
- OPEN or OFF when the throttle is off idle

Idle speed control on engines using the IDLE SW parameter are not regulated by the ECM. The CALC CLSD THRT parameter is calculated by the ECM based on throttle position sensor input.

**CAM HI TO LO
CAM LO TO HI**Range: _____ **0 to 65535**

Indicates a count of the number of camshaft position (CMP) sensor signal changes as voltage goes from low to high.

CAM PHASE ACT (°)Range: _____ **0 to 25°**

Indicates the actual PCM commanded camshaft retard in degrees.

CAM PHASE DES (°)Range: _____ **0 to 25°**

Indicates the PCM desired camshaft phase angle.

CAM PHASE DUTY (%)Range: _____ **0 to 100%**

Indicates the duty cycle the PCM is applying to the camshaft phase solenoid to achieve desired cam retard or advance.

CAM PHASE VARIRange: _____ **0 to 25%**

Indicates the difference in degrees between the desired and actual camshaft angle.

**CAM SENSOR
CRANK SENSOR**Range: _____ **YES/NO**

Indicates the status of the camshaft position (CMP) and crankshaft position (CKP) sensor signals used in direct ignition systems (DIS). The CMP signal is used for fuel injection timing and cylinder identification. The CKP signal is used to control fuel injection quantity and determine engine speed and spark advance.

When starting or running the engine, these parameters read YES. These parameters are useful when troubleshooting a no-start problem.

CAN CIRC 1
CAN CIRC 2
CAN CIRC 3
CAN CIRC 4
CAN CIRC 5
CAN CIRC 6
CAN CIRC 7
CAN CIRC 8
CAN CIRC 9

Range: _____ **UNKNOWN/NORM(OK)**

Indicates the condition of controller area network (CAN) circuits 1 to 9.

CAN CTRL VSV

Range: _____ **ON/OFF**

shows the status of the EVAP canister control vacuum switching valve, which is used for active test support.

CASeGND (V)

Range: _____ **-16.0 to 16.0 V**

Indicates the voltage difference between the PCM case ground and the hardwired fuel level input from the fuel pump driver module.

A typical reading is 0.027 V, values above 0.050 V indicate high resistance.

CAT CMPL

Range: _____ **COMPLETE/INCOMPLETE**

Indicates the catalyst monitor status.

CAT MON TEMP

CAT MONITOR CONDITION

CAT MONITOR CONDITION B1

CAT MONITOR CONDITION B2

Range: _____ **OK/NG**

Indicates the catalytic monitoring system temperature condition, which indicates the capability to detect catalytic system deterioration.

CAT ENA

Range: _____ **UNABLE/ENABLE**

Indicates the catalyst monitor status.

CAT MONITOR

COMPONENT MONITOR

EVAP MONITOR

FUEL SYS MONITOR

MISFIRE MONITOR

O2S(A/FS) MONITOR

SEC AIR MONITOR

Range: _____ **COMPLETE/INCOMPLETE or AVAILABLE/NOT AVAILABLE**

These parameters are part of the readiness monitors used to determine if the OBD-II self-diagnostics test has been run and/or the resulting status of the test.

CAT OT FC CYL#1
 CAT OT FC CYL#2
 CAT OT FC CYL#3
 CAT OT FC CYL#4
 CAT OT FC CYL#5
 CAT OT FC CYL#6
 CAT OT FC CYL#7
 CAT OT FC CYL#8

Range: _____ OFF/ON

Indicates if Catalyst Over Temp protection Fuel Cut for that cylinder is active (reads ON).

CAT TEMP B1S1
 CAT TMP B1S1
 CAT TEMP B1S2
 CAT TMP B1S2
 CAT TEMP B2S21
 CAT TMP B2S1
 CAT TEMP B2S2
 CAT TMP B2S2

Range: _____ -40 to 11,756.3°F or -40 to 6,513.5°C

Indicates the calculated temperature of the catalyst substrate for the indicated cylinder bank or oxygen sensor. For example, B1S1/B2S2 is the reading from bank 1 sensor 1 which is the upstream O2S. B1S2/B2S2 is the reading from bank 1 sensor 2, which is the downstream O2S. Temperature readings of 400°C to 800°C indicate a properly warmed-up catalyst.

CAT_mon_ready

Range: _____ YES/NO

Indicates that the catalyst efficiency monitor has successfully completed.

CATEMP11

Range: _____ -40 to 11,756.3°F or -40 to 6,513.5°C

Indicates the catalyst temperature for bank 1, sensor 1.

CATEMP21

Range: _____ -40 to 11,756.3°F or -40 to 6,513.5°C

Indicates the catalyst temperature for bank 1, sensor 2.

CC ENGAGED

Range: _____ YES/NO

Indicates the status of the cruise control switch it reads:

- YES when the cruise control switch is on and the set/coast switch is activated
- NO when the cruise control switch is on and the set/coast switch is released

CC INHIBITED

Range: _____ YES/NO

Indicates the PCM commanded operating state of the cruise control system, it reads:

- YES when cruise is inhibited
- NO when cruise is not inhibited

CC ON/OFF SW
CC RES/ACC
CC RES/ACC SW
CC SET/CST SW

Range: _____ **ON/OFF or YES/NO**

Indicates the current state of the cruise control switches, it should read:

- ON or YES when the circuits are closed
- OFF or NO when the circuits are open

The resume (RES) accelerate (ACC) and the set coast (CST) switches are in parallel to each other and in series with the On/Off switch.

The CC RES/ACC and CC SET/CST parameters should only read YES when CC ON/OFF reads ON. If the CC ON/OFF parameter reads OFF, the CC RES/ACC and CC SET/CST parameters should both read NO.

CCM CMPL

Range: _____ **COMPLETE/INCOMPLETE**

Indicates the comprehensive component monitor.

CCM ENA

Range: _____ **UNABLE/ENABLE**

Indicates the comprehensive component monitor.

CCP COMMAND

Range: _____ **ON/OFF**

Indicates the ECM output signal to the charcoal canister purge (CCP) valve. It reads ON when the ECM has de-energized the solenoid to allow purging, and reads OFF when the solenoid is energized to prevent purging.

CCSFault

Range: _____ **YES/NO**

Indicates the presence of a fault in the coast clutch solenoid circuit. It only reads YES when a circuit fault is present.

CDCV

Range: _____ **ON/OFF**

Indicates the canister drain cut valve control signal.

CHASSIS PITCH

Range: _____ **YES/NO**

Indicates the pitch status of the chassis, it reads:

- YES when pitch conditions exist
- NO when pitch conditions do not exist

CHECK MODE

Range: _____ **OFF/ON**

Indicates check mode. ON: Check mode ON.

CHIME

Range: _____ **ON/OFF**

Indicates the chimer control.

CHRGLP
Range: _____ **ON/OFF**

Indicates the generator warning light status.

CHT
CHT SENSOR
Range: _____ **-40 to 399°F or -40 to 199°C**

Indicates the cylinder head temperature.

CHT_FAULT
Range: _____ **YES/NO**

Indicates the cylinder head temperature status.

CHTIL
Range: _____ **ON/OFF**

Indicates the operating status of the cylinder head temperature indicator lamp (CHTIL) and should only read ON if the lamp is on.

CHTIL_FAULT
Range: _____ **YES/NO**

Indicates the cylinder head temperature indicator lamp status.

CKP A NO PULSE
CKP B NO PULSE
CKP NO PULSE
Range: _____ **0 to 255**

Indicates the crankshaft position sensor A (or B) disappearance counter (Counts).

CKP A NOISE
CKP B NOISE
CKP NOISE
Range: _____ **0 to 255**

Indicates the crankshaft position sensor A (or B) noise counter (Counts).

CKP RESYNCS
Range: _____ **0 to 255**

Indicates a count of the number of times the PCM had to synchronize the crankshaft position (CKP) sensor.

CKP SENSOR(RPM)
Range: _____ **variable**

Indicates the engine speed based on the signal from the crankshaft position (CKP) sensor.

CLEAR FLOOD
Range: _____ **YES/NO**

Indicates whether the ECM is operating in clear flood mode, and only reads YES when clear flood is active. On many fuel-injected engines, the ECM responds to engine cranking with a wide-open throttle by commanding a clear flood mode, which provides a very lean air-fuel mixture to help clear a flooded engine.

CLR DIST
Range: _____ **actual**

Indicates the distance since the diagnostic trouble codes were cleared.

CLUTCH SWITCHRange: _____ **ON/OFF**

Indicates the state of the clutch pedal position switch, it reads ON when the clutch pedal is depressed and the switch is electrically closed.

CLVRange: _____ **0 to 100%**

Indicates the PCM calculated load value. This percentage, current air flow divided by peak air flow, indicates the capacity of the engine load. Normal readings at idle are 10 to 35%.

CMP 1 NO PULSE**CMP 2 NO PULSE****CMP A NO PULSE****CMP B NO PULSE****CMP NO PULSE (COUNTS)**Range: _____ **not available**

Indicates the camshaft position (CMP) sensor disappearance counter (Counts).

CMP NOISE 1**CMP NOISE 2****CMP A NOISE****CMP B NOISE**Range: _____ **not available**

Indicates the camshaft position (CMP) 1 (or 2) noise counter. This counter detects the noise compared with CKP sensor 1 (or 2).

CMP CTRL CMD (°)Range: _____ **0 to 180°**

Indicates the camshaft position sensor control command. The ECU calculates the target angle of the camshaft, and uses it to regulate the VTC control valve solenoid.

CMP CTRL (°)Range: _____ **0 to 180°**

Indicates the camshaft position sensor control in degrees, which is the cam angle controlled by the camshaft actuator.

CMP RESYNCSRange: _____ **0 to 255**

Indicates a count of the number of times the PCM had to synchronize the camshaft position (CMP) sensor.

CMP SENSOR(RPM)Range: _____ **variable**

Indicates the engine speed based on the signal from the camshaft position (CKP) sensor.

CMP_FAULTRange: _____ **YES/NO**

Indicates the camshaft position sensor status.

CoastCISolRange: _____ **ON/OFF**

Indicates the PCM command to the coast clutch solenoid, which allows engine braking in third gear when fourth gear is enabled by the transmission control switch. Reads ON when the coast clutch solenoid is activated.

CoastCISol (mA)Range: _____ **0 to 1000 mA**

Indicates the actual current of the PCM output to the coast clutch solenoid in milliamperes. When activated, coast clutch solenoid allows engine braking in third gear when fourth gear is disabled by the transmission control switch.

COLD STARTUPRange: _____ **YES/NO**

Indicates whether the engine is operating in cold-start mode. A cold-start is when the engine coolant temperature (ECT) rises above a predetermined temperature during an ignition cycle. During the next ignition cycle, the ECT should be below the predetermined point.

Also, the ECT and the intake air temperature (IAT) are less than 122°F (50°C) and are within 5°F (3°C) of each other at start-up. When the above is true, the display reads YES.

COLPRange: _____ **ON/OFF**

Indicates the refrigerant pressure switch (middle pressure) status.

COMMEGR(%)Range: _____ **0 to 100%**

Indicates the commanded EGR status.

COMMEVAP(%)Range: _____ **0 to 100%**

Indicates the commanded evaporative purge.

COMMTAC(%)Range: _____ **0 to 100%**

Indicates the commanded throttle actuator control.

COMPONENT MONITORRange: _____ **NOT AVAILABLE/AVAILABLE**

Indicates the comprehensive component monitor.

COND FANRange: _____ **ON/OFF**

Indicates the FAN signal.

COND FAN LORange: _____ **ON/OFF**

Indicates the FAN 1 control signal.

COOL FAN(%)Range: _____ **0 to 100%**

Indicates the duty cycle on engines that control the engine fan by pulse-width modulation. As the commanded state increases, so does the percentage of ON time the duty cycle percent is proportional to the fan speed:

- A low reading indicates a low fan speed.
- A high reading indicates a high fan speed.
- 0% indicates the fan is off.

**COOLANT (°)
COOLANT TEMP
ECT (°)**

Range: _____ **-40 to 199°C or -40 to 389°F**

Indicates the ECM calculated engine coolant temperature (ECT) in degrees based on the ECT sensor signal. The sensor is a thermistor installed in the engine coolant passages.

Typical readings for a fully warmed engine running at idle are 185° to 220°F (85° to 105°C). A reading of -40°C or -40°F may indicate an open in the sensor or the sensor circuit. A reading above 185°C or 366°F may indicate a short in the sensor or the sensor circuit.

COOLANT (V)

Range: _____ **0.0 to 5.1 V**

Indicates the voltage signal from the engine coolant temperature (ECT) sensor.

Sensor voltage and temperature are inversely related. A low temperature produces a high voltage signal, and a high temperature produces a low voltage signal.

COOLANT TEMP

Range: _____ **Min.: -40°F, Max.: 258°F or Min.: -40°C, Max.: 140°C**

Indicates the engine coolant temperature. 80 to 105°C (176 to 221°F): After warming up.

- If value -40°C (-40°F): sensor circuit open
- If value 140°C (284°F): sensor circuit shorted

**COOLING FAN
LOW RAD FAN
FAN CTRL
HIGH RAD FAN**

Range: _____ **ON/OFF or OFF/LOW/HIGH**

Indicates the ECM command to operate the radiator cooling fan. The LOW RAD FAN and HI RAD FAN parameters refer to one fan with two speed settings.

CPP

Range: _____ **RELEASED/DEPRESSED**

Indicates the clutch pedal position switch

CPP_SW

Range: _____ **RELEASED/DEPRESSED**

Indicates the clutch pedal position switch.

CRANK

Range: _____ **YES/NO**

Indicates whether the ignition switch cranking circuit is closed through the starter motor solenoid, it reads:

- YES when the cranking circuit is closed and the engine is cranking
- NO when the circuit is open

The CRANK signal causes the ECM to shut down temporarily as the engine cranks because power cannot be ensured with the high current draw of the starter.

CRANK #2 RPM

Range: _____ **0 to 2000 rpm**

Indicates the speed of the camshaft as determined by the CMP and CKP sensor signal, it is used in direct ignition systems (DIS).

CRANK REQUESTRange: _____ **YES/NO**

Indicates the PCM request to engage the cranking relay and power the starter, it only reads YES when the ignition switch is in the crank position.

CRANKINGRange: _____ **ON/OFF**

Indicates the position of the ignition switch, it reads:

- ON when the ignition switch is in the crank (start) position
- OFF at all other times

The ECM uses this signal to control the fuel injection, idle speed, and ignition timing during engine cranking.

CRANKING RPMRange: _____ **0 to 800 rpm**

Indicates engine RPM while the starter is cranking. The ECM uses this information to calculate fuel metering for the best air-fuel ratio at starting. You this parameter to check cranking performance or troubleshoot starting problems.

CRUISE BRAKE SWRange: _____ **ON/OFF**

Indicates state of the brake switch for cruise control, it reads ON when the brake pedal is depressed.

CRUISE CANCEL SWRange: _____ **ON/OFF**

Indicates the status of the cruise control cancel switch, it reads ON when the cruise control cancel switch is pressed.

CRUISE CONTROLRange: _____ **ON/OFF**

Indicates the cruise control state, it reads ON when the cruise control is active.

CRUISE INDICATOR**CRUISE LAMP****CRUISE LIGHT**Range: _____ **ON/OFF**

Indicates whether the cruise control lamp is on or off. When using cruise control ECM turns on the cruise control light on the instrument panel.

CRUISE MAIN SW**CRUISE MASTER (MAIN) SWT****CRUISE SW****MAIN SW**Range: _____ **ON/OFF**

Indicates the status of the cruise control main switch, it reads ON when the switch is turned on and electrically closed.

When this switch is on, it sends a signal to the throttle actuator control (TAC) Module that allows all other cruise control functions.

CRUISE RESUME SWTRange: _____ **ON/OFF**

Indicates the status of the cruise control resume switch, it reads ON when the switch is turned on and electrically closed.

CRUISE SET SWTRange: _____ **ON/OFF**

Indicates the status of the cruise control set switch, it reads ON when the switch is turned on and electrically closed. The Cruise Control light on the dash should also be on.

CRUS REQ TH (°)(%)Range: _____ **0 to 180° or 0 to 100%**

Indicates the throttle valve position requested by the cruise control module.

CTP**CTP (APS)****CTP SW**Range: _____ **ON/OFF or OPEN/CLOSED**

Indicates the closed throttle position (CTP) status, it should read:

- ON or CLOSED with a closed throttle
- OFF or OPEN whenever the throttle is opened

The ECM uses this parameter to cut fuel delivery and lean the mixture during deceleration within certain RPM ranges. This parameter may be ECM-calculated based on the throttle position (TP) sensor or it may have a separate CTP switch integrated into the TP sensor.

CURRENT SENSOR (V)Range: _____ **not available**

Indicates the voltage signal from the air pump electric current sensor.

CYLRange: _____ **6 5 4 3 2 1**

Indicates each cylinder. The displayed number shows each cylinder.

CYL 1 (2, 3, 4, 5, or 6) MISFIRERange: _____ **actual**

Indicates the cylinder misfire counter (counts). It indicates the number of misfires that occurred at the specific cylinder.

Cyl. DEACT. PERFORMANCE TSTRange: _____ **OFF/ON**

Indicates ON if all the Displacement On Demand (DOD) enabling conditions are met. The parameter displays OFF if one or more enabling conditions are out of range.

CYL DEACT SYSTEM COMMANDRange: _____ **V4/V8**

Indicates the current status of the total number of cylinders being commanded to be active.

CYL #1 (%)

CYL #2 (%)

CYL #3 (%)

CYL #4 (%)

CYL #5 (%)

CYL #6 (%)

CYL #7 (%)

CYL #8 (%)

CYL x MISFIRESRange: _____ **0 to 100%**

Indicates the misfire rate detected in cylinders 1 to 8 expressed as a percentage the previous 1000 crankshaft revolutions.

A 0% reading means no misfires occurred during the past 1000 crankshaft revolutions.

The "x" in CYL x MISFIRES is a variable from 1 to 8, indicating the cylinder being monitored.

CYL #1 (%)

CYL #2 (%)

CYL #3 (%)

CYL #4 (%)

CYL #5 (%)

CYL #6 (%)

CYL #7 (%)

CYL #8 (%)

Range: _____ **Min.: 0, Max.: 255**

Indicates misfire ratio of cylinder 1 to 8. This item displays only when idling.

CYL 1 DEACT SOL COMMANDRange: _____ **ON/OFF**

Indicates the current status of cylinder 1. Reads OFF if the cylinder is being commanded to deactivate. By default, the cylinder is normally activated.

CYL 4 DEACT SOL COMMANDRange: _____ **ON/OFF**

Indicates the current status of cylinder 4. Reads OFF if the cylinder is being commanded to deactivate. By default, the cylinder is normally activated.

CYL 6 DEACT SOL COMMANDRange: _____ **ON/OFF**

Indicates the current status of cylinder 6. Reads OFF if the cylinder is being commanded to deactivate. By default, the cylinder is normally activated.

CYL 7 DEACT SOL COMMANDRange: _____ **ON/OFF**

Indicates the current status of cylinder 7. Reads OFF if the cylinder is being commanded to deactivate. By default, the cylinder is normally activated.

CYL ALL MISS RATERange: _____ **Min.: 0, Max.: 255**

Indicates all cylinders misfire rate: 0 to 35.

CylHdTemp (V)**CHTS(V)**Range: _____ **0.25 to 4.75 V**

Indicates cylinder head temperature expressed as voltage. The higher the voltage, the lower the temperature.

D SWITCHRange: _____ **ON/OFF**

Indicates the transmission Drive range switch status.

D/C Converter Control ELD Unit**ELD**Range: _____ **not available**

Indicates the total vehicle electric load based on current in the main power harness. This value is taken from the electric load detector (ELD) sensor signal, which is installed on the main fuse box.

D/C CTRL VOL (V)Range: _____ **0.0 to 25 V**

Indicates the battery charging voltage of the D/C converter in standard (14.5 V) mode.

D/M MUFFLER SWRange: _____ **ON/OFF**

Indicates the status of the muffler mode changeover switch on the Mitsubishi 3000GT Turbo and Dodge Stealth turbo with a dual-mode (D/M) muffler, it reads:

- ON when the switch is in the TOUR position
- OFF when the switch is in the SPORT position

A valve in the main muffler inlet switches between two different inlet apertures: a large aperture (sport mode) for improved fuel consumption and driveability and a smaller aperture (tour mode) for quieter operation at lower engine RPM. The changeover switch is located on the dash.

DAMPING CTRLRange: _____ **ON/OFF**

Indicates the damping control status. The damping control eases the fluctuation in revolution speed with a IMA motor, it reads ON when the function is active.

DBW (drive by wire)Range: _____ **not available**

Indicates the calculated volume of idle airflow with the accelerator pedal fully closed as counts. The greater the number of counts, the more the idle air passage is open.

DCRKMFRange: _____ **not available**

Indicates the crankshaft sensor for misfire detection disconnect counter.

DCT_CNTRange: _____ **actual**

Indicates the number of trouble codes set.

DECEL ENLEAN**DECEL FUEL C/OFF****FC AIRFLOW**Range: _____ **YES/NO or ON/OFF**

Indicates whether the ECM is reducing injector pulse width to create a lean air-fuel mixture for deceleration, it should read:

- YES or ON during deceleration
- NO or OFF during all other conditions

Lean mixtures, or fuel cutoff, on deceleration help to prevent high HC emissions and allow the engine to return to a 14.7:1 idle air-fuel ratio more quickly. Reduced fuel flow also helps to prevent stalling at idle from an overly rich mixture.

DECHOKE

Range: _____ **YES/NO**

No additional information is available for this parameter.

DES IDLE RPM**DESIRED IDLE**

Range: _____ **0 to engine max.**

Indicates the desired idle RPM the PCM is attempting to maintain.

If there is a large difference between actual and desired idle readings, the ECM may have reached its control limit without being able to control the idle speed. This may be due to either a basic mechanical or electrical problem with the engine.

DESIRED FAN RPM

Range: _____ **0 to fan max.**

Indicates the desired fan speed the PCM is attempting to maintain. The PCM compensates for various engine loads based on engine coolant temperature in order to keep the fan at the desired speed by turning on the fan clutch and monitoring the fan speed sensor.

DESIRED TP (%)

Range: _____ **0 to 100%**

Indicates the desired throttle angle that the PCM is trying to maintain. Compare the actual and desired throttle position readings. They should be equal or close to each other.

DIST DTC CLEAR

Range: _____ **Min.: 0 km/h, Max.: 65,535 km/h**

Indicates distance after DTC cleared: Equivalent to drive distance after DTCs erased.

DISTANCE SINCE DTC CLEARED

Range: _____ **variable**

Indicates the distance accumulated since an emission diagnostic trouble code was cleared. The distance displayed will increase as the vehicle is driven.

DOWNLVR

Range: _____ **ON/OFF**

Indicates the status of the gear shifter (Slap Shift).

- ON when selector lever is – side
- OFF when selector lever is other than the above

DPFE (V)

Range: _____ **0.45 to 4.60 V**

Indicates the differential pressure feedback EGR (DPFE) sensor signal, which reflects exhaust pressure. The PCM uses DPFE to compute optimum EGR flow.

Pressure feedback EGR systems control EGR flow rate by monitoring pressure drop across a remotely located sharp-edged orifice. There are several sensor designs, some have an aluminum housing and use a 0.55 V offset, others have an aluminum or plastic housing and use a 1.0 V offset. Typically, sensor output should be as shown in the table below:

Table 18-4 Typical sensor outputs for DPFE parameter

0.55 Volt Offset			1.0 Volt Offset		
inHg	kPa	Volts	inHg	kPa	Volts
8.83	29.81	4.66	8.56	28.9	4.95
6.62	22.36	3.64	4.3	14.4	2.97
4.41	14.90	2.61	0	0	1.0
2.21	7.46	1.58			
0	0	0.55			

DPFEGR

Range: _____ not available

Indicates the delta feedback pressure exhaust gas recirculation.

DRIVE Count**DRIVECNT**

Range: _____ 0 to 255

Indicates the number of times the engine has been started since the last DTC P1000 (monitor readiness) set.

DRIVE DIST (km)(mile)

Range: _____ actual distance

Indicates the drive distance.

DRIVE TIME (min)

Range: _____ actual minutes

Indicates the total drive time in minutes.

DRV STATUS

Range: _____ IDLE, F/C, or F/C DECEL

Indicates the control status of the vehicle, reading are:

- IDLE during idling control
- F/C during fuel cut control
- F/C DECEL during fuel cut control on deceleration.

DTC CouNT**DTC_CNT**

Range: _____ 0 to 255

Indicates the DTC count. The count includes DTC needing no action.

DTC STORED

Range: _____ actual count

Indicates the total number of current DTCs set this ignition cycle.

E-ABV STEPS**E-ABV STEP POS**

Range: _____ 0 to 125

Indicates the position of the supercharger bypass valve stepper motor. Reads 125 when the valve is fully open, and 0 when closed.

EACV

Range: _____ **0 to 100%**

Indicates electrical current to the EACV (the variable solenoid valve that controls engine idle speed). The current increases with intake airflow. The EACV is duty cycle controlled.

EC IGN RLY

Range: _____ **ON/OFF**

Indicates the commanded state of the engine control (EC) or PCM ignition relay control circuit. The scan tool will display On or OFF. On indicates the EC ignition relay control circuit is being grounded by the control module, allowing voltage to the ignition system. OFF indicates the EC ignition relay is not being commanded by the control module.

EC IGN RLY FBK

Range: _____ **variable**

Indicates the voltage signal sent to the control module from the engine control (EC) or PCM ignition relay. The scan tool will display battery voltage when the engine is running. The scan tool will display no voltage when the relay is OFF.

ECONO LIGHT

Range: _____ **ON/OFF**

Indicates the status of the economy light. The light is turned ON when the fuel system is in the lean-burn zone.

ECRK1**ECRK2**

Range: _____ **not available**

Indicates the crankshaft sensor 1 (or 2) disconnect/noise counter for V6 engines.

ECT

Range: _____ **-40 to 399°F or -40 to 199°C**

Indicates the engine coolant temperature.

ECT 1 (°)**ECT SENSOR (°)**

Range: _____ **-40 to 199°C or -40 to 389°F**

Indicates the engine coolant temperature (ECT) as degrees. The reading is calculated by the ECM based on the resistance value change of the NTC thermistor ECT sensor. Typical readings at idle are 70°C to 100°C (158°F to 212°F).

ECT 1 (V)**ECT SENSOR (V)****ECT (V)**

Range: _____ **0.0 to 5.0 V**

Indicates the engine coolant temperature (ECT) as voltage. The ECT is a thermistor installed in the engine coolant passages. A 5 V reference signal is applied to the ECT. As temperature increases, sensor resistance decreases to provide a variable voltage signal to the PCM. The PCM converts ECT sensor voltage to temperature.

Typical ECT readings are 0.70 V to 0.40 V on a warm engine at idle

ECT LAMP 1

Range: _____ **ON/OFF**

Indicates the status of engine coolant temperature lamp 1. This lamp turns ON when the engine coolant is "cold" (less than 56°C).

ECT LAMP 2Range: _____ **ON/OFF**

Indicates the status of engine coolant temperature lamp 2. This lamp flashes when the engine coolant is heated (above 118°C) and turns ON when it is overheated (above 124°C).

ECT_FAULTRange: _____ **YES/NO**

Indicates the engine coolant temperature status.

ECYL1**ECYL2**Range: _____ **not available**

Indicates the cylinder sensor 1 (or 2) disconnect/noise counter for V6 engines.

EGR BOOST SOLRange: _____ **ON/OFF**

Indicates the EGR boost sensor solenoid valve control signal.

EGR CMPLRange: _____ **COMPLETE/INCOMPLETE**

Indicates the EGR monitor.

EFE COMMANDRange: _____ **ON/OFF**

Indicates whether the ECM has commanded the early fuel evaporation (EFE) system to turn on, it should read:

- ON when the EFE system has received a signal to energize
- OFF when the system is de-energized to remove heat from the air-fuel mixture

The EFE system is used on carbureted engines to preheat the incoming air-fuel mixture for a cold engine. The EFE system may be a vacuum-operated manifold heat control valve or an electric grid heater under the carburetor.

This parameter is an output signal from the ECM only. It does not indicate whether the EFE system has responded.

EGR COMMAND**EGR SOLENOID****EGR SYS****EGR SYSTEM**Range: _____ **ON/OFF**

Indicates whether the ECM has commanded the EGR vacuum solenoid or vacuum switching valve (VSV) to open, should read:

- ON when the solenoid has received a signal to energize, open a vacuum line, and apply vacuum to the EGR valve
- OFF when the solenoid has been de-energized to cut off EGR vacuum

Typically, readings are OFF in park or neutral, at idle, or in open loop, and ON at cruising speed in closed loop.

These are output signals only. The reading does not indicate whether the solenoid or valve responded or whether the EGR valve actually opened.

EGR ENA
 Range: _____ **UNABLE/ENABLE**

Indicates the EGR monitor.

EGR L COM
EGR V L COMMAND
 Range: _____ **not available**

Indicates the ECM command for EGR valve lift.

EGR LIFT
 Range: _____ **not available**

Indicates the actual EGR valve lift subtracted from zero-lift, which is learned from the EGR valve life sensor.

EGR LIFT SENSOR
EGR VLS
 Range: _____ **0.0 to 5.0 V**

Indicates voltage changes in proportion to EGR valve position. As vacuum is applied to the diaphragm of the EGR valve, the lift amount of the EGR valve also increases.

EGR MON
 Range: _____ **COMPL/INCMP**

Indicates the status of the exhaust gas recirculation (EGR) system monitor. Reads COMPL (completed) if the monitor successfully ran, INCMP (incomplete) if not. This monitor is enabled during EGR operation after certain base operating conditions are satisfied.

EGR POS(%)
 Range: _____ **0 to 100%**

Indicates the exhaust gas recirculation valve position.

EGR POS(V)
 Range: _____ **0.0 to 5.0 V**

Indicates the exhaust gas recirculation valve position.

EGR STEPS
EGR STEP POS
 Range: _____ **0 to 125**

Indicates the position of the EGR valve stepper motor as counts. A 125 reading indicates the motor plunger is fully extended and the EGR valve is fully open.

EGR TEMP (V)
 Range: _____ **0.0 to 5.12 V**

Indicates a feedback signal from a thermistor mounted in the EGR passage, which reflects the amount of EGR flowing.

On most vehicles, a high voltage signal means a high EGR flow rate; low voltage means low or no EGR flow. However, on some 1996 and later Nissan vehicles, high voltage means a low flow rate; low voltage means high or no EGR flow.

EGR TEMP (°)
 Range: _____ **-50 to 320°C or -58 to 600°F**

Indicates EGR gas temperature based on the signal of a sensor located slightly downstream from the EGR control valve. A decrease in EGR temperature indicates either restricted EGR flow or a system malfunction.

EGR VAC SOL(%)	0 to 100%
Range: _____	
Indicates the exhaust has recirculation solenoid valve (vacuum) status.	
EGR VENT SOL(%)	0 to 100%
Range: _____	
Indicates the exhaust gas recirculation solenoid A.	
EGR_FAULT	YES/NO
Range: _____	
Indicates the exhaust gas recirculation status.	
EGRBARO	0.0 to 5.0 V
Range: _____	
Indicates the EGR BARO sensor voltage signal (BARO/SEGRP solenoid). The signal is used by the PCM to control EGR flow. The greater the EGR flow, the lower the voltage.	
EGRBARO	ON/OFF
Range: _____	
Indicates the BARO/SEGRP solenoid.	
EGRC SOLENOID	ON/OFF
Range: _____	
Indicates the ECM command to the EGR vacuum solenoid. Should read ON when the EGR valve is closed, and OFF when the EGR valve is open.	
EGRCFault	YES/NO
Range: _____	
Indicates whether the PCM detected a fault in the EGR control solenoid circuit that regulates vacuum to the EGR valve. YES means a fault is present.	
EGRFOpen	YES/NO
Range: _____	
Indicates whether the PCM has detected an open circuit in the EGR vacuum regulator valve or EVR circuit, YES means a fault is present.	
EGRFShort	YES/NO
Range: _____	
Indicates whether the PCM has detected a short circuit in the EGR vacuum regulator valve or EVR circuit, YES means a fault is present.	
EGRMDSD	variable
Range: _____	
Indicates the desired EGR motor position.	
EGRVFault	YES/NO
Range: _____	
Indicates whether the PCM detected a fault in the EGR vacuum solenoid circuit, YES means a fault is present.	
EGRVR (%)	0 to 100%
Range: _____	
Indicates the signal of the EGR valve position sensor as a percentage (EGR valve duty cycle percentage). A low reading indicates low EGR flow, a high reading indicates high EGR flow.	

EGRVR_FAULTRange: _____ **YES/NO**

Indicates the exhaust gas recirculation valve duty cycle status.

EGT SENSOR (V)Range: _____ **3.4 to 0.9 V****EGT SENSOR (°C) (°F)**Range: _____ **500 to 700°C, or 1060 to 1484°F**

Indicates the temperature of the exhaust gases either as the voltage signal from the exhaust gas temperature sensor, or as ECM calculated temperature.

ELEC LOAD**ELEC LOAD SIG****ELEC LOAD SW****LOAD SIGNAL**Range: _____ **ON/OFF**

Indicates the electrical load on the charging system (such as head lamps, brake lamps, rear defrost). The ECM uses this signal to compensate for electrical loading at idle, it reads:

- ON when certain combinations of accessories are on
- OFF when certain combinations of accessories are off

ElecPrsCtrlRange: _____ **0 to 100 psi**

Indicates the PCM commanded transmission electronic control pressure. This is a calculated parameter based on PCM-controlled Pulse-Width output.

ENG LOAD (%)Range: _____ **0 to 100%**

Indicates current engine operating load as a percentage of maximum engine load.

ENG RESTART CONDRange: _____ **OK/NG**

Indicates whether the engine can be restarted after the engine was shut down by the auto idling stop system.

ENG RUN TIMERange: _____ **Min.: 0 second, Max.: 65,535 seconds**

Indicates engine run time: Time after engine start that cycle.

ENG OIL PRESS SWRange: _____ **OFF/ON**

Indicates the presence of engine oil pressure. This should remain on from engine start to engine shut off.

ENG OIL TEMPRange: _____ **-40 to +419°F or -40 to +215°C**

Indicates the engine oil temperature in degrees Celsius or fahrenheit, which the PCM uses to control the cooling fans.

ENG ON RUN TIMERange: _____ **0 to 65,535 sec**

Indicates the time lapse since the engine was started during this key cycle.

ENG SPD

Range: _____ **0 to engine max.**

Indicates engine RPM. On most vehicles, the ECM relies on the engine speed sensor for this value. On others, the TCM internally calculates this parameter by directly monitoring the pulses of the ignition coil to determine engine speed.

ENG SPD FROM EFI**IAT FROM EFI****ECT FROM EFI****TPS FROM EFI****ACCEL POS FROM EFI**

Range: _____ **varies by system Min/Max**

Indicates processed data received from the Engine F/I control module by the Transmission control module, and is used to process upshift and downshift decisions. This should match data collected when monitoring Engine control module parameters.

ENG TORQ (N-M)

Range: _____ **0 to 65025 Nm**

Indicates engine torque as calculated by the PCM.

ENGINE LOAD (%)

Range: _____ **0 to 160%**

Indicates relative engine load based on engine speed (RPM), the number of cylinders, and manifold airflow. A high number indicates a heavy load; a low number, a light load.

ENGINE MOUNT

Range: _____ **IDLE/TRVL**

Indicates the state of the engine mount operation corresponding to the engine speed and the vehicle speed. The parameter reads as follows with the engine running:

- Idle (with vehicle stopped)—IDLE
- All other conditions—TRVL

ENGINE OIL LIFE

Range: _____ **not available**

No additional information is available for this parameter.

ENGINE OIL PRESSURE

Range: _____ **variable**

Indicates engine oil pressure as kilo Pascal (kPa), millimeters of mercury (mmHg), inches of mercury (inHg), and kilograms per square centimeter (kgf/cm²).

ENGINE RPM**RPM**

Range: _____ **0 to engine max.**

Indicates engine speed, which the PCM computes from the ignition reference pulses. Engine speed should remain close to desired idle under various engine loads with the engine idling.

ENGTRQ SIGNAL (%)

Range: _____ **0 to 100%**

Indicates engine torque as calculated by the ECM based on the MAP sensor value. The ECM transmits the signal to the motor control module.

EOP SENSOR (V)**EOP SENSOR (kgf/cm²)**Range: _____ **0.0 to 9.9 kgf/cm² or 0.0 to 5.0 V**

Indicates the engine oil pressure either as the engine oil pressure sensor signal voltage, or as an ECM calculated pressure. This value is used for the VPS.

EOT SENSOR (°C) (°F)Range: _____ **-40 to 199°C or -40 to 389°F****EOT SENSOR (V)**Range: _____ **0.0 to 5.0 V**

Indicates the engine oil temperature either as the engine oil temperature sensor signal voltage, or as an ECM calculated pressure.

EPC (V)Range: _____ **2.0 to 14.5 V**

Indicates the average operating voltage of the pulse-width-modulated electronic pressure control solenoid. A low average voltage reading indicates a higher EPC pressure; a higher reading indicates a lower EPC pressure.

EPS**EPS SIGNAL**Range: _____ **LOW/HIGH**

Indicates the voltage level of the EPS signal line. It only reads HIGH when electrical load of the EPS becomes higher than the specified value.

EQ RATRange: _____ **not available**

Indicates the desired equivalence ratio (Lambda).

EQ RAT11Range: _____ **not available**

Indicates the (A/F) ratio as commanded by the ECM for bank 1, sensor 1.

ESC ACTIVERange: _____ **YES/NO**

Indicates whether the ECM is controlling spark advance, it should read:

- YES after the engine starts and the ECM controls timing
- NO when the engine is cranking, the ignition module controls timing, and electronic spark timing is disabled

ESC COUNTERRange: _____ **0 to 255**

Indicates the relative duration and magnitude of spark knock as a count.

Any number greater than 0 indicates that knock occurred. A low number means short duration; a higher number indicates longer duration and magnitude.

ESC FAILURERange: _____ **YES/NO**

Indicates whether an electronic spark control failure was detected, it should read:

- YES when any of the ESC components fail, usually accompanied by trouble code 43.
- NO when the system is working properly

EST ECT (°C) (°F)

Range: _____ -40 to 199°C or -40 to 389°F

Indicates the estimated coolant temperature as calculated by the ECM.

ETC_ACT (°)

Range: _____ 0 to 100°

Indicates actual throttle plate opening in degrees. Readings of 6% or less reflect a closed throttle, and 85% or more reflects a wide open throttle.

ETC_DES (%)

Range: _____ 0 to 100%

Indicates the ECM desired throttle plate opening in degrees.

EVAP BYPASS SOL

Range: _____ ON/OFF

Indicates the status of the evaporative bypass solenoid valve. The EVAP 2-way valve is bypassed when the solenoid valve is controlled to ON.

EVAP CMPL

Range: _____ COMPLETE/INCOMPLETE

Indicates the EVAP monitor.

EVAP CVS VALVE**EVAP CVS VLV**

Range: _____ ON/OFF

Indicates the status of the evaporative canister vent shut solenoid valve. The valve closes the canister vent.

EVAP ENA

Range: _____ UNABLE/ENABLE

Indicates the EVAP monitor.

EVAP MON**EVAP mon ready**

Range: _____ COMPL/INCMP or YES/NO

Indicates the status of the evaporative emissions (EVAP) system monitor. Reads COMPL (completed) or YES if the monitor has completed or conditions for monitoring have been met. Reads INCMP (incomplete) or NO if the monitor has not completed or conditions for monitoring have not been met.

The sequence of events required to enable this monitor vary, depending upon the EVAP system components.

EVAP MONITOR

Range: _____ COMPLETE/INCOMPLETE

Indicates the EVAP monitor.

EVAP MONITOR

Range: _____ NOT AVAILABLE/AVAILABLE

Indicates the EVAP monitor.

EVAP PC DUTY (%)

Range: _____ 0 to 100%

Indicates the duty cycle of the evaporative purge control solenoid valve. This indicates the drive percentage of the purge control solenoid valve when on.

EVAP PC SOLRange: _____ **ON/OFF**

Indicates the status of the evaporative purge cut solenoid valve. The canister purging is accomplished by drawing fresh air through the canister and into a port on the throttle body when the solenoid is OFF.

EVAP PF SWRange: _____ **ON/OFF**

Indicates the status of the evaporative purge flow switch. This is the vacuum switch that detects EVAP purge line failure. The switch turns on when vacuum exists.

EVAP PRES (V)Range: _____ **0.0 to 5.0 V**

Indicates the pressure in the evaporative emissions (EVAP) purge line. As EVAP pressure increases, sensor voltage increases. The ECM uses this signal to detect pressure leaks and faulty components.

EVAP PURGE (%)Range: _____ **0 to 100%**

Indicates the pulse-width modulated duty cycle applied to the EVAP purge valve by the PCM. At 100%, the valve should be fully open to purge the system.

EVAP PURG(V)Range: _____ **0.0 to 5.0 V**

Indicates the evaporative emission canister purge valve voltage.

EVAP SOLENOID**PURGE VSV****PURGE SOL**Range: _____ **ON/OFF**

Indicates the PCM command status for the vacuum switching valve (VSV) or solenoid that controls the evaporative emission (EVAP) purge valve, reads ON when the system is purging.

EVAP TSTRange: _____ **PASS/FAIL**

Indicates whether the EVAP diagnostic monitor has successfully completed.

EVAP VENT SOLRange: _____ **ON/OFF**

Indicates the status of the EVAP vent solenoid, it should read:

- ON when the EVAP vent solenoid is closed to create a vacuum in the fuel tank
- OFF when the solenoid is open to allow purge

EVAPCPRange: _____ **ON/OFF**

Indicates the evaporative emission canister purge valve duty cycle. Displays whether the canister purge solenoid is on or off.

EVAPCP%Range: _____ **0 to 100%**

Indicates the evaporative emission canister purge valve duty cycle.

EVAPCPFault

Range: _____ **YES/NO**

Indicates whether the PCM detects a fault in the EVAP canister purge solenoid circuit. Reads YES if a fault is detected.

EVAPCV%**EVAPCV(%)**

Range: _____ **0 to 100%**

Indicates the duty cycle of the EVAP canister vent solenoid, which controls the amount of air entering the EVAP system:

- 0% indicates the solenoid is fully open
- 100% indicates the solenoid is fully closed

EVAPCVFault**EVAPCV_FAULT**

Range: _____ **YES/NO**

Indicates whether the PCM detects a fault in the canister vent solenoid circuit. Reads YES when a fault is present.

EVAPPrgFlw (V)

Range: _____ **0.0 to 5.0 V**

Indicates the presence of purge flow from the canister to the engine. Voltage should increase as purge flow increases:

- 0.4 to 1.3 V at idle
- 0.4 to 4.0 V at steady cruise

EVAPSOAK

Range: _____ **actual**

Indicates that the EVAP monitor soak time conditions have been met.

EVAPVM%

Range: _____ **0 to 100%**

Indicates the evaporative emission vapor management valve status.

EVAPVM_FAULT

Range: _____ **YES/NO**

Indicates the evaporative emission vapor management valve fault.

EVAPVMA

Range: _____ **ON/OFF**

Indicates the commanded state of the EVAPVM.

EVMV(A)

Range: _____ **not available**

Indicates the evaporative vapor management current.

EXH BYPASS VSV

Range: _____ **ON/OFF**

Indicates the ECM command to the vacuum switching valve (VSV), which actuates the second turbocharger wastegate control valve. It only reads ON when the VSV opens the second wastegate valve.

**EXH CTRL VSV
EXH GAS CTL VSV**Range: _____ **ON/OFF**

Indicates the ECM command to the vacuum switching valve (VSV), which actuates the second turbocharger exhaust gas control valve. It reads ON when the VSV opens the valve.

EXH V/T LEARNRange: _____ **YET/CMPLT**

Indicates the condition of Exhaust Valve Timing Control Learning.

- YET—Exhaust Valve Timing Control Learning has not been performed yet
- CMPLT—Exhaust Valve Timing Control Learning has already been performed successfully

EXHAUST OXYGEN**REAR O2****LEFT O2****RIGHT O2**Range: _____ **RICH/LEAN****F BNK UP****O2S #1 STATUS****O2S #2 STATUS****R BNK UP****REAR O2 STATUS**Range: _____ **RICH/CENTER/LEAN**

Indicates the general rich or lean condition of the exhaust as measured by the oxygen sensor (O2S). Exhaust oxygen content is related to oxygen content in the intake air-fuel mixture and thus indicates the intake air-fuel ratio.

The exhaust O2S is the primary sensor that indicates whether the engine is running rich or lean. The O2S must be hot (above 500°F/260°C), and the ECM must be in closed loop before the ECM responds to the sensor signal.

RICH or LEAN indicates the general condition of the exhaust. The O2 voltage indicates the exact sensor signal. Refer to “O2 (mV)” on page 420 for more information.

Some vehicles have separate oxygen sensors for the left and right banks, or front and rear banks on transverse-mounted V6 engines. Exhaust conditions from these sensors are shown as LEFT O2 and RIGHT O2, F BNK UP or R BNK UP (upstream), or EXHAUST OXYGEN and REAR O2. Some vehicles that have two sensors display them as O2S #1 and O2S #2, with #1 indicating the bank that contains cylinder number 1.

F INJECTOR (mS)Range: _____ **variable**

Indicates the operating status of the fuel injection and displays the open time length, in milliseconds, of an injector contained in bank 2 during valve pausing as commanded by the ACM control module.

FAIL #1**FAIL #2**Range: _____ **ON/OFF**

Indicates whether the PCM has executed a fail safe function.

FAIL #1**FAIL #2**

Range: _____ **ON/OFF**

Indicates whether the ETCS fail safe function was executed. If ON is displayed, then the ETC was/is in fail safe mode after detecting ETCS failure.

FAIL #1

Range: _____ **ON/OFF**

Indicates whether or not the fail safe function executed. ON: ETCS has failed.

FAIL #2

Range: _____ **ON/OFF**

Indicates whether or not the fail safe function executed. ON: ETCS has failed.

FAN 1

Range: _____ **ON/OFF**

Indicates the FAN1 control signal.

FAN 2

Range: _____ **ON/OFF**

Indicates the FAN2 control signal.

FAN 3

Range: _____ **ON/OFF**

Indicates the FAN3 control signal.

FAN CTRL ECT (°C) (°F) (V)

Range: _____ **variable**

Indicates the status of the fan control engine coolant temperature sensor as voltage or temperature. Voltage at idle should be from 1.4 to 0.6 V. (H.LIMIT) 158°F to 212°F, (L.LIMIT) 70°C to 100°C, and possible variance range is 8°C (at 100°C) and 14°F (at 212°F).

FAN HIGH CTRL**FAN LOW CTRL**

Range: _____ **ON/OFF**

Indicates the status of the fan high control. When the 2 stage radiator fan is controlled to high (low) mode by the ECM, the fan high control indicates ON.

FAN_DUTY(%)

Range: _____ **0 to 100%**

Indicates the variable fan duty cycle.

FAST IDLE SOL

Range: _____ **ON/OFF**

Indicates the status of the fast idle solenoid valve. It reads ON at low engine coolant temperatures when the PCM transmits a command to raise the idle RPM.

FAN MOTOR

Range: _____ **actual**

Indicates the status of the electrical fan motor for active test data support.

FAN SPEED (RPM)

Range: _____ **0 to fan max.**

Indicates the fan speed in RPM. The PCM controls the fan by modulating the fan clutch and monitoring the fan speed sensor.

FAT
Range: _____ **ON/OFF**

Indicates the DLC FAT terminal.

FAULT CODE DISPLAY
Range: _____ **actual**

Indicates the diagnostic trouble codes.

FC CTP
Range: _____ **ON/OFF**

Indicates the status of the ECM command to cut fuel (FC) during closed-throttle (CTP) deceleration. It reads ON when the ECM commands a fuel cut after sensing a closed throttle.

FC IDL
Range: _____ **ON/OFF**

Fuel cut idle: ON: Fuel cut operating, "ON" when throttle valve is fully closed and engine speed is over 2,800 rpm.

FC TAU
Range: _____ **ON/OFF**

Indicates fuel cut TAU (fuel cut during very light load). ON: Fuel cut operating. A fuel cut is being performed under very light load to prevent engine combustion from becoming incomplete.

FCIL
Range: _____ **ON/OFF**

Indicates the fuel cap off indicator lamp status.

FCIL_FAULT
Range: _____ **YES/NO**

Indicates a fuel cap off indicator lamp fault.

FIA CTRL SOL
Range: _____ **ON/OFF**

Indicates the status of the fuel injector air control solenoid valve. It is turned ON in order to better atomize the fuel under various driving conditions.

FlexFuel (Hz)
Range: _____ **-32512 to 32768 Hz**

Indicates the flexible fuel output frequency.

FLI
FLI (%)
FUEL SENDER (V)
FUEL LEVEL (V)(%)
FUEL LVL SENSOR (V)(%)
Range: _____ **0.0 to 5.0 V, 0 to 12 V or 0 to 100%**

Indicates the amount of fuel remaining in the tank as voltage or a percentage. Percent readings indicate current level to total capacity. Voltage readings should be:

- Below 1 V for an empty tank
- About 2.5 V or 6 V (depending on system) for a full tank

FLI_FAULT
Range: _____ **YES/NO**

Indicates the a flex fuel sensor fault.

FLUID TEM (V)

Range: _____ 0.0 to 5.0 V

Indicates the transmission fluid temperature voltage.

FP

Range: _____ ON/OFF

Indicates the fuel pump status.

FP (%)

Range: _____ 0 to 100%

Indicates the fuel pump status in percentage.

FP MODE

Range: _____ ON/OFF

Indicates the fuel pump has been turned on or off in response to a PCM command.

FP RES RELAY

Range: _____ ON/OFF

Indicates the fuel pump (FP) resistor relay status.

FP RLY

Range: _____ ON/OFF

Indicates whether the fuel pump relay has turned on or off in response to a PCM command.

FP SENSOR (kPa) (mmHg) (in.Hg) (V)

Range: _____ variable

Indicates pressure in the fuel rail as monitored by the fuel pressure sensor. This signal can determine fuel pressure regulator performance. At idle, pressure readings should be:

- 270 kPa to 360 kPa
- 2025 mmHg to 2700 mmHg
- 79 inHg to 106 inHG

FP_RLY

Range: _____ ON/OFF

Indicates the fuel pump relay status.

FPFault

Range: _____ YES/NO

Indicates whether the PCM has detected a fault in the fuel pump circuit.

FPFault reads YES when a fault is present.

FPM**FPMonitor**

Range: _____ ON/OFF

Indicates the fuel pump monitor.

FPTDR (V)

Range: _____ LOW/HIGH

Indicates the input level voltage level of the FPTDR line.

FR ACM SOL CURRENT

Range: _____ not available

Indicates the actual electric current applied to the front ACM control module as amperes.

FR ACM SOL MAX CURRENT**FR ACM SOL MIN CURRENT**Range: _____ **not available**

Indicates the maximum or minimum current applied to the front ACM control module for the ignition cycle as amperes.

FRP PSIRange: _____ **37 to 150 psi**

Indicates the fuel rail pressure.

FRP(V)Range: _____ **not available**

Indicates the fuel rail pressure voltage.

FRP_DSDRange: _____ **actual**

Indicates the fuel rail pressure desired.

FRP_FAULTRange: _____ **YES/NO**

Indicates a fuel rail pressure fault.

FRTRange: _____ **-40 to 399°F or -40 to 199°C**

Indicates the fuel rail temperature.

FRT(V)Range: _____ **0.0 to 5.0 V**

Indicates the fuel rail temperature voltage.

FRZSTR (1)Range: _____ **actual count**

Indicates the status of the freeze frame data as a count. A count is recorded every time the ECM stores freeze frame data.

FSS**FSS B1****FSS B2**Range: _____ **not available**

Indicates the status of the fuel system, which may be divided by cylinder banks (1 or 2).

FT CELLRange: _____ **0 to 23**

Indicates the fuel cell that the PCM is currently operating in, which is determined by manifold absolute pressure (MAP) and RPM inputs.

FT LEARNRange: _____ **ENABLED/DISABLED**

Indicates if conditions are appropriate for enabling long term fuel trim correction, reads:

- ENABLED when long term fuel trim is responding to the short term fuel trim
- DISABLED when long term fuel trim is not responding to in short term fuel trim

FT SENSOR (°C) (°F) (V)Range: _____ **variable**

Indicates the status of the fuel temperature sensor on the fuel rail. This indicates the temperature of the fuel in the fuel rail.

FTP SENSOR**FTP SNSR**Range: _____ **variable**

Indicates the status of the fuel tank pressure sensor on the fuel tank junction box as voltage or pressure. With no tank pressure (fuel fill cap open to atmosphere) reading should be:

- 0.6 kPa
- 4.5 mmHg
- 0.2 inHg
- 2.3V to 2.7V.

Minimum and maximum readings are:

- -8.3 kPa to 8.3 kPa
- -62 mmHg to 62 mmHg
- -2.5 inHg to 2.5 inHg
- 0.0V to 5.0V

FTP(V)Range: _____ **0.0 to 5.0 V**

Indicates the fuel tank pressure transducer voltage.

FTP_FAULTRange: _____ **YES/NO**

Indicates a fuel tank pressure transducer fault.

FTT SENSOR (°C) (°F) (V)Range: _____ **variable**

Indicates the temperature of the fuel in the fuel tank based on the fuel tank temperature sensor signal. The sensor is on the fuel tank junction box.

FUEL CMPLRange: _____ **COMPLETE/INCOMPLETE**

Indicates the fuel system monitor.

FUEL CUTRange: _____ **ON/OFF**

Indicates whether the PCM is commanding the fuel injectors to turn off. It reads ON when the command is cut fuel (injectors off), and OFF at all other times.

FUEL CUT DECEL**FUEL CUTOFF SOL**Range: _____ **ON/OFF**

Indicates whether the PCM is commanding the fuel injectors to turn off due to a deceleration condition. It reads:

- ON when the ECM energizes the solenoid to open the fuel line for normal delivery
- OFF when the ECM de-energizes the solenoid to close the fuel line and cut fuel delivery during deceleration

FUEL ENA
 Range: _____ **UNABLE/ENABLE**

Indicates the fuel system monitor. Reads ENABLE when the monitor is active.

FUEL (%) FRONT

FUEL (%) REAR

Range: _____ **-25 to +25%**

Indicates the adaptive adjustment made to fuel injector pulse width for the front and rear cylinder banks at idle. Should read:

- A negative value if the PCM is decreasing the pulse width from programmed values
- A positive value if the PCM is increasing the pulse width from programmed values

FUEL LEVEL (AVERAGE)

FUEL LEVEL (L)

Range: _____ **0 to 72 liters or 0 to 19 gallons**

Indicates the amount of fuel remaining in the tank.

FUEL LEVEL (mV)

Range: _____ **1000 to 6200 mV**

Indicates the amount of fuel remaining in the tank as millivolts:

- 1000mV to 3600mV indicates a full tank
- 2700mV to 6200 V indicates a near empty tank

FUEL LEVEL(V)

Range: _____ **0.0 to 5.0 V**

Indicates the fuel tank level signal voltage.

FUEL METER CTRL (%)

Range: _____ **0 to 100%**

Indicates the status of the fuel meter control, which represents the amount of fuel remaining in the fuel tank as a percentage of total capacity.

FUEL MISFIRE

Range: _____ **actual count**

Indicates the accumulated misfire counter for 2VI method fuel system problems.

FUEL PMP SP CTL

Range: _____ **LO/HI or ON/OFF**

Indicates the current state of the fuel pump relay.

The fuel pump supply voltage is controlled (LO/HI) by the ECM from the intake manifold pressure and engine RPM. The relay is turned ON at high fuel pump control mode.

FUEL PRES SOL

Range: _____ **ON/OFF**

Indicates the fuel pump regulator control.

FUEL PRESS(V)

Range: _____ **0.0 to 5.0 V**

Indicates the fuel tank level signal voltage.

FUEL PRS UP VSV

Range: _____ **ON/OFF**

Indicates the status of the fuel pressure up vacuum switching valve.

FUEL PUMPRange: _____ **ON/OFF**

Indicates the fuel pump status, reads ON when the ECM senses a running fuel pump.

FUEL PUMP CTRLRange: _____ **LOW/HIGH**

Displays the fuel pump control relay status, which indicates if the fuel pump is operating at HIGH or LOW capacity. Status is determined by intake manifold pressure and engine RPM.

FUEL PUMP RELAY**PUMP RELAY**Range: _____ **ON/OFF**

Indicates the current state of the fuel pump relay.

FUEL REF VOL (V)Range: _____ **0.0 to 5.0 V**

Indicates the status of the reference supply voltage for the fuel level sensor. It displays the input voltage to monitor and correct the supply voltage for the fuel level sensor.

FUEL STATUS**FUEL SYS**Range: _____ **CL/CL FLT/OL/OL DRV/OL FLT**

Indicates whether the vehicle is operating in open or closed loop, reads as follows:

- CL—Normal closed loop
- CL FLT—One O2S is not switching and the PCM is using the other one for feedback
- OL—Normal open loop
- OL DRV—Open loop because of driver action or other special circumstances
- OL FLT—Open loop with O2S problem or primary side coil failure

FUEL SYS1**FUEL SYS2****FUELSYS1****FUELSYS2**Range: _____ **OL/CL or OPEN/CLSD**

Indicates the operating status of fuel banks 1 and 2, read as follows:

- OL or OPEN for open loop
- CL or CLSD for closed loop

When a fuel bank status is OL or OPEN, the ECM ignores the main O2S signal. When a fuel bank status is CL or CLSD, the ECM uses main O2S feedback to make corrections to fuel injection duration. With the engine fully warm and running at idle, these parameters should indicate closed loop.

At 2500 RPM with no load, these parameters should also indicate closed loop. Deceleration could cause these parameters to indicate open loop during fuel cutoff. Some vehicles display only FUEL SYS1, while others display the status of both fuel banks.

FUEL SYS #1**FUEL SYS #2**Range: _____ **UNUSED,OL,CL,OL-DRV,OL-FLT,CL-FLT**

Indicates the fuel system status (#1 = bank 1, #2 = bank 2). Reading should be CL with the engine warmed up and running at idle. Interpret readings as follows:

- UNUSED: This parameter is not used on this engine

- OL (Open Loop): Has not yet satisfied conditions to go closed loop
- CL (Closed Loop): Using heated oxygen sensor as feedback for fuel control
- OL-DRV: Open loop due to driving conditions (fuel enrichment)
- OL-FLT: Open loop due to detected system fault
- CL-FLT: Closed loop but heated oxygen sensor, which used for fuel control malfunctioning

FUEL SYS MON

Range: _____ **NOT AVAILABLE/AVAILABLE**

Indicates the fuel system monitor.

FUEL TANK CAP(L)

Range: _____ **0 to 34 gallons or 0 to 128 liters**

Indicates the capacity of the fuel tank in liters or in gallons.

FUEL TEMP (°)

Range: _____ **-30 to 224°C or -22 to 435°F**

Indicates the ECM calculated fuel temperature within the intake manifold fuel rail. The ECM uses this parameter to fine-tune engine management.

FUEL VOLATI

Range: _____ **LO/HI**

Indicates the rate that the fuel can vaporize in the cylinder as calculated by the control module. HI displays when calculated fuel volatility is high. LO displays when the fuel volatility is low.

FUEL(PSI)

Range: _____ **35 to 120 psi**

Indicates the fuel pressure.

FUEL_GAUGE

Range: _____ **ON/OFF**

Indicates the fuel gauge indicator control.

FUEL_LEVEL(%)

Range: _____ **0 to 100%**

Indicates the fuel level in percentage.

FUEL_mon_ready

Range: _____ **YES/NO**

Indicates the fuel monitor has successfully completed.

FuelLvlInp(%)

Range: _____ **0 to 100%**

Indicates the fuel level in percentage.

FuelLvlInp(V)

Range: _____ **0.0 to 5.0 V**

Indicates the fuel level in voltage.

FuelPumpA

Range: _____ **ON/OFF**

Indicates the actual state of the PCM commanded fuel pump output.

FuelPumpA should read the same as the fuel pump monitor and fuel pump command output readings (all three should be ON or OFF at the same time).

FUELPW
FUELPW(mS)
 Range: _____ **0.0 to 99.9 mS**

Indicates the current commanded pulse width of the fuel injectors.

FUELPW1 (mS)
FUELPW2 (mS)
 Range: _____ **0 to 99.9 mS**

Indicates the current commanded pulse width of the injectors affected by O2S1 and O2S2. The displayed value is the pulse width that was commanded at the time of the last update.

On some vehicles, updating may occur only when a position indicator pulse (PIP) signal is being received, and the last updated value is retained after the PIP signal stops. In these cases, a value greater than zero may display during KOEO.

FuelTankPrs(V)
 Range: _____ **0.0 to 5.0 V**

Indicates signal voltage from the fuel tank pressure sensor. The EVAP monitor requires input from this sensor.

With the gas cap removed, signal voltage should be between 2.4 and 2.8 V. During the evaporative emissions test, expect voltage to decrease while the PCM applies vacuum to the fuel tank.

GEAR
 Range: _____ **actual**

Indicates the gear commanded by the module.

GEAR POSITION
 Range: _____ **variable**

Indicates the estimated gear position, calculated from both the "Main shaft speed sensor" and the "countershaft speed sensor".

GEN L TERMINAL
 Range: _____ **ON/OFF**

Indicates the state of the generator "L" terminal and reads as follows:

- ON under normal operating conditions
- OFF if the PCM detects incorrect voltage in the L terminal circuit

GEN LIGHT
 Range: _____ **ON/OFF**

Indicates the generator warning light status.

GEN OUT(V)
 Range: _____ **0.0 to 16.0 V**

Indicates the generator output voltage.

GEN. FIELD
 Range: _____ **ON/OFF**

Indicates the status of the generator field, reads ON when the system is charging.

GEN(%)
 Range: _____ **0 to 100%**

Indicates the generator field current control duty signal.

GEN_FAULT		
Range:	_____	YES/NO
Indicates if generator output fault is present. Reads YES if there is a charging problem.		
GEN_MON		
Range:	_____	ON/OFF
Indicates the generator monitor status.		
GENERATOR (%)		
Range:	_____	0 to 100%
Indicates the level of charge that the PCM is requesting as a percentage.		
GENFDC%		
Range:	_____	0 to 100%
Indicates the generator field duty cycle.		
GENVDS(V)		
Range:	_____	actual
Indicates the generator voltage desired.		
HAC PRS ZONE		
Range:	_____	ON/OFF
Indicates the high air charging pressure zone signal.		
HEADLIGHT SW		
Range:	_____	ON/OFF
Indicates the headlamp switch.		
HFC		
Range:	_____	ON/OFF
Indicates the fan control high speed status.		
HFC_FAULT		
Range:	_____	YES/NO
Indicates the fan control high speed fault status.		
HI A/C PRESS		
Range:	_____	YES/NO
Indicates A/C system pressure and reads YES when the pressure is high.		
HI PS PRESS		
HI PS PRESSURE		
P/S OIL PRESSURE SWITCH		
P/S PRESS SW		
PSP_SW		
PSP SWT		
PSP SWITCH		
Range:	_____	ON/OFF
Indicates the power steering pressure (PSP) switch status. Reads OFF when the steering wheel directs the wheels straight ahead, and reads ON when the steering wheel is turned or held turned in either direction. Turning the steering wheel builds pressure in the system.		

HIGH ALTITUDE

Range: _____ **YES/NO**

Indicates whether the vehicle is operating at high altitude, it reads YES when the ECM is controlling the engine for high altitude operation with low barometric pressure.

On some fuel-injected vehicles, the ECM compares the throttle position, mass airflow, and RPM readings to determine engine load. If the throttle is open more than expected for a given load, the ECM assumes it is operating at high altitude and adjusts fuel metering accordingly. Reads YES during high altitude operation.

HIGH BATTERY

Range: _____ **YES/NO**

Indicates the vehicle battery state, reads NO under normal conditions and YES when battery voltage is higher than specifications.

On most vehicles, a high battery voltage condition causes the ECM to disable the output solenoids to protect the ECM from high current.

HO2 SNSR-1 (mV)**HO2 SNSR-2 (mV)**

Range: _____ **0 to 1000 mV**

Indicates heated oxygen sensor (HO2S) output as millivolts. Sensor 1 is upstream (closest to the engine) and HO2S 2 is downstream (after the converter).

Sensor 1 voltage should fluctuate constantly from about 50 mV (lean exhaust) to 800 mV (rich exhaust) during closed loop operation. Sensor 2 voltage fluctuates slowly over a longer period of time due to the oxygen storage capability of an efficiently operating catalyst. If the voltage fluctuates rapidly on a hot catalyst, low catalyst efficiency may be the cause.

HO2S (mA)**HO2S S1 (mA)**

Range: _____ **-8.89 to 8.89 mA**

Indicates heated oxygen sensor (HO2S) output as milliamperes:

- Negative value = lean
- around 0 = ideal
- Positive value = rich

Sensor 1 (S1) is upstream, closest to the engine.

HO2S (AF) B1 S1 HEATER**HO2S (AF) B2 S1 HEATER****HO2S S-1 HEATER****HO2S B1 S2 HEATER****HO2S B2 S2 HEATER**

Range: _____ **ON/OFF**

Indicates the HO2S heater circuit status, it turns off if the battery voltage is above 16 volts. Reads ON when the heater is on, usually at idle with a cold exhaust. Cylinder bank 1 (B1) contains cylinder #1. Sensor 1 (S1) is upstream, closest to the engine.

HO2S 1 HEATER**HO2S 2 HEATER****HO2S 3 HEATER**

Range: _____ **ON/OFF**

Indicates the PCM command status to the HO2S 1, HO2S 2, and HO2S 3 heater circuits.

HO2S B1 H CUR
 HO2S B2 H CUR
 HO2S B1 HEATER CURRENT (mA)
 HO2S B2 HEATER CURRENT (mA)
 HO2S B1 S2 HEATER CURRENT (mA)
 HO2S B2 S2 HEATER CURRENT (mA)
 HO2S B1 S2 H CUR
 HO2S B2 S2 H CUR
 HO2S B2 S2 C (A)
 HO2S S2 H C (A)
 HO2S S2 HEATER CURRENT (mA)
 HO2S S2 HEATER
 HO2S S2 HTR

Range: _____ not available

Indicates the current applied by the ECM to the HO2S heater as amperes or milliamperes.

HO2S HEATED OXYGEN SENSOR (A/F)

Range: _____ 13.9 to 15.5

Indicates the air/fuel ratio (A/F) as determined by HO2S feedback signals.

HO2S B1 S1 (V)
 HO2S B2 S1 (V)
 HO2S B1 S2 (V)
 HO2S B2 S2 (V)
 HO2S S1 (V)
 HO2S S2 (V)
 HO2S S3 (V)

Range: _____ 0.0 to 1.4 V

Indicates heated oxygen sensor (HO2S) output as volts. Cylinder bank 1 (B1) contains cylinder #1. Sensor 1 (S1) is upstream (closest to the engine) and S2 is downstream (after the converter).

HO2S_mon_ready

Range: _____ YES/NO

Indicates the heated oxygen sensor (HO2S) monitor has successfully completed.

HO2S11 (mA)
 HO2S12 (mA)
 HO2S21 (mA)
 HO2S22 (mA)

Range: _____ -8.89 to 8.89 mA

Indicates the drive current supplied by the ECM to control the HO2S heater. The two digits after HO2S position the sensor:

- 11—Bank 1, Upstream
- 12—Bank 1, Downstream
- 21—Bank 2, Upstream
- 22—Bank 2, Downstream

HOT OPEN LOOP

Range: _____ YES/NO

Indicates whether the PCM has commanded open loop operation due to high engine temperature and reads YES only when in open loop.

HTD CAT MON CMPL

Range: _____ COMPLETE/INCOMPLETE

Indicates the heated catalyst monitor.

HTD CAT MON ENA

Range: _____ UNABLE/ENABLE

Indicates the heated catalyst monitor.

HTR11**HTR12****HTR21****HTR22**

Range: _____ ON/OFF

Indicates the HO2S heater circuit status for:

- 11—Bank 1, Upstream
- 12—Bank 1, Downstream
- 21—Bank 2, Upstream
- 22—Bank 2, Downstream

HTR11Fault**HTR12Fault****HTR21Fault****HTR22Fault****HTR11_Fault****HTR12_Fault****HTR21_Fault****HTR22_Fault**

Range: _____ YES/NO

Indicates the HO2S heater circuit fault exists for:

- 11—Bank 1, Upstream
- 12—Bank 1, Downstream
- 21—Bank 2, Upstream
- 22—Bank 2, Downstream

HTRCM11(A)**HTRCM12(A)****HTRCM21(A)****HTRCM22(A)**

Range: _____ ON/OFF

Indicates the heater current monitor for the heated exhaust oxygen sensor:

- 11—Bank 1, Upstream
- 12—Bank 1, Downstream
- 21—Bank 2, Upstream
- 22—Bank 2, Downstream

I/P PULLY RPM**I/P PULLY SPD (rpm)**

Range: _____ 0 to engine max.

Indicates the engine speed computed from the turbine revolution sensor signal.

IAB CTRL SOLRange: _____ **ON/OFF**

Indicates the state of the intake air bypass control solenoid valve, it should be ON at idle and OFF at all other times.

IAB HI CTRL SOLRange: _____ **ON/OFF**

Indicates the state of the intake air bypass high control solenoid valve, it should only be ON during high RPM operation.

IAB LOW CTRL SOLRange: _____ **ON/OFF**

Indicates the state of the intake air bypass low control solenoid valve, it should only be ON during low RPM operation.

IAC (%)**ISC (%)****IAC/AAC (%)****IAC(%)**Range: _____ **0 to 100%**

Indicates the duty cycle of the pulse-width-modulated (PWM) signal being applied to the idle air control (IAC) valve.

As the duty ratio exceeds 50%, the valve shaft moves in to open the air bypass passage. At a duty ratio less than 50%, the shaft moves to close the air bypass passage.

IAC COM**IAC COMMAND (COUNTS)**Range: _____ **not available**

Indicates the PCM commanded status of the idle air control valve as a count.

IAC DIRECTION**IVSMDIR1****IVSMDIR2**Range: _____ **FWD/REV**

Indicates the direction the ECM is commanding the idle air control (IAC) motor to move:

- FWD to reduce idle airflow
- REV to increase idle airflow

IAC STEPS**IAC/AAC STEPS****IDLE AIR CONTRL****ISC STEP****IVSMSTP (DEC)****MOTOR POS STEPS**Range: _____ **0 to 125 or 0 to 255**

Indicates the position of the idle air control (IAC) valve as a step count.

Stepper-motor IAC valves have either 125 or 255 positions, and readings vary from 0 to 125 or from 0 to 255:

- 0 means the motor has moved to its outer limit to close the IAC valve.
- 125 or 255 means the motor has moved to its inner limit to fully open the IAC valve.

IAC_FAULT**IACFault**

Range: _____ YES/NO

Indicates whether the PCM detects a fault in the idle air control (IAC) system, reads YES if a fault is present.

IACV(%)

Range: _____ 0 to 100%

Indicates the idle air control percentage.

IACV(mS)

Range: _____ not available

Indicates the idle air control in milliseconds.

IAR SOL

Range: _____ ON/OFF

Indicates the status of the intake air resonator solenoid valve. When the engine RPM is in the mid-range, the valve is turned ON to decrease air intake noise.

IASV

Range: _____ ON/OFF

Indicates the intake air shutter valve.

IAT

Range: _____ -40 to 399°F or -40 to 199°C

Indicates the intake air temperature.

IAT (V)**IAT 1****IAT 2****IAT SENSOR 1****IAT SENSOR 2****INTAKE AIR TEMPERATURE SENSOR(2)**

Range: _____ 0.0 to 5.0 V

Indicates the voltage signal from the IAT sensor, which is typically installed in the air cleaner. A 5 V reference signal is applied to the sensor, resistance decreases as temperature increases.

IAT_FAULT

Range: _____ YES/NO

Indicates the inlet air temperature status.

IATDC

Range: _____ -40 to 399°F or -40 to 199°C

Indicates the intake air temperature 2.

IATDC(V)

Range: _____ 0.0 to 5.0 V

Indicates the intake air temperature 2 in voltage.

IATLC(V)

Range: _____ 0.0 to 5.0 V

Indicates the Lysholm compressor intake air temperature signal voltage.

IDL A/V LEARNRange: _____ **YET/CMPLT**

Indicates the condition of Idle Air Volume Learning.

- YET: Idle Air Volume Learning has not been performed yet
- CMPLT: Idle Air Volume Learning has already been performed successfully

IDLE CTRL SOL (%)**IAC COM (%)**Range: _____ **-100 to 100%**

Indicates the drive percentage of the IAC solenoid valve.

IDLE LEARNRange: _____ **COMPLETED/NOT COMPLETED/NOT APPLICABLE**

Indicates whether the PCM completed the "idle learn" program.

IDLE STOP CTRLRange: _____ **YES/NO**

Indicates whether the ECM is operating in idle stop control mode.

IDLE TARGET TH (°)**MOTOR TH CMD (°)**Range: _____ **0 to 180°**

Indicates the PCM calculated target throttle valve position at idle in degrees.

IDLE UP SOLRange: _____ **ON/OFF**

Indicates the status of the idle up solenoid valve. The valve is turned ON when A/C SW is turned on, but it is controlled ON/OFF depending on the engine operating conditions.

IDLE UP VSVRange: _____ **ON/OFF**

Indicates the ECM command to the vacuum switching valve (VSV) is used to actuate the idle up valve. When ON, the idle up valve bleeds air into the intake manifold to raise RPM.

IDLINGRange: _____ **ON/OFF**

Indicates whether the engine is running at idle.

IG LEVEL**IG1 LEVEL**Range: _____ **HIGH/LOW**

Indicates the status of the IG1 voltage level.

IG MISFIRERange: _____ **actual count**

Indicates the misfire accumulated counter for 2VI method ignition systems.

IG T ADJ (V)Range: _____ **0.0 to 5.0 V**

Indicates the status of the ignition timing adjuster volume switch as volts. Ignition timing at idle is controlled by this volume switch.

IGDSBLRange: _____ **0/1**

Indicates the cessation of injection (B). Bit changes to 1 if injection of each cylinder ceases. Bit 0 doesn't always show cylinder #1.

IGN (V)**IGNITION (V)**Range: _____ **0.0 to 25.5 V**

Indicates the key-on system voltage.

IGN ACC SIGRange: _____ **ON/OFF**

Indicates the state of the ignition switch ACC input signal to the control module. This parameter displays ON when the ignition switch is in the ignition accessory position and OFF when the ignition switch is in any other position.

IGN ADJ TERM**OCT ADJ**Range: _____ **ON/OFF or CLSD/OPEN**

Indicates the state of the ignition timing adjustment terminal:

- ON or CLSD when shorted to ground, adjustment mode
- OFF or OPEN when open, normal mode

IGN ADVANCE(°)Range: _____ **Min.: -64 deg., Max.: 63.5 deg.**

Indicates the ignition timing advance for Number 1 cylinder. Typical readings range from 5 to 22° BTDC with the engine running at idle.

IGN ADVANCE (°)**IGN ADV(°)****IGN TIMING(°)****SPK ADV (°)****SPK ADV (°BTDC)****SPARK ADV (°)****SPARK ADVANCE****TIMING (°BTDC)****TOTAL ADV (°)**Range: _____ **-90 to 90°**

Indicates the amount of total spark advance or retard being commanded by the ECM as degrees. The value including base timing on most vehicles, On some vehicles, such as Chrysler Imports, the value does not including base timing.

IGN CYCLESRange: _____ **0 to 50**

Indicates the number of times the engine has been started since the last DTC set or codes were cleared.

IGN CYCLE DTCRange: _____ **YES/NO**

Indicates whether a DTC set on the current ignition cycle.

IGN EVENTS X**IGNITION**Range: _____ **see below**

Indicates the number of ignition events the ECM expects to occur during the next 1000 crankshaft revolutions. The PCM uses this information to determine the misfire rate. Range varies by the number of cylinders:

- 0 to 2000 for a 4-cylinder engine
- 0 to 3000 for a 6-cylinder engine
- 0 to 4000 for a 8-cylinder engine

The "X" in "IGN EVENTS X" is a value from 1 to 8, depending on the cylinder being monitored.

IGN FUEL VTDRange: _____ **YES/NO**

Indicates whether a Vehicle Theft Deterrent (VTD) code is stored in memory.

IGNITIONRange: _____ **Min.: 0, Max.: 800**

Indicates ignition counter: 0 to 800.

IGNITION 1 (V)Range: _____ **0.0 to 25.5 V**

Indicates system voltage measured by the ECM at its ignition feed circuit. Ignition voltage is only present when the vehicle is running.

IGNITION SWRange: _____ **ON/OFF**

Indicates the status of the ignition switch:

- ON when the switch is on, the engine is running and not cranking
- OFF when the switch is in any position other than run

IGRTNE (V)Range: _____ **0.0 to 5.0 V**

Indicates the signal voltage on the IGRTNE circuit.

IGRTNI (V)Range: _____ **0.0 to 5.0 V**

Indicates the signal voltage on the IGRTNI circuit.

ILLUMINAT(%)Range: _____ **0 to 100%**

Indicates the dimming control command as a percentage.

IMA (V)Range: _____ **0.08 to 4.92 V**

Indicates the status of the idle mixture adjuster volts. This is a variable resistor that controls the idle mixture.

IMA OUTPUT (kw)Range: _____ **not available**

Indicates the Integrated Motor Assist (IMA) output current the ECM requests of the Motor Control Module (MCM) for assist or regeneration.

IMA REQUEST (kW)

Range: _____ not available

Indicates the target value which the ECM requests of the motor control module for assist or regeneration.

IMA STANDBY

Range: _____ YES/NO

Indicates the status of the Integrated Motor Assist (IMA) standby status. Reads NO if the IMA cannot assist the engine and reads YES at all other times.

IMA TORQUE

Range: _____ -15 to 15 kgfm or -147 to 147 N.m

Indicates the status of the Intergraded Motor Assist (IMA) motor torque.

IMMOBILIZER

Range: _____ BAN/RUN

Indicates the status of the immobilizer system:

- BAN, the immobilizer module prevents ECM from starting the engine.
- RUN, the immobilizer module allows ECM to start the engine.

IMRC

Range: _____ ON/OFF

Indicates the intake manifold runner control.

IMRC MON SW

Range: _____ ON/OFF

Indicates the intake manifold runner control monitor.

IMRC POS SENSOR**IMRC VP SENSOR (V)**

Range: _____ 0.0 to 5.0 V

Indicates the intake manifold runner control solenoid valve position sensor signal voltage.

IMRC SOL**IMRC SOL VLV**

Range: _____ ON/OFF

Indicates the status of the intake manifold runner control solenoid valve.

IMRC VLV CMD**IMT (IMRC) VLV CMD**

Range: _____ OPEN/CLOSE

Indicates the PCM command to the intake manifold runner control solenoid valve position switch. It should read CLOSE at low engine speed.

IMT (IMRC) VALVE SW**IMT (IMRC) VLV SWT****IMT VLV SW**

Range: _____ OPEN/CLOSE

Indicates the status of the intake manifold runner control solenoid valve position switch. It should read CLOSE at low engine speed.

IMTV

Range: _____ ON/OFF

Indicates the intake manifold tuning valve.

IMTV (%)	
Range: _____	0 to 100%
Indicates the PCM-command status for the intake manifold tuning valve. At 100% the valve should be fully open.	
IMTV(%)	
Range: _____	0 to 100%
Indicates the duty cycle of the intake manifold tuning valve.	
IMTV_FAULT	
Range: _____	YES/NO
Indicates an intake manifold tuning valve fault.	
INDDRNG (ON/OFF)	
Range: _____	ON/OFF
Indicates the "Drive" position indicator output.	
INDLRNG (ON/OFF)	
Range: _____	ON/OFF
Indicates the "Low" position indicator output.	
INDNRNG (ON/OFF)	
Range: _____	ON/OFF
Indicates the "Neutral" position indicator output.	
INDPRNG (ON/OFF)	
Range: _____	ON/OFF
Indicates the "Park" position indicator output.	
INDRRNG (ON/OFF)	
Range: _____	ON/OFF
Indicates the "Reverse" position indicator output.	
INGEAR	
Range: _____	actual
Indicates if the vehicle is in gear.	
INH SW3M (ON/OFF)	
Range: _____	ON/OFF
Indicates the PNP switch 3 status.	
INH SW4 (ON/OFF)	
Range: _____	ON/OFF
Indicates the PNP switch 4 status.	
INH SW3 (ON/OFF)	
Range: _____	ON/OFF
Indicates the PNP switch 3 status.	
INH SW2 (ON/OFF)	
Range: _____	ON/OFF
Indicates the PNP switch 2 status.	
INH SW1 (ON/OFF)	
Range: _____	ON/OFF
Indicates the PNP switch 1 status.	

INI IAT TMP**INI COOL TEMP****INI COOL TMP**

Range: _____ **-40°F to 249°F or -40°C to 120°C**

Indicates the initial intake air temperature on engine first start. Should be close to ambient air temperature.

INJ (mS)**INJ PW (mS)****INJ #1 (mS)****INJ #1 PW (mS)****INJ #2 (mS)****INJ #2 PW (mS)****INJ B1 (mS)****INJ B2 (mS)****INJ L(mS)****INJ L(mS)****INJECTOR (mS)****INJ PULSE-B1(mS)****INJ PULSE-B2(mS)****INJ #x (mS)**

Range: _____ **0 to 65.3 mS**

Indicates fuel-injection pulse width in milliseconds. The pulse width is the length of time that the ECM commands the fuel injectors to turn on.

A high pulse width indicates more on-time and a richer mixture. A low pulse width indicates less on-time and a leaner mixture. There are no definite specifications for injector pulse width, but the reading should change as engine speed and load change. Typical readings at idle are 2.2 to 3.0 mS, and 2.1 to 2.9 mS at 3000 rpm.

The "x" in INJ #x is a variable from 1 to 8, depending on the cylinder.

INJ PW B1(mS)**INJ PW B2(mS)**

Range: _____ **0 to 1000 mS**

Indicates the amount of time the PCM commands each injector ON during an engine cycle in milliseconds. A longer injector pulse width causes more fuel to be delivered. The injector pulse width increases as the engine load increases.

- B1 represents cylinder bank 1 (cylinders 1, 3, 5, and 7)
- B2 represents cylinder bank 2 (cylinders 2, 4, 6, and 8)

INJ1Fault
INJ2Fault
INJ3Fault
INJ4Fault
INJ5Fault
INJ6Fault
INJ1_Fault
INJ2_Fault
INJ3_Fault
INJ4_Fault
INJ5_Fault
INJ6_Fault
 Range: _____ **YES/NO**

Indicates whether the PCM has detected an injector circuit fault, it reads YES when the PCM detected a fault.

INJECTOR MODE
 Range: _____ **ON/OFF**

Indicates the status of the injector mode control operation. It reads ON right after the ignition switch is turned on under cold circumstances.

INLET AIR TEMP
 Range: _____ **HOT/COOL**

Indicates the state of the intake air temperature switch:

- HOT when air temperature is approximately 60°F (15°C) or more
- COOL when air temperature is about 40°F (4°C) or less

INPUT RPM
 Range: _____ **0 to 8192 rpm**

Indicates the rotational speed of the input shaft.

INT AIR CTL VSV
INTAKE AIR VSV
 Range: _____ **ON/OFF**

Indicates the ECM command to the vacuum switching valve (VSV) that actuates the second turbocharger intake air control valve. When ON, the VSV should be activated and the control valve should be open.

INT/V SOL B1 (%)
INT/V SOL B2 (%)
 Range: _____ **0 to 99%**

Indicates the control value of the intake valve timing control solenoid valve. It should read:

- 0% to 2% at idle.
- 0% to 80% when revving the engine up to 2000 RPM quickly.

INT/V SOL-B1
INT/V SOL-B2
 Range: _____ **ON/OFF**

Indicates the state of the intake valve timing control solenoid.

INT/V TIM B1 (°)**INT/V TIM B2 (°)**

Range: _____ **-127 to 128°**

Indicates the intake camshaft advance angle. It should read:

- -5° to 5° at idle.
- 0° to 45° when revving the engine up to 2000 RPM quickly.

INTAKE AIR

Range: _____ **Min.: -40°F, Max.: 258°F or Min.: -40°C, Max.: 140°C**

Indicates the intake air temperature: equivalent to ambient air temperature.

- If value -40°C (-40°F): sensor circuit open
- If value 140°C (284°F): sensor circuit shorted

INTAKE CNTRL

Range: _____ **0 to 255**

Indicates the position of the intake tuning valve stepper motor inside the intake manifold runner as a step count. The greater the count, the wider the intake tuning valve opening.

INTAKE CTL VSV1**INTAKE CTL VSV2****INTAKE VSV**

Range: _____ **ON/OFF**

Indicates the status of the vacuum switching valve (VSV) that actuates the intake manifold runner control valve. Reads ON when the VSV is activated to open the valve.

INTAKE CTRL SOL

Range: _____ **ON/OFF**

Indicates the status of the intake air duct runner control solenoid valve. Reads ON when the solenoid is activated, this reduces the sound of the intake air.

INTEGRATR

Range: _____ **0 to 255**

Indicates whether the ECM is commanding a rich or a lean mixture as part of the short-term fuel metering correction strategy.

The integrator number can range from 0 to 255. An integrator number higher than 128 indicates the ECM is commanding a short-term rich mixture. An integrator number lower than 128 indicates that the ECM is commanding a short-term lean mixture.

Compare integrator numbers to injector on-time. A number above 128 indicates increased on-time. A number below 128 indicates decreased on-time. Integrator corrections operate only in closed loop. In open loop, the integrator number goes to a fixed value, usually 128.

The block learn multiplier (BLM) is a long-term fuel metering correction factor. BLM is derived from the integrator correction. Block learn and integrator indicate the same directions of fuel metering correction. High numbers indicate rich mixtures; low numbers indicate lean mixtures. Refer to "BLM" on page 353 for more information.

ISOLT1

Range: _____ **0.0 A / 0.7 A**

Indicates the torque converter clutch solenoid valve output current.

ISOLT2

Range: _____ **0.8 A / 0.0 A**

Indicates the pressure control solenoid valve A (line pressure solenoid valve) output current.

ISOLT3Range: _____ **0.8 to 0.0 A**

Indicates pressure control solenoid valve B (secondary pressure solenoid valve) output current.

ISTPIMRange: _____ **not available**

Indicates whether the ECM is in the IACV step motor inspection mode.

IVSRange: _____ **IDLE/OFF IDLE**

Indicates the idle validation switch status.

IVSRange: _____ **YES/NO**

Indicates the idle validation switch (IVS) state, which verifies (reads YES) that the accelerator pedal (AP) is in the idle position on diesel powertrain control systems. The IVS provides a check on the AP sensor. The MIL lights if the IVS signal does not match the AP sensor signal. A faulty IVS or AP sensor allows the engine to run at low idle speed only.

IXREF**IXREF/QXREF**Range: _____ **not available**

Indicates the status of the learned ICMD at idle.

KAMFUSERange: _____ **FAULT/OK**

Indicates the status of the keep alive memory power.

KNOCKRange: _____ **YES/NO**

Indicates whether the ECM is actively making adjustments to compensate for spark knock. This value is based on knock sensor (KS) signal, it reads:

- YES if the sensor indicates knock
- NO if the sensor does not indicates engine knock

KNOCK ADVANCE (°)**KNOCK CTRL**Range: _____ **not available**

Indicates the corrected spark advance angle the ECM is applying to compensate for knock.

KNOCK CRRT(°)Range: _____ **Min: -64 CA, Max.: 1,984 CA**

Indicates the correction learning value based on the knock sensor signal. 3 to 28° Crank Angle: Driving at 44 mph (70 km/h).

KNOCK CRRT VALRange: _____ **-64 CA to 1,984 CA**

Indicates the correction learning value of knocking. When driving 44 mph, a reading of 0 to 22 CA is considered normal.

KNOCK CTRL EGRRange: _____ **not available**

Indicates the ignition timing correction the ECM is applying to compensate for engine knock caused by the EGR system being active.

KNOCK FB(°)Range: _____ **Min:-64 CA, Max.: 1,984 CA**

Indicates the feedback value of knocking. -25 to 0° Crank Angle: Driving at 44 mph (70 kph).

KNOCK FB VALRange: _____ **-64 CA to 1,984 CA**

Indicates the correction learning value of knocking. When driving 44 mph, a reading of -22 to 0 CA is considered normal.

KNOCK RET (°)**KNOCK RETARD (°)****KNOCK RETARD CYL 1 (°)****KNOCK RETARD CYL 2 (°)****KNOCK RETARD CYL 3 (°)****KNOCK RETARD CYL 4 (°)****KNOCKR(°)**Range: _____ **0 to 90°**

Indicates the additional spark retard angle the ECM is applying to compensate for knock.

The value does not indicate that timing is retarded after top dead center. It indicates the amount of advance that has been taken away.

KNOCK SENSOR**KNOCK SNSR 1 (V)****KNOCK SNSR 2 (V)**Range: _____ **0.0 to 5.0 V**

Indicates the voltage signal of the knock sensor (KS). The normal range is 0.8 to 1.0 V, higher voltage indicates increased knock.

There are 2 types of KS currently being used: broadband sensors and flat sensors. Broadband sensors have a single wire and the flat sensors have two wires. Broadband and flat sensor signals are processed differently by the PCM. Both systems constantly monitor the KS system for a signal that is not present or falls within the noise channel range.

KSOKRange: _____ **OK/NG**

Indicates the status of the knock sensor circuit, it reads OK during normal operation and NG if a fault is detected.

L SWITCHRange: _____ **ON/OFF**

Indicates the transmission Low range switch.

LCHSTSRange: _____ **ON/OFF**

Indicates the status of the latched starter switch signal, it reads ON when STS is turned on.

LDP_EVAPCP(A)Range: _____ **not available**

Indicates the EVAP control system incorrect purge flow detection valve status.

LDP_IDL(A)Range: _____ **not available**

Indicates the EVAP system leak detection idle current.

LDP_MON(A)		
Range:	_____	not available
Indicates the EVAP system leak detection pump monitoring current.		
LDP_REF(A)		
Range:	_____	not available
Indicates the EVAP system leak detection pump reference current.		
LDP_SLDV(A)		
Range:	_____	not available
Indicates the EVAP control system small leak detection valve.		
LDP_VSLD(V)		
Range:	_____	not available
Indicates the EVAP control system very small leak detection valve.		
LFC		
Range:	_____	ON/OFF
Indicates the status of the electrically driven fan.		
LFC_FAULT		
Range:	_____	YES/NO
Indicates a fan control low speed fault.		
LFTRIM 1 (%)		
LFTRIM 2 (%)		
Range:	_____	-35 to 35%
Indicates whether the ECM is commanding a rich or a lean mixture as part of the long-term fuel metering correction strategy.		
Similar to short-term fuel trim (SFTRIM), the LF TRIM number can range from -35% to +35%, with 000% as the midpoint. A number above zero percent indicates the PCM has commanded a long-term rich mixture correction. A number below zero percent indicates the PCM is commanding a lean mixture.		
The LF TRIM number follows the short-term fuel (ST FUEL) number and makes long-term corrections to the fuel-metering in response to a pattern or trend of short-term fuel changes.		
Compare LF TRIM numbers to injector on-time. Numbers above zero percent indicate increased on-time. Numbers below zero percent indicate decreased on-time. LF TRIM corrections operate only in closed loop. In open loop, the number goes to a fixed value.		
LG FL IDLE (mS)		
Range:	_____	not available
Indicates the long term fuel correction being applied at idle.		
LIFT SWITCH		
Range:	_____	ON/OFF
Indicates the status of the lift switch, it reads ON when the lift switch is turned on.		
LINE PRES(%)		
Range:	_____	0 to 100%
Indicates the line pressure solenoid status in percentage.		
LINE PRESS(A)		
Range:	_____	not available
Indicates the line pressure solenoid status.		

LO SPEED CUTRange: _____ **NON/CUT**

Indicates the vehicle cruise condition.

- NON—Vehicle speed is maintained at the ASCD set speed
- CUT—Vehicle speed decreased to excessively low compared with the ASCD set speed, and ASCD operation is cut off

LOAD (%)Range: _____ **0 to 100%**

Indicates the relative engine load. The ECM calculates this value by dividing the actual manifold airflow volume by the maximum possible manifold airflow volume. A high number indicates a heavy load, a low number a lighter load.

LONGFT1(%)Range: _____ **0 to 100%**

Indicates long term fuel trim 1 in percentage.

LONGFT2(%)Range: _____ **0 to 100%**

Indicates long term fuel trim 2 in percentage.

LOOP**LOOP STATUS (L)****LOOP STATUS (R)****O2S FB COND****OPEN/CLSD LOOP**Range: _____ **OPEN/CLSD**

Indicates whether the engine is operating in open or closed loop, it should read:

- OPEN during warm-up, open loop
- CLSD during normal operating temperature operation, closed loop

Some vehicles display separate parameters for the left and right banks.

Some failure conditions (many associated with trouble codes) cause the ECM to return to open-loop operation. Some vehicles may normally return to open-loop operation at idle. This is usually because the O2S cools off at idle, and the ECM returns to open loop. You should be able to restore closed-loop operation by accelerating off idle to warm the sensor.

LOW BATTERYRange: _____ **YES/NO**

Indicates the vehicle battery state, reads NO under normal conditions and YES when battery voltage is below specifications.

LOW CLNT LEVELRange: _____ **YES/NO**

Indicates whether the low coolant level switch has been activated, it reads:

- YES if the coolant level is low
- NO at all other times

LOW FUEL INDIRange: _____ **ON/OFF**

Indicates the status of the low fuel indicator lamp on the instrument cluster. It should read ON when the low fuel indicator lamp is on. The low fuel lamp blinks if a malfunction is detected in the fuel tank pressure or temperature sensor circuits.

LOW OIL LAMPRange: _____ **ON/OFF**

Indicates the status of the engine oil pressure lamp. It should read ON when the engine oil pressure indicator lamp is on.

LOW OIL LEVELRange: _____ **YES/NO**

Indicates the status of the engine oil level is low, it reads:

- YES when the PCM detects a low engine oil level
- NO under normal operation

LOW OIL PRESSRange: _____ **YES/NO**

Indicates the status of the engine oil pressure sensor, it reads:

- YES when oil pressure is low
- NO under normal operation

LOW RPM RANGERange: _____ **ON/OFF**

Indicates whether the engine is operating in the low RPM range. It reads ON during low RPM operation, and OFF at all other times.

LOW SELECTEDRange: _____ **YES/NO**

Indicates the transmission L range switch.

LT ADP B2S2 (ms)Range: _____ **not available**

Indicates the long-term ADP values of the rear O2S for compensating fuel.

LT ALPHA (%)**LT ALPHA B2 (%)****LT TRIM-1 (%)****LT TRIM-2 (%)****LT TRIM B1 (%)****LT TRIM B2 (%)**Range: _____ **variable**

Indicates whether the ECM is commanding a rich or a lean mixture as part of the long-term fuel metering correction strategy. The value changes in response to changing patterns of the short-term fuel trim corrections.

Long-term fuel trim ranges from -100% to +100%, -25% to +25%, or 0 to 200% depending on the vehicle. Depending on which scale is used, zero or 100 percent serves as the midpoint. A number above the midpoint indicates the PCM is commanding a long-term rich mixture correction. A number the midpoint indicates the PCM is commanding a lean mixture.

Long-term fuel trim numbers follow the short-term fuel trim numbers to make long-term fuel metering corrections, in response to a pattern of short term corrections.

Compare Long-term fuel trim values to injector on-time. Numbers above the midpoint indicate increased on-time, while numbers below the midpoint indicate decreased on-time. Fuel trim corrections operate only in closed loop. In open loop they revert to a fixed value.

LT FUEL TRIM (COUNTS)
LT FUEL TRIM B1 (COUNTS)
LT FUEL TRIM B2 (COUNTS)

Range: _____ **0 to 255**

Indicates the status of the long-term fuel trim as a step count. This is derived from the short term fuel value and it is used for long term correction of fuel delivery:

- A value below 128 counts or 0% indicates O2S feedback shows a rich condition and the vehicle control module (VCM) is commanding a lean mixture in response.
- A value above 128 counts or 0% indicates O2S feedback shows a lean condition and the VCM is commanding a rich mixture in response.

Numbers 1 and 2 refer to the individual cylinder banks.

LT TRM AVG1 (%)
LT TRM AVG2 (%)

Range: _____ **0 to 100%**

Indicates the average of all long term fuel trim cells as percentage. The short term fuel trim cells are rated, for the amount of which they are used.

For example, an idle cell is rated higher than a wide open cell. If a fueling malfunction occurs in the idle cell and the wide open cell, the average would be more affected by the idle cell than the wide open cell.

A low value indicates that the fuel system is rich and fuel delivery is being reduced. A high value indicates that a lean condition exists and the PCM compensates by adding fuel. When the average of the cells reach a predetermined high or low, a fuel trim DTC sets.

LUSEL SOL MON

Range: _____ **ON/OFF**

Indicates the status of the torque converter lock-up.

- ON when lock-up
- OFF when no lock-up

LUSEL SOL OUT

Range: _____ **ON/OFF**

Indicates the status of the lock-up select solenoid valve.

- ON when selector lever is in "P" and "N" positions
- When OFF, wait for at least 5 seconds with the selector lever in "R", "D", "S", and "L" positions

M SHAFT SPD (RPM)
MAINSHAFT SPD (RPM)

Range: _____ **ON/OFF**

Indicates the state of the transmission mainshaft speed sensor signal. It should read ON whenever the mainshaft is turning.

M/T SHIFT LOCK

Range: _____ **ON/OFF**

Indicates the state of the M/T shift lock relay. It indicates ON when the ECM commands the shift lock relay to turn on.

M_DPFE

Range: _____ **actual**

Indicates the EGR sensor input at the time of a misfire.

M_ENG
Range: _____ actual

Indicates the engine RPM at the time of a misfire.

M_IAT
Range: _____ actual

Indicates the intake air temperature (IAT) at the time of a misfire.

M_LOAD
Range: _____ actual

Indicates the engine load at the time of a misfire.

M_PNP
Range: _____ PARK NEUTRAL

Indicates the park/neutral position (PNP) at the time of a misfire.

M_RUN
Range: _____ actual

Indicates the engine running time at the time of a misfire.

M_SOAK
Range: _____ actual

Indicates the engine-off soak time in minutes prior to a misfire.

M_TP
Range: _____ actual

Indicates the throttle position at the time of a misfire.

M_TRIP
Range: _____ actual

Indicates the number of trips since the time of a misfire.

M_VSS
Range: _____ actual

Indicates the vehicle speed at the time of a misfire.

MAF (gm/Sec)

MAF (g/s)
Range: _____ 0 to 665 g/s

Indicates mass airflow (MAF), which is the amount of air entering the engine, expressed as grams-per-second. The value is determined by the MAF sensor signal.

- If value 2.7 to 3.7 g/s: Idling
- If value 8.8 to 9.8 g/s: 2,000 rpm
- If value approximately 0.0 g/s: Mass air flow meter power source circuit open; VG circuit open or short
- If value 160.0 g/s or more: E2G circuit open

MAF (Hz)
Range: _____ 0 to 31,999 Hz

Indicates mass airflow (MAF), which is the amount of air entering the engine, expressed as hertz. The value is determined by the current needed to keep the hot wires of the MAF sensor at a constant temperature.

MAF (V)**MAF(V)**Range: _____ **0 to 5.00 V**

Indicates mass airflow (MAF), which is the amount of air entering the engine, expressed as voltage. This is the MAF sensor signal, readings should increase along with throttle opening.

MAF PERF TSTRange: _____ **FAIL/PASS**

Indicates mass airflow performance.

MAF_FAULTRange: _____ **YES/NO**

Indicates a mass airflow fault.

MAIN RELAYRange: _____ **ON/OFF**

Indicates the status of the main relay, which supplies power to the fuel tank internal solenoid valve and fuel pressure regulator shut-off solenoid valve. Reads ON when energized.

MAIN RELAY (FP)Range: _____ **ON/OFF**

Indicates the status of the main relay for the fuel pump, reads ON when energized. The main relay contains two relays, this is the second of the 2 relays.

MAINRLYRange: _____ **ON/OFF**

Indicates the PCM control relay.

MALFUNCTION INDICATOR LAMP**MIL****MIL STATUS**Range: _____ **ON/OFF**

Indicates the status of the malfunction indicator lamp (MIL).

MAN VAC (kPa)(inHg)Range: _____ **0 to 205 kPa or 0 to 60.7 inHg**

Indicates the ECM calculated manifold vacuum based on manifold absolute pressure (MAP) sensor signal voltages. The reading should be:

- Close to 0 (inHg or kPa) with the engine off and the manifold close to atmospheric pressure at sea level.
- High on an engine running at idle.

The ECM compares the barometric (BARO) pressure reading taken from the MAP sensor before startup to the MAP voltage while the engine is running to determine intake manifold vacuum.

MANIFOLD ABSOLUTE PRESSURE SENSORRange: _____ **variable**

Indicates the manifold absolute pressure (MAP) sensor that detects the intake manifold pressure and converts it into voltage and sends it to the ECM. The MAP sensor data is used along with other sensor inputs to determine basic Fuel-injection timing.

MAP

MAP SENSOR

Range: _____ **0 to 255 kPa, 0 to 75.3 inHg or 0 to 1913 mmHG**

Indicates the ECM calculated a manifold absolute pressure (MAP), which is based on the MAP sensor signal voltage. When MAP is displayed in kPa, the reading should be approximately 100 to 102 with the engine off and manifold pressure is close to atmospheric pressure at sea level. When the engine is running and manifold vacuum is high, the kPa reading drops. On a turbocharged engine, the reading rises above 100 as boost is applied.

When MAP is displayed as inches of mercury (inHg or "Hg), the reading should be about 29.9 with the engine off and the manifold close to atmospheric pressure at sea level. When the engine is running with high manifold vacuum, the MAP reading in drops. On a turbocharged engine, the reading rises above 30 as boost is applied.

Table 18-5 MAP voltage to pressure relationship

Voltage	High							Low
MAP (kPa)	70	60	50	40	30	20	10	
MAP ("Hg)	21	18	15	12	9	6	3	
MAP (mmHG)	533	457	381	305	229	152	76	

Compare the MAP voltage and MAP pressure readings displayed on the scan tool. Pressure should be high when voltage is high, low when voltage is low. If the readings appear abnormal for the apparent engine load, the sensor signal to the ECM may be inaccurate or the ECM calculations may be incorrect for some reason.

MAP (V)

Range: _____ **0 to 5.12 V**

Indicates the MAP sensor signal voltage. Voltage varies with manifold pressure, it should be:

- Low when absolute pressure is low (high manifold vacuum).
- High when absolute pressure is high (low manifold vacuum).

MAP(Hz)

Range: _____ **see below**

Indicates the manifold absolute pressure (MAP) sensor outputs frequency signal, which is relative to intake manifold vacuum. The MAP sensor frequency increases as intake manifold vacuum decreases.

MAP(Hz) reads as follows:

- 80 Hz at 101.6 kPa (30 inHg) of manifold vacuum.
- 159 Hz at zero manifold vacuum.

The PCM uses the MAP signal to determine engine load and regulate the air-fuel ratio, ignition timing, and EGR flow and to compensate for altitude.

MAP SOL V

Range: _____ **ON/OFF**

Indicates the boost sensor solenoid valve status.

MAP/BARO SOL**MAP/BARO SOLENOID**Range: _____ **MAP/BARO**

Indicates the state of the MAP/BARO solenoid valve, which applies intake manifold vacuum or barometric (atmospheric) pressure to the sensing port of the absolute pressure sensor. Compare to the ABSOL PRES(V) absolute pressure voltage as follows:

- MAP displays if the ABSOL PRES(V) parameter shows MAP voltage.
- BARO displays if the ABSOL PRES(V) parameter shows BARO voltage.

MAP/BARO SOLRange: _____ **ON/OFF**

Indicates the state of the MAP/BARO solenoid status.

MAP/BARO("Hg)Range: _____ **see below**

Indicates the barometric pressure, which is calculated by the PCM based on the frequency of the barometric pressure (BP) sensor signal.

This parameter reads as follows:

- 30.1 inHg at sea level.
- 23 inHg at 7,000 feet.

MAP/BARO(V)Range: _____ **2.6 to 4.6 V**

Indicates the barometric pressure as voltage and should read as follows:

- 4.6 V at sea level.
- 2.6 V at an elevation of 10,000 feet.

MAP_FAULTRange: _____ **YES/NO**

Indicates the manifold absolute pressure sensor status.

MAT (°C)Range: _____ **-40 to 199°C or -40 to 389°F**

Indicates the ECM calculated manifold air temperature (MAT), the temperature of the intake air charge. A thermistor-type temperature sensor installed in the intake manifold is usually used to measure intake air temperature, the ECM converts MAT sensor voltage to an air temperature reading.

The MAT reading should be close to ambient air temperature on a cold engine, and should rise steadily as the engine warms. High-temperature MAT readings may differ greatly from vehicle to vehicle because of the underhood temperature variations and hot-soak conditions.

MAX ENG SPD (RPM)Range: _____ **0 to engine max.**

Indicates the maximum highest engine speed the engine has ever achieved.

MC DWL (°)Range: _____ **0 to 60°**

Indicates the duty cycle, or on-time, of the mixture control (MC) solenoid on a carbureted engine. It usually is based on a 6-cylinder dwell scale of 0 to 60 degrees, expect:

- A low dwell reading when the ECM is commanding a rich mixture.
- A high dwell reading when the ECM is commanding a lean mixture.

On a 4-cylinder (90°) scale, the midpoint of the dwell range is 45°, which indicates a 50% duty cycle. On a 6-cylinder scale, the midpoint of the range is 30°, which indicates a 50% duty cycle.

MCM STANDBY

Range: _____ **OK/NG**

Indicates the MCM standby status and the status of motor ECM. When OK, the MOT ECM works to control assist and regenerative power of the IMA motor.

MFC

Range: _____ **ON/OFF**

Indicates the medium fan control status.

MFC_FAULT

Range: _____ **YES/NO**

Indicates a medium fan control fault.

MFCYLM**MISFIRED CYL**

Range: _____ **not available**

Indicates random (B) engine misfire information.

MFPINS

Range: _____ **not available**

Indicates engine misfires. This is the latched MFPLS signal low period when the ECM detects misfires. 1 LSB = 16 microseconds.

MFPLSRF**MFPLSR**

Range: _____ **LOW/HIGH**

Indicates the status of the front (F) or rear (R) misfire pulse. This is the misfire pulse signal from the 2VI unit to the ECM.

MFPMAX

Range: _____ **not available**

Indicates engine misfires. It displays the maximum data of MFPINS in microseconds.

MIL DIST

Range: _____ **actual distance**

Indicates how far the vehicle has traveled with the MIL turned on.

MIL ON RUN DIST

Range: _____ **Min.: 0 mile, Max.: 110,950 mile or Min.: 0 km, Max.: 65,535 km**

Indicates the distance the vehicle has been driven since the malfunction indicator lamp (MIL) was switched on by the PCM. The display reads 0 unless the MIL has been commanded on. Once activated, the accumulated kilometers or miles display. When the PCM memory is cleared, or if 40 warm-up cycles occur without the MIL setting conditions reoccurring, the display resets.

MIL ON RUN TIME

Range: _____ **0 to 65,535 sec**

Indicates the time lapse since the MIL was triggered by a DTC being set.

MIL ON RUN TIME (MIN)

Range: _____ **Min.: 0 minute, Max.: 65,535 minutes**

Indicates running time from MIL command ON, after DTC detected.

MIL REQ by DTCRange: _____ **YES/NO**

Indicates YES only when the MIL is requested as a result of an A or B type DTC. If the MIL is illuminated for another reason, such as transmission DTCs, NO will display. DTC types A and B are emissions related to DTCs that will update freeze frame/failure records. The difference between type A and type B are as follows:

- A type A DTC will illuminate the MIL when the diagnostic runs and fails.
- A type B DTC will illuminate the MIL on the second consecutive ignition cycle that the diagnostic runs and fails.

MILFaultRange: _____ **ON/OFF**

Indicates whether a fault has occurred in the MIL circuit.

MISFIRE**MISFire**Range: _____ **YES/NO**

Indicates the accumulated misfires for CSF method.

MISFIRE CMPLRange: _____ **COMPLETE/INCOMPLETE**

Indicates the misfire monitor.

MISFIRE CYCLESRange: _____ **0 to 100**

Indicates the number of engine cycles that were analyzed for misfire data. This is a count of the misfire tests during 200 crankshaft revolutions.

MISFIRE CYCLE (COUNTS)**MISS CYCLE**Range: _____ **0 to 2000**

Indicates the misfire cycle counter. This counts the number of TDC occurrences in each 1000 engine rotations. It returns to zero at 2000 counts with a 4-cylinder engine, and returns to zero at 3000 counts on a 6-cylinder engine.

MISFIRE CYL 1**MISFIRE CYL 2****MISFIRE CYL 3****MISFIRE CYL 4****MISFIRE CYL 5****MISFIRE CYL 6****MISFIRE CYL 7****MISFIRE CYL 8**Range: _____ **0 to 255**

Indicates the number of possible misfires detected on each cylinder during the last 200 cylinder firing events. These readings normally display some activity, but the activity should be fairly equal for all cylinders.

MISFIRE ENARange: _____ **UNABLE/ENABLE**

Indicates the misfire monitor.

MISFIRE LOAD(g/sec)Range: _____ **Min.: 0 g/rev, Max.: 3.98 g/rev**

Indicates engine load for first misfire range: 0 g/rev: Misfire 0.

MISFIRE MARGIN(%)Range: _____ **-100 to 99.22%**

Indicates the misfire detecting margin used during monitoring. A reading of 30% is normal.

MISFIRE MONITORRange: _____ **NOT AVAILABLE/AVAILABLE**

Indicates the misfire monitor status.

MISFIRE RPMRange: _____ **Min.: 0 rpm, Max.: 6,375 rpm**

Indicates engine RPM for first misfire range: 0 rpm: Misfire 0.

MISFIRE RPMRange: _____ **0 to 6375**

Indicates the engine RPM at the time the last misfire code set.

MISFIRE TESTRange: _____ **COMPL/INCMP**

Indicates check mode result for misfire monitor.

MISS HISTORY 1**MISS HISTORY 2****MISS HISTORY 3****MISS HISTORY 4****MISS HISTORY 5****MISS HISTORY 6****MISS HISTORY 7****MISS HISTORY 8**Range: _____ **0 to 65535**

Indicates the total number of misfires detected on each cylinder. These parameters do not update or show any activity until a misfire DTC (P0300) becomes active, then they update every 200 cylinder firing events.

MMODERange: _____ **ON/OFF**

Indicates whether the transmission is in Manual mode (pertains to the Slap-Shift).

- ON when in manual shift gate position (neutral)
- OFF when in position other than the above

MOT BATT TEMP (°)Range: _____ **-30 to 60°C or -22 to 140°F**

Indicates the motor battery, or battery module, temperature.

MOT ECM SIGNALRange: _____ **OK/NG**

Indicates the state of the motor ECM signal. This shows the status of the communication link between the FI ECM and the MOT ECM.

MOTOR DUTY (%)Range: _____ **0 to 100%**

Indicates the duty cycle of the TACM output signal to the motor.

MOTOR POS (V)

Range: _____ 0.0 to 5.0 V

Indicates a feedback signal from the idle speed control motor position sensor on vehicles with a SOHC Mitsubishi engine. The sensor is a variable resistor with a pin that rests on the idle speed control servo plunger. As the plunger extends, output voltage and idle speed increase. As the plunger retracts, voltage and idle speed decrease.

MOTTQLMTX (kgfm)

Range: _____ 0 to 5 kgfm

Indicates the state of the MOTTQLMTX.

MOUNT CTRL SOL**MT CTRL SOL**

Range: _____ ON/OFF

Indicates the state of the mount control solenoid valve. The valve is turned ON to decrease the engine vibration at idle.

MP_LRN

Range: _____ YES/NO

Indicates the learned misfire correction profile status.

MTSW

Range: _____ AT/MT

Indicates the manual transmission/automatic transmission discrimination signal.

NCRKMF

Range: _____ not available

Indicates the crankshaft sensor for misfire detection noise counter.

ND WHL SPD

Range: _____ 0 to 158 mph or 0 to 255 kph

Indicates the non-drive (ND) wheel speed as seen by the electronic brake traction control module (EBTCM).

NLVL**NLVL-1****NLVL-2****NLVLAD**

Range: _____ not available

Indicates the engine base noise level.

NLVLAD

Range: _____ not available

Indicates the knock sensor signal for KCX type detection.

N SWITCH

Range: _____ ON/OFF

Indicates the status of park/neutral switch.

NEUT_SW(MTX)

Range: _____ ON/OFF

Indicates the clutch pedal position switch/neutral switch circuit status.

NO. OF MISFIRESRange: _____ **0 to 255**

Indicates the total number of cylinder firing events detected as misfires during the last 200 crankshaft revolutions.

NON A/CRange: _____ **ON/OFF**

Indicates the A/C installed confirm signal.

NON MMODERange: _____ **ON/OFF**

Indicates whether the transmission is “not” in Manual mode (pertains to the Slap-Shift).

- OFF when in manual shift gate position (neutral, + side, – side)
- ON when in position other than the above

NP SWITCHRange: _____ **ON/OFF**

Indicates the state of the neutral position switch on a manual transmission. It reads ON (electrically closed) with the shift lever in neutral position.

NSXRange: _____ **ON/OFF**

Indicates the state of the NSX, it reads OFF when the clutch pedal is depressed.

NTRBCDRange: _____ **not available**

Indicates the total number of DTCs that the ECM stores.

NUMKEYSRange: _____ **actual**

Indicates the number of keys stored.

O2 (mV)	
O2 #1 (mV)	
O2 #2 (mV)	
O2 B1-S1 (mV)	
O2 B1-S2 (mV)	
O2 B2-S1 (mV)	
O2 B2-S2 (mV)	
FRONT O2 (mV)	
REAR O2 (mV)	
Range:	_____ 0 to 1800 mV
O2 B1-S1 (V)	
O2 B1-S2 (V)	
O2 B2-S1 (V)	
O2 B2-S2 (V)	
O2S B1-S1 (V)	
O2S B1-S2 (V)	
O2S B2-S1 (V)	
O2S B2-S2 (V)	
Range:	_____ 0 to 1.200 V
F UPSTM O2S (V)	
F DNSTM O2S (V)	
R UPSTM O2S (V)	
R DNSTM O2S (V)	
Range:	_____ 0 to 4.98 V

Indicates the exhaust oxygen sensor (O2S) signal voltage. The O2S is the primary sensor that indicates whether the engine is running rich or lean. The voltage signal typically ranges from 0 V to 1 V (0 to 1000 millivolts - mV).

A high signal indicates a rich exhaust; a low signal indicates a lean exhaust. In normal operation, the O2S voltage ranges from 100 to 1000 mV. The O2S must be hot (above 500°F or 260°C), and the system in closed loop before the ECM responds to the sensor signal.

When displayed, O2(mV) is always shown in the center of the top line. The O2S voltage also is shown as EXHAUST O2(mV) in the data list for some functional tests and special data list displays.

Some OBD-I engines have separate oxygen sensors for the front and rear banks. The front O2S voltage is displayed as O2 #2(mV), and the rear O2S voltage is shown as O2 #1(mV).

B1 and B2 refer to banks 1 and 2. Bank 1 is always the bank containing the number 1 cylinder. O2S suffix S1 or UPSTM indicates a pre-catalyst O2S, while suffix S2 or DNSTM indicates a post-catalyst O2S.

O2S prefixes F and R refer to the front and rear cylinder banks on a transverse engine.

During closed loop operation oxygen sensors should range from 100 mV to 900 mV. A lean condition causes both sensors to read below 400 mV, while a rich condition causes readings above 600 mV. At 2500 RPM O2S readings should switch between high and low at least six-to-ten times every ten seconds.

O2 B1-S1 HTR(%)**O2 B1-S2 HTR(%)****O2 B2-S1 HTR(%)****O2 B2-S2 HTR(%)**Range: _____ **0 to 100%**

Indicates the commanded duty cycle of the heater control circuits for oxygen sensors on bank 1 and bank 2.

- The higher the percent, the more the heater circuit ON time resulting in a higher heater temperature.
- The lower the percent, the less time the heater circuit is ON resulting in lower heater temperatures.

O2 B1S1 HTR(ma)**O2 B1S2 HTR(ma)****O2 B2S1 HTR(ma)****O2 B2S2 HTR(ma)**Range: _____ **not available**

Indicates the current of the heated oxygen sensor (HO2S) heater circuit. B1 and B2 refer to banks 1 and 2. Bank 1 is always the bank containing the number 1 cylinder. S1 indicates a pre-catalyst O2S, S2 indicates a post-catalyst O2S.

O2 CROSSCOUNTSRange: _____ **0 to 255**

Indicates the number of times the O2S voltage crossed from the lean region (below 450 mV) to the rich region (above 450 mV) within the last second. The reading indicates how well the O2S is responding to changes in fuel metering and exhaust oxygen content. It does not indicate how well the sensor is operating.

On some engines, the O2S may cool off at idle, and the system may go to open loop. In this case, the sensor does not provide a varying voltage to the ECM, and the reading is 0. Run the engine at fast idle to warm the sensor, return to closed loop, and restore the reading.

O2 HEATER**O2 HEATER B1-S1****O2 HEATER B1-S2****O2 HEATER B1-S3****O2 HEATER B2-S1****O2 HEATER B2-S2****O2S HEATER S1****OXYGEN SENSOR HEATER**Range: _____ **ON/OFF**

Indicates the O2S heater status, it reads ON when the heater is on, usually at idle with a cold exhaust. B1 and B2 refer to banks 1 and 2. Bank 1 is always the bank containing the number 1 cylinder. S1 indicates a pre-catalyst O2S, S2 indicates a post-catalyst O2S and S3 indicates sensor 3. The parameter O2 HEATER refers to that O2S in the B1-S1 position.

O2 MON**O2 MON B1-S2****O2 MON B2-S1****O2 MON B2-S2**Range: _____ **RICH/LEAN**

Indicates whether a particular O2S senses a rich or lean condition with the engine running in closed-loop. Should read:

- RICH when the PCM is shortening the fuel injector pulse width to lean the mixture.
- LEAN when the PCM is lengthening the pulse width to enrich the mixture.

B1 and B2 refer to banks 1 and 2. Bank 1 is always the bank containing the number 1 cylinder. S1 indicates a pre-catalyst O2S, and S2 indicates a post-catalyst O2S. The parameter O2 MON refers to the O2S in the B1-S1 position.

O2B1-S1 HTR CMD**O2B1-S2 HTR CMD****O2B2-S1 HTR CMD****O2B2-S2 HTR CMD**

Range: _____ **YES/NO**

Indicates the commanded state of the heater control circuit for oxygen sensors on banks 1 and 2. The read as follows:

- YES when the sensor heater command is on.
- NO when the sensor heater command is off.

O2OEVAP

Range: _____ **actual**

Indicates that the EVAP purge leak check monitor has completed.

O2S (A/FS) HTR CMPL

Range: _____ **COMPLETE/INCOMPLETE**

Indicates the O2S (A/FS) heater monitor.

O2S (A/FS) HTR ENA

Range: _____ **UNABLE/ENABLE**

Indicates the O2S (A/FS) heater monitor.

O2S (A/FS) MONITOR

Range: _____ **COMPLETE/INCOMPLETE**

Indicates the O2S (A/FS) monitor.

O2S (A/FS) MONITOR

Range: _____ **NOT AVAILABLE/AVAILABLE**

Indicates the O2S (A/FS) monitor.

O2S11 (mV)**O2S12 (mV)****O2S21 (mV)****O2S22 (mV)**

Range: _____ **0 to 1800**

O2S11 (V)**O2S12 (V)****O2S21 (V)****O2S22 (V)**

Range: _____ **not available**

Indicates the exhaust oxygen sensor (O2S) signal voltage. The O2S is the primary sensor that indicates whether the engine is running rich or lean. The voltage signal typically ranges from 0 to 1000 millivolts (mV).

A high millivolt signal indicates a rich exhaust; a low signal indicates a lean exhaust. In normal operation, O2S voltage ranges from 100 to 1000 mV. An O2S must be hot (above 500°F), and the PCM must be operating in closed loop before the PCM responds to the sensor signal.

The 2 digits after O2S identify the sensor location:

- O2S11—The upstream sensor for bank 1
- O2S12—The downstream sensor for bank 1
- O2S21—The upstream sensor for bank 2
- O2S22—The downstream sensor for bank 2.

O2S11_FAULT**O2S21_FAULT**

Range: _____ **YES/NO**

Indicates a heated exhaust oxygen sensor fault.

The 2 digits after O2S identify the sensor location:

- O2S11—The upstream sensor for bank 1
- O2S21—The upstream sensor for bank 2

OBDSID

Range: _____ **not available**

Indicates the on-board system identification.

OCT ADJ

Range: _____ **OPEN/CLSD**

Indicates the octane adjust status.

OD INHIBIT

Range: _____ **ON/OFF**

Indicates the overdrive cancel switch/hold switch status.

OD OFF LIGHT

Range: _____ **ON/OFF**

Indicates the transmission control indicator light.

OIL LIFE (%)

Range: _____ **0 to 100%**

Indicates the ECM calculated current oil life remaining as a percentage based on mileage, driving conditions, temperature, and load conditions.

OIL PRES

Range: _____ **0 to 999 kPa or 0 to 147 psi**

Indicates the engine oil pressure on some vehicles. This may be a calculated value derived from an oil pressure voltage signal.

OIL PRESS(V)

Range: _____ **0 to 5.0 V**

Indicates engine oil pressure as a voltage.

OPEN MALFUNC**OPN MALFUNC**

Range: _____ **ON/OFF**

Indicates an open side malfunction.

OPSC

Range: _____ **actual**

Indicates the oil pressure switch control counter.

OSFMFLG

Range: _____ YES/NO

Indicates the output shaft speed failure mode.

OutShftSp (RPM)

Range: _____ 0 to vehicle max.

Indicates a PCM calculated RPM value for the transmission output shaft. The output shaft speed sensor (OSS) is a voltage-generating magnetic pickup. The PCM converts the voltage signal of the OSS to an RPM value.

OXS1 TEST

Range: _____ COMPL/INCOMPL

Indicates check mode result for HO2S (bank 1).

OXS2 TEST

Range: _____ COMPL/INCOMPLI

Indicates check mode result for HO2S (bank 2).

OVER ENG TM (S)

Range: _____ actual time

Indicates the total time the engine was operated over the established RPM limit in seconds.

P/N SWITCH

Range: _____ ON/OFF

Indicates the park/neutral switch status.

P/S SIGNAL

Range: _____ OFF/ON

Indicates the steering wheel has been turned (moved) since the ignition key was turned on. This usually remains on during the entire key on drive cycle.

P/S PRESS SW**PSP_SW**

Range: _____ ON/OFF

Indicates the power steering pressure switch.

PARK/NEU POS**ParkNeuPos**

Range: _____ P-N or -R-DL

Indicates whether an automatic transmission is in park or neutral or in one of the drive ranges. It should read:

- P-N- if the transmission is in either park or neutral.
- -R-DL if the transmission is in any forward gear or reverse.

The park/neutral switch is closed in park or neutral and open in any forward gear or reverse.

PART LOAD

Range: _____ not available

Indicates part load. Monitors the O2S and it will set a code; Rich or Lean.

PCM IN VTD FAIL

Range: _____ YES/NO

Indicates the ECM received a good password from the passlock module, the vehicle has started, and a failure has occurred. The ECM continues to enable fuel.

PCM RESETRange: _____ **YES/NO**

Indicates the internal PCM reset status, it reads YES only when an internal PCM reset occurred and NO under normal operating conditions.

PDSWRange: _____ **ON/OFF**

Indicates the status of the variable capacity A/C compressor pressure switch.

PFINHRange: _____ **LOW/HIGH**

Indicates the status of the output voltage level of the PFINH line.

PNPRange: _____ **ON/OFF**

Indicates the clutch pedal position switch/neutral switch circuit status.

PNP SWITCHRange: _____ **P-N/GEAR**

Indicates the status of the park/neutral position (PNP) switch on an automatic transmission. With the shift lever is in "P" or "N" position, the reading is P-N. If the selector is in any other position, the reading is GEAR.

POS COUNTRange: _____ **0 to 255**

Indicates the number of cogs on the flywheel, an intact flywheel should have 180 cogs. The crankshaft position sensor is used to determine this value.

PRES UP VSVRange: _____ **ON/OFF**

Indicates the ECM command status for the vacuum switching valve (VSV) that controls the pressure up valve. This valve diverts intake manifold vacuum from the fuel pressure regulator, causing fuel rail pressure to rise.

PRESS R SOLRange: _____ **ON/OFF**

Indicates the status of the pressure regulator cutoff solenoid valve. Vacuum to the fuel pressure regulator is cut to prevent fuel percolation and make hot restart easier.

PRI PRESS (MPa)Range: _____ **0.3 to 0.9 MPa**

Indicates the status of the solenoid that regulates Primary Transmission Line Pressure.

PRI SPEED (rpm)Range: _____ **variable**

Indicates the primary pulley speed. Display value approximately matches engine speed.

PRNDL SWRange: _____ **see below**

Indicates the gear presently selected according to the PRNDL switch.

Readings for most models are LOW, 2ND, 3RD, 4TH, and P/N. On some vehicles, it may be D1, D2, D3, D4, NEUT, REV, and PARK. If the transmission is between gears or the switch sends an invalid signal,???? displays.

PROM ID

Range: _____ **0 to 99999**

Indicates the identification numbers of the programmable read-only memory (PROM) installed in the ECM. The PROM is a replaceable electronic device that contains the operating program and calibration values for a specific vehicle, engine, and accessory package combination. PROMs are often revised and new PROMs are issued to cure a driveability problem or otherwise improve operation. Because PROMs are interchangeable, it is possible for the wrong or outdated PROM to be installed.

The PROM ID may be a 2-, 3-, 4-, or 5-digit number, depending on year and model. Compare the PROM ID to the manufacturer's specifications to determine if the correct PROM is installed.

Some service manuals refer to the PROM as the MEMCAL because it contains both memory and calibration functions.

PSMOTTRQ**PSSOC****PSTBAT****PSVBATPT**

Range: _____ **ON/OFF**

Indicates the IMA power saving information when an individual voltage of the BCM is out of suitable range. Reads ON when in power save mode.

PSVBATAL

Range: _____ **ON/OFF**

Indicates the IMA power saving information when all voltage of the BCM is out of range. It reads ON when in power save mode.

PULSE CAL ST**PULSER CAL STATUS**

Range: _____ **1/0**

Indicates the CRK pulser learn calculation status, which is used for misfire detection. It reads 1 if ECM is under calculation (the ECM is calculating the pulser tolerance compensation value).

PULSER F/B LEARN

Range: _____ **variable**

Indicates the status of the CRK pulser feedback learn condition. It reads OK or COMPLETED if this learning is completed, NG or NOT COMPLETED if not.

To run the learn program, test drive the vehicle on a level road, decelerate (with the throttle fully closed) from an engine speed of 5000 rpm to 3000 rpm with the 1st gear (a/t.m/t).

PURGE CUT SOL

Range: _____ **ON/OFF**

Indicates the canister drain cut valve control signal.

PURGE CUT VSV

Range: _____ **ON/OFF**

Indicates the PCM command for the vacuum switching valve (VSV) that closes the evaporative emissions (EVAP) purge valve. If the EVAP system operates properly, ON means the system has stopped purging.

PURGE DENSITY

Range: _____ **-50 to 350**

Displays the evaporative purge density during system operation. Normal range is -40 to 0 at idle.

PURGE DUTY(%)

Range: _____ 0 to 100%

Indicates the evaporative emission canister purge valve duty cycle.

PURGE FLOW(%)

Range: _____ 0 to 102.4%

Indicates the presence of purge flow from the canister to the engine. Percent reading should increase as purge flow increases.

PURGE VOL (STPS)

Range: _____ 0 to 65

Indicates the position of the purge volume control valve motor as a step count. The valve regulates the amount of airflow through the EVAP canister during purge.

As the stepper-motor count increases, canister airflow increases. During heavy load, expect a high stepper-motor count; during warm idle expect a low count.

QCKMIL

Range: _____ ON/OFF

Indicates the status of the quick MIL. If two trip or driving cycle is canceled, then the MIL turns on and a DTC is stored once failure is detected. Mode ON.

QXREF

Range: _____ not available

Indicates the status of the learned QIDL at IDLE.

R FUEL LEVEL (V)

Range: _____ 0 to 5.0 V

Indicates the fuel level in the right tank as voltage and reads as follows:

- About 0.8 V = empty tank
- About 2.5 V = full tank

R SWITCH

Range: _____ ON/OFF

Indicates the transmission R range switch.

R WIND DEF SW

Range: _____ ON/OFF

Indicates the rear defrost switch status.

RAD FAN

Range: _____ ON/OFF

Indicates the fan control signal.

RE CVS VALVE

Range: _____ ON/OFF

Indicates the status of the return signal of the evaporative canister vent shut solenoid valve. It reads ON when the circuit is normal and the solenoid valve is on.

RE VTEC SOL**REL VTEC SOL**

Range: _____ ON/OFF

Indicates the status of the VTS return signal, it reads ON when the circuit is normal and VTS is on. An OFF reading indicates a circuit problem.

RE VTEC SOL2Range: _____ **ON/OFF**

Indicates the status of the VTEC solenoid valve 2 signal, it reads ON when the circuit is normal and VTS2 is on. An OFF reading indicates a circuit problem.

REAR O2 HEATERSRange: _____ **ON/OFF**

Indicates the rear (downstream) exhaust gas oxygen sensor heater status.

REDUCED POWERRange: _____ **ACTIVE/INACTIVE**

Indicates whether the PCM is receiving a signal from the TAC module that a throttle actuator control system fault is occurring, it reads:

- ACTIVE if a fault occurs and the PCM limits the engine power
- INACTIVE under normal operating conditions

REDUCE TORQ 1Range: _____ **ON/OFF**

Indicates the reduce torque signal 1 status.

REDUCE TORQ 2Range: _____ **ON/OFF**

Indicates the reduce torque signal 2 status.

REF 1(V)Range: _____ **0 to 5.0 V**

Indicates the voltage sensed on the 5-volt reference 1 circuit at the control module.

REF 1(V) STATUSRange: _____ **PASS/FAIL**

No definition is available for this parameter at this time.

REF 2(V)Range: _____ **0 to 5.0 V**

Indicates the voltage sensed on the 5-volt reference 2 circuit at the control module.

REF 2(V) STATUSRange: _____ **PASS/FAIL**

No additional information is available for this parameter.

REL TP (%)**REL TP SENSOR (%) (°)**Range: _____ **0 to 100% or 0 to 180°**

Indicates the status of the relative throttle position sensor on a drive by wire (DBW) system. The reading is the ECM calculated throttle opening as percent or degrees, it should increase as the throttle opens.

RELIEF VALVE SOLRange: _____ **ON/OFF**

Indicates the status of the relief valve solenoid. To avoid the abnormal pressure rising and surge noise, the ECM controls the solenoid valve to ON (open).

REQ TORQUERange: _____ **0 to 100%**

Indicates the amount of torque that is requested by the PCM as a percentage.

RESTART FANRange: _____ **ON/OFF**

Indicates the status of the restart fan control, which runs to remove heat from the engine compartment after the engine shuts down. It reads ON when the main fan is running.

RETARD ACTIONRange: _____ **NO/YES/FAIL**

Indicates the retard action taken by the ECM, it reads:

- NO (range) = No retarding
- YES (range) = Retarding
- FAIL (range) = Retard impossible

RETARD REQUESTRange: _____ **NO/YES/FAIL**

Displays the retard request from the traction control system (TCS) control unit status, it reads:

- NO = No retard requesting
- YES = Retard requesting
- FAIL = TCS system failure

REV SELECTEDRange: _____ **ON/OFF**

Indicates the transmission Reverse range switch.

REVERSE LOCK SOLRange: _____ **ON/OFF**

Indicates the status of the reverse select lock solenoid. When turned ON, it is impossible to select "Reverse Gear".

RO2FT1(%)Range: _____ **-35 to 35%**

Indicates the rear O2S fuel trim, bank 1 status.

RO2FT2(%)Range: _____ **-35 to 35%**

Indicates the rear O2S fuel trim, bank 2 status.

RPHRSTRRange: _____ **LOW/HIGH**

Indicates the status of the rear peakhold reset. The 2VI sensor peakhold voltage is reset by this peakhold reset signal from the ECM.

RPMRange: _____ **actual****RPM COARSE**Range: _____ **0 to 7968 rpm****RPM FINE**Range: _____ **0 to 1992 rpm**

Indicates the engine speed.

RPMDESRange: _____ **0 to engine max.**

Indicates desired engine speed as calculated by the PCM for base idle. This reading should always be close to actual idle RPM.

Rr ACM SOL CURRENT

Range: _____ **variable**

Indicates the output current to the rear ACM control module as amperes.

Rr ACM SOL MAX CURRENT

Range: _____ **variable**

Indicates the maximum current output to the rear ACM control module for the current ignition cycle as amperes.

Rr ACM SOL MIN CURRENT

Range: _____ **variable**

Indicates the minimum current output to the rear ACM control module for the current ignition cycle as amperes.

S SWITCH

Range: _____ **ON/OFF**

Indicates the transmission S range switch.

S/C RELAY

Range: _____ **ON/OFF**

Indicates the ECM command to the magnetic clutch relay for the supercharger. The relay should be energized and the clutch engaged when the reading is ON.

S/C SOLENOID

Range: _____ **ON/OFF**

Indicates the ECM command status of the speed control (S/C) (cruise) solenoid. It reads ON when the solenoid is energized and that the vehicle cruise control is engaged.

S/C TARGET

Range: _____ **0 to vehicle max.**

Indicates the speed at which the cruise control is set by the driver.

S/C VAC SOL

S/C VENT SOL

Range: _____ **OPEN/CLSD**

Indicates the ECM output commands to the speed control (S/C) vacuum and vent solenoids, which regulate the cruise control servo. The readings are ON whenever the solenoids are energized to increase or to vent vacuum.

The S/C VAC SOL and S/C VENT SOL readings usually have the following relationships with throttle position control:

Table 18-6 Vent and vacuum solenoid relationships

S/C Vacuum Solenoid	S/C Vent Solenoid	Throttle Position
ON	OFF	Accelerate
ON or OFF	ON	Decelerate
OFF	OFF	Steady

SC_ACT_SW

Range: _____ **ON/OFF**

Indicates the speed control actuator switch on.

SC_SET_LMP
Range: _____ **ON/OFF**

Indicates the speed control set indicator.

SCCS
SCCS(V)
Range: _____ **0 to 10.00 V**

Indicates the speed control command switch (SCCS) voltage.

SEC PRESS (MPa)
Range: _____ **0.5 to 0.9 MPa**

Indicates the status of the solenoid that regulates Secondary Transmission Line Pressure.

SEC SPEED (rpm)
Range: _____ **variable**

Indicates the secondary pulley speed. Display value approximately matches speedometer.

SEGRP(%)
Range: _____ **0 to 100%**

Indicates the EGR valve stepping motor position.

SEGRP DES(%)
Range: _____ **0 to 100%**

Indicates the EGR motor position desired.

SELTESTDTC
Range: _____ **actual**

Indicates the diagnostic trouble codes.

SET LAMP
Range: _____ **ON/OFF**

Indicates the status of the cruise control indicator light on the instrument panel.

SET VHCL SPD
Range: _____ **0 to vehicle max.**

Indicates the selected cruise control speed.

SFTCMD (H)
Range: _____ **not available**

Indicates the status of the SFT command, which determines whether the ECM is in functional test mode.

SFTRIM 1 (%)
SFTRIM 2 (%)
Range: _____ **-25 to 35%**

Indicates if the PCM is commanding a rich or a lean short-term fuel mixture correction.

Readings range from -25% to +35%, with 000% as the midpoint. A number above zero indicates a PCM command for a short-term rich mixture correction. A number below zero indicates the PCM is commanding a short-term lean mixture.

The ST FUEL number leads the long-term fuel (LT FUEL) number. When a pattern or trend of short-term corrections to fuel-metering occur, long-term fuel (LT FUEL) responds with a similar correction.

Compare ST FUEL numbers to injector on-time. Numbers above zero indicate increased on-time, below zero indicates decreased on-time. The ST FUEL corrections operate only in closed loop. In open loop, it goes to a fixed value.

SHIFT A/1(%)

Range: _____ 0 to 100%

Indicates the shift solenoid A/1.

SHIFT B/2(%)

Range: _____ 0 to 100%

Indicates the shift solenoid B/2.

SHIFT C/3(%)

Range: _____ 0 to 100%

Indicates the shift solenoid C/3.

SHIFT SOL A

Range: _____ ON/OFF

Indicates the status of shift solenoid 1

SHIFT SOL B

Range: _____ ON/OFF

Indicates the status of shift solenoid 2

SHIFT SOL C

Range: _____ ON/OFF

Indicates the status of shift solenoid 3

SHIFT SOL D

Range: _____ ON/OFF

Indicates the status of shift solenoid 4

SHIFT SOL E

Range: _____ ON/OFF

Indicates the status of shift solenoid 5

SHIFT INDICATOR

Range: _____ ON/OFF

Indicates the status of the shift up indicator light on the instrument panel. It is turned ON when the ECM judges that driving conditions request shift up for fuel economy.

SHIFT/CLUTCH SW**SHIFT/CLUTCH SWT**

Range: _____ ON/OFF

Indicates the status of the cruise A/T shift position. Reading should be ON (switch electrically closed) when the A/T shift position switch indicates D3 or D4.

ShiftSol1**ShiftSol2****ShiftSol3****ShiftSol4**

Range: _____ ON/OFF

Indicates the PCM commands for the 1, 2, and 3 shift solenoids, it reads ON when the PCM has commanded the shift solenoid to energize.

ShiftSol1Fault	
ShiftSol2Fault	
ShiftSol3Fault	
ShiftSol4Fault	
Range:	_____ ON/OFF
Indicates whether the PCM detects a fault in the shift solenoid circuits, it reads YES only when a fault is present.	
SHRTFT1(%)	
Range:	_____ -35 to 35%
Indicates the status of the short term fuel trim 1.	
SHRTFT2(%)	
Range:	_____ -35 to 35%
Indicates the status of the short term fuel trim 2.	
SHRTFT11(%)	
Range:	_____ -35 to 35%
Indicates the status of the short term fuel trim bank 1, sensor 1.	
SHRTFT12(%)	
Range:	_____ -35 to 35%
Indicates the status of the short term fuel trim bank 1, sensor 2.	
SHRTFT21(%)	
Range:	_____ -35 to 35%
Indicates the status of the short term fuel trim bank 2, sensor 1.	
SHRTFT22(%)	
Range:	_____ -35 to 35%
Indicates the status of the short term fuel trim bank 2, sensor 2.	
SLIP REV (rpm)	
Range:	_____ variable
Indicates the difference between the engine speed and the primary pulley speed.	
SMCOIL A	
Range:	_____ ON/OFF
Indicates the step motor coil "A" energizing status.	
SMCOIL B	
Range:	_____ ON/OFF
Indicates the step motor coil "B" energizing status.	
SMCOIL C	
Range:	_____ ON/OFF
Indicates the step motor coil "C" energizing status.	
SMCOIL D	
Range:	_____ ON/OFF
Indicates the step motor coil "D" energizing status.	
SO2S B2 H CUR (mA)	
Range:	_____ variable
Indicates the amount of current the ECM is applying to the bank 2 sensor 2 oxygen sensor heater circuit.	

SO2S H CUR (mA)Range: _____ **variable**

Indicates the amount of current the ECM is applying to the bank 1 sensor 2 oxygen sensor heater circuit.

SOAK TIME (min)Range: _____ **actual time**

Indicates the soak time, time since the engine last ran, in minutes.

SOC (%)Range: _____ **0 to 100%**

Indicates the battery charge status, which is the remaining capacity of the battery module.

SOL VRange: _____ **ON/OFF**

Indicates the status of the cold start solenoid. The solenoid should be ON when engine coolant temperature (ETC) is above 95°C, intake air temperature (IAT) is above 80°C and the engine has been running for about 1, it should be OFF at all other times.

SOLMON1Range: _____ **0.0 A / 0.6 to 0.7 A**

Indicates the torque converter clutch solenoid valve monitor current.

SOLMON2Range: _____ **0.8 A / 0.3 to 0.6 A**

Indicates the pressure control solenoid valve A (line pressure solenoid valve) monitor current.

SOLMON3Range: _____ **0.6 to 0.7 A / 0.4 to 0.6 A**

Shows the pressure control solenoid valve B (secondary pressure solenoid valve) monitor current as amperage.

SPARK ADV(°)**SPK ADV(°BTDC)****SPRKADV(°)**Range: _____ **-25 to 50°**

Indicates the spark advance status.

SPD (NC)**SPD (NC0)****SPD (NC2)****SPD (NC3)**Range: _____ **0 to 12750 RPM**

Indicates the RPM of the trans internal direct clutch (Main, Number 2, or Number 3 clutch drum) assemblies.

SPD (NT)Range: _____ **0 to 12750 RPM**

Indicates the RPM of the trans input shaft.

SPD(SP2) KPH**SPD(SP2) MPH**Range: _____ **0 to 255 KPH or 0 to 158 MPH**

Indicates the transmission output shaft speed in KPH or MPH.

SPD TESTRange: _____ **COMPL/INCOMPL**

Indicates the status of the CHECK MODE vehicle speed sensor test.

SRC_CANRange: _____ **ENABLE/DISABLE**

Indicates is the starter motor relay is enabled.

ST ALPHA (%)**ST ALPHA B2 (%)**Range: _____ **0 to 200%**

Indicates whether the ECM is commanding a rich or a lean mixture as part of the short-term fuel metering correction strategy. On a V-type engine, ST ALPHA is the bank 1 value and ST ALPHA B2 is bank 2. The value changes in response to changing patterns of the long-term fuel trim corrections.

Short-term fuel trim ranges from 0% to 200% with 100% as the midpoint. At 100% the PCM is not adjusting the injector pulse width or the engine is running in a fail-safe mode. At readings above 100%, the engine is running lean while the PCM is commanding a short-term rich mixture correction. At a reading below 100%, the engine is running rich while the PCM is commanding a short-term lean mixture correction.

ST FUEL TRIM (COUNTS)**ST FUEL TRIM B1 (COUNTS)****ST FUEL TRIM B2 (COUNTS)**Range: _____ **0 to 255**

Indicates the short-term fuel trim correction as a step count. If the oxygen sensor voltage indicates a lean mixture, the step count increases and the ECM commands a longer fuel injector pulse width. Bank 1 (B1) contains cylinder #1.

ST TRIM (%)**ST TRIM B1 (%)****ST TRIM B2 (%)****ST TRIM-1 (%)****ST TRIM-2 (%)****TRIM B1-S1 (%)****TRIM B1-S2 (%)****TRIM B2-S1 (%)****TRIM B2-S2 (%)**Range: _____ **-25 to 25%, -100 to 100% or 0 to 200%**

Indicates the short-term fuel trim correction as a percentage. The short term fuel trim represents a short term correction to fuel delivery by the PCM in response to the amount of time the oxygen sensor (O2S) voltage spends above or below the 450 mV threshold.

Trim number prefixes B1 and B2 correlate to banks 1 and 2. Bank 1 is always the bank that contains the number 1 cylinder. TRIM number suffix S1 indicates a pre-catalyst O2S input, while suffix S2 indicates a post-catalyst O2S input.

Short-term fuel trim ranges from -100% to +100%, -25% to +25%, or 0 to 200% depending on the vehicle. Depending on which scale is used, zero or 100 percent serves as the midpoint. A number above the midpoint indicates the PCM is commanding a long-term rich mixture correction. A number the midpoint indicates the PCM is commanding a lean mixture.

Under certain conditions such as an extended idle and a high ambient temperature, the canister purge may cause the short term fuel trim to read in the negative range during normal operation. The fuel trim values at maximum may indicate an excessively rich or lean system.

Short-term fuel trim leads the long-term trim (LT TRIM). When a pattern or trend of short-term corrections to fuel-metering occur, LT TRIM responds with a similar correction.

Compare ST TRIM readings to injector on-time. Numbers above zero indicate increased on-time, while numbers below zero indicate decreased on-time. LT TRIM corrections operate only in closed loop. In open loop they revert to a fixed value.

ST TRM AVG1 (%)**ST TRM AVG2 (%)**

Range: _____ **0 to 100%**

Indicates the average of all long term fuel trim cells as percentage. The short term fuel trim cells are rated, for the amount of which they are used.

For example, an idle cell is rated higher than a wide open cell. If a fueling malfunction occurs in the idle cell and the wide open cell, the average would be more affected by the idle cell than the wide open cell.

A low value indicates that the fuel system is rich and fuel delivery is being reduced. A high value indicates that a lean condition exists and the PCM compensates by adding fuel. When the average of the cells reach a predetermined high or low, a fuel trim DTC sets.

ST1

Range: _____ **OFF/ON**

Indicates the status of the ignition switch starter signal. ON indicates cranking.

STA SIGNAL**STARTER****STARTER SIG**

Range: _____ **ON/OFF**

Indicates whether the starter is engaged, it reads ON when the engine is cranking. The ECM increases fuel-injection volume during engine cranking.

START CLNT (°)**START ETC: (°)**

Range: _____ **-40 to 199°C or -40 to 389°F**

Indicates the engine coolant temperature (ETC) at startup.

On some vehicles, the ECM checks the engine coolant temperature (ECT) sensor reading at the moment the ECM is turned on. The ECM then stores this reading in memory until the next time the engine is stopped and restarted. If the engine has not run for several hours, the coolant temperature may be close to ambient air temperature. It will be much higher on a hot restart.

Compare the START CLNT reading to the coolant temperature reading immediately after startup. With a cold engine the two readings should be equal. The coolant temperature reading should rise as the engine warms up. The START CLNT reading should not. If both readings stay the same, there is a problem in the sensor circuit.

START ENRICH**WARMUP ENRICH**

Range: _____ **ON/OFF**

Indicates the ECM control status (mode) of the fuel injection system. During start or warm-up mode, the ECM monitors ignition, coolant and air temperature, airflow, throttle position, and O2S data to control injection pulse-width, timing, and idle speed.

START IAT (°)

Range: _____ **-40 to 199°C or -40 to 389°F**

Indicates the intake air temperature (IAT) at start up when the ignition switch is turned on.

START RPM
Range: _____ not available

Indicates the engine speed when the starter is engaged.

STARTER CONTROL

STARTER CTRL
Range: _____ ON/OFF

Indicates the status of the starter control. It reads ON when the starter cut relay is turned on, which allows the starter motor to engage.

STARTER RELAY

Range: _____ ON/OFF

Indicates the state of the starter relay, it reads ON with the starter engaged.

STARTER SWITCH

STARTER SWT
Range: _____ ON/OFF

Indicates the status of the starter motor switch, it reads ON with the starter engaged.

STOP LAMP SW

Range: _____ ON/OFF

Indicates the state of the stop lamp switch, it reads ON when the brake pedal is depressed and OFF when released.

SUB BRAKE SWITCH

Range: _____ ON/OFF

Indicates the status of the idle stop sub brake switch, it reads ON when idle is stopping.

SVSM

SVSOUT

SVSP

Range: _____ 12V/0V

Indicates the voltage applied by the ECU to the SVS terminals.

SWITCH STATE

Range: _____ HIGH/LOW

Indicates the position of a specific actuator switch when conducting certain functional tests. A circuit is generally LOW when actuated.

SYS GUARD

Range: _____ ON/OFF

Indicates the system guard.

SYS GUARD

Range: _____ OFF/ON

Indicates the status of the ETCS system guard.

SYSFAIL

Range: _____ variable

Indicates a count of system failures, a count is recorded when a DTC is set.

TAC MTR CMD(%)

Range: _____ 0 to 100%

Indicates the required duty cycle to maintain a desired throttle position. The scan tool will display a higher value if more effort is required to move the throttle to the desired position, such as

physical resistance. The scan tool will display a lower value if less effort is required to move the throttle to the desired position.

TAC/PCM COMM FLT

Range: _____ **OK/FLT**

Indicates the communication status between the TAC Module and the PCM, it reads:

- OK under normal operating conditions
- FLT if a failure is detected

TACHO_GAUGE

Range: _____ **actual**

Indicates the tachometer. Displays the engine rpm.

TACM RELAY

Range: _____ **ON/OFF**

Indicates the status of the throttle actual control relay, which supplies power to the TAC module. It reads ON when the relay is energized.

TANK BYP VSV

Range: _____ **ON/OFF**

Indicates the status of the tank bypass vacuum switching valve for active test support data.

TANK PRES(V)**TANK PRESS (V)**

Range: _____ **0.0 to 5.0 V**

Indicates the output signal of the fuel tank pressure sensor as voltage. When tank pressure equals atmospheric pressure, the reading is about 1.3 to 1.7 V. The higher the voltage, the greater the pressure.

TANK PRES**TANK PRS (kPa)(inHg)(mmHg)**

Range: _____ **variable**

Indicates the difference between fuel tank pressure, or vacuum, and the outside air pressure.

TANK TEMP (°)

Range: _____ **-30 to 224°C or -22 to 435°F**

Indicates the fuel temperature within the fuel tank. The PCM uses this parameter to accurately test and monitor the evaporative emissions system.

TARG LINE

Range: _____ **variable**

Indicates the target modifier pressure/target pressure control solenoid pressure status.

TARGET ENG SPD

Range: _____ **variable**

Indicates the desired rpm.

TARGET TH VALVE**TARGET TH VLV (ETCS)(°)**

Range: _____ **0 to 180°**

Indicates the target throttle valve position which is the valve position the ECM is attempting to maintain. The ECM calculates the target angle from the accelerator position sensor input and the driving conditions.

TARGIDL (RPM)Range: _____ **variable**

Indicates the target idle, which is the idle speed the ECM is attempting to maintain.

TAT TERMINALRange: _____ **ON/OFF**

Indicates the DLC tat terminal.

TC/TE1Range: _____ **ON/OFF**

Indicates the connection status of the TC/TE1 terminals of the DLC-3 (OBD-II) connector.

TC-SDLRange: _____ **ON/OFF or YES/NO**

Indicates the status of the transaction control serial data link.

TCC (%)Range: _____ **0 to 100%**

Indicates the duty cycle of the pulse-width-modulated (PWM) signal output to the torque converter clutch (TCC) solenoid. Reads 0% with the TCC solenoid closed (TCC not applied). Reads 100% with the TCC solenoid fully open (TCC applied).

TCC COMMANDRange: _____ **ON/OFF**

Indicates the torque converter clutch (modulated) status.

TCC SOL(%)Range: _____ **0 to 100%**

Indicates the torque converter clutch control solenoid.

TCC/CC BRAKE SWRange: _____ **OPEN/CLSD**

Indicates the current state of the torque converter clutch (TCC)/cruise brake pedal switch. This is used to control stop lamps and as a redundant cruise control disengagement.

TCCFaultRange: _____ **YES/NO**

Indicates the presence of a PCM detected fault in the torque converter clutch circuit. Reads YES only when a fault is present.

TCCMACT (RPM)Range: _____ **0 to vehicle max.**

Indicates a PCM calculated value of torque converter slippage. The value is derived by subtracting the turbine speed from the engine RPM. The reading should be less than 50 RPM when the TCC is applied (TCC parameter reads 95% or greater).

TCILFaultRange: _____ **YES/NO**

Indicates whether a fault has occurred in the Transmission Control Indicator Lamp circuit.

TCINHRange: _____ **LOW/HIGH**

Indicates the status of the traction control inhibitor signal.

TCS FUEL-CUTRange: _____ **ON/OFF**

Indicates the fuel cut control request from the TCS control unit to the ECM, which results from wheel slippage being detected by the TCS. The request is to reduce engine power in order to restore traction.

TCS INHRange: _____ **ON/OFF**

Indicates the torque reduction inhibit signal (traction control system) status.

TCS-PGM-FIRange: _____ **ON/OFF or YES/NO**

Indicates the status of the traction control serial data link.

TCS STANDBYRange: _____ **LOW/HI**

Indicates a request from the TCS control unit to the ECM to reduce engine power in order to restore traction, which results from wheel slippage being detected by the TCS. It reads LOW when wheel slip is detected.

TEMP_GAUGERange: _____ **-40 to 399°F or -40 to 199°C**

Indicates the temperature gauge.

TEN TERMINAL**TEST**Range: _____ **ON/OFF**

Indicates the TEN terminal (data link connector) status.

TGT VLV TMNG(°)Range: _____ **ON/OFF**

Indicates the target valve timing status.

THIDL (°)Range: _____ **0 to 180°**

Indicates the ECM learned throttle position as degrees of throttle opening.

THROTL IDL POSRange: _____ **ON/OFF**

Indicates whether or not throttle position sensor detecting idle. ON: Idling.

THROTL POS (%)Range: _____ **Min.: 0 %, Max.: 100 %**

Indicates the throttle position. 10 to 22 %: Idling. Calculated value based on VTA1.

THROTL MTR OPN DUTY(%)Range: _____ **0 to 100%**

Indicates the ETCS throttle sensor opener position value Number 1. The normal value range is 0 to 40% when idling. When the accelerator pedal is depressed, the duty cycle increases.

THROTL MTR CLSD DUTY(%)Range: _____ **0 to 100%**

Indicates the ETCS throttle sensor opener position value Number 1. The normal value range is 0 to 40% when idling. When the accelerator pedal is released quickly, the duty cycle increases.

THROTL POS (%)Range: _____ **Min.: 0 %, Max.: 100 %**

Indicates the throttle sensor position. Recognition value for throttle opening angle on ECM.

- 0 %: Accelerator pedal released
- 64 to 96 %: Accelerator pedal fully depressed

THROTL SSR #1 AD (V)Range: _____ **Min.: 0 V, Max.: 4.98 V**

Indicates throttle sensor opener position Number 1 (AD): 0.6 to 0.9 V.

THROTTLE (°)**THROTTLE (%)****THROTTLE POS****TP SENSOR (%)****TP (%)****TPS (%)****TPS1 (%)****TPS2 (%)**Range: _____ **0 to 180° or 0 to 100%**

Indicates the ECM calculated throttle opening as degrees or percent based on input from the throttle position (TP) sensor signal voltage.

Some vehicles display these values as degrees. A reading of 82° or more indicates wide-open throttle. Closed-throttle readings vary because of the idle speed control (ISC) motor position and throttle body adjustments.

When a percentage displays, a reading of 0% indicates a closed throttle and 100% indicates a wide-open throttle. A percentage usually displays on a system with an autoranging TP sensor. The ECM resets the 0 to 100% range in relation to TP sensor voltage as new minimum and maximum TP sensor voltages are sensed by the system.

THROTTLE MTRRange: _____ **ON/OFF**

Indicates whether or not throttle actuator control permitted: ON: Idling, read value with engine switch on. (IG) (Do not start engine).

THROTTLE MTR (%)Range: _____ **Min.: 0 %, Max.: 100 %**

Indicates throttle actuator. 0.5 to 40 %: Idling..

THROTTLE MTR AMPSRange: _____ **Min.: 0 A, Max.: 19.92 A or Min.: 0 A, Max.: 80 A**

Indicates throttle actuator current. 0 to 3.0 A: Idling.

THROTTLE POSITION SENSOR (V)

TP (V)

TPS (ECM)

TPS (ETS)

TPS (V)

MIN. TPS (V)

TPS 1 (V)

TPS 2 (V)

TPS1 (V)

TPS2 (V)

Range: _____ **0 to 5.0 V**

Indicates the throttle position (TP) sensor signal voltage, which determines throttle opening, a 1 or 2 in the name indicates the vehicle uses more than one TP sensor. Readings should be:

- Low voltage at closed throttle
- High voltage at wide-open throttle

The full range of the TP sensor voltage readings available to the ECM is 0 to about 5.1 V and typical readings are as follows:

- 0.5V, closed throttle, engine at idle
- 4.0V, full throttle, engine under heavy acceleration

The MIN TPS voltage is the base throttle position value used at idle.

THROTTLE SWRange: _____ **CLSD/OPEN**

Indicates the position of the throttle switch inside the idle speed control (ISC) motor:

- CLSD indicates the throttle is closed and the engine should be at idle speed (TP sensor should be less than 20°).
- OPEN indicates the engine is off idle (TP sensor should be more than 20°).

THROTTLE VLV (°)Range: _____ **0 to 180°**

Indicates the status of the throttle valve position (ETCS), which is the relative throttle valve angle controlled by the TACV module.

ThrPosMODERange: _____ **see below**

Indicates the throttle closed position as calculated by the PCM based on the throttle position (TP) sensor signal. It should read C/T (closed throttle) at idle and during deceleration, P/T (part throttle) at cruise or during moderate acceleration, and WOT (Wide-Open Throttle) at de-choke on crank, A/C cutout, or during maximum acceleration.

THRTL CMD VAL(V)Range: _____ **0.0 to 4.98 V**

Indicates the ETCS commanded throttle position value.

THRTL CMND VALRange: _____ **Min.: 0 V, Max.: 4.9804 V**

Indicates throttle position command value: 0.5 to 4.8 V.

THRTL LEARN VAL(V)Range: _____ **0.0 to 5.0 V**

Indicates the ETCS throttle valve fully closed learned position value.

THRTL LEARN VAL(V)Range: _____ **Min.: 0 V, Max.: 5 V**

Indicates the throttle valve fully closed (learned value): 0.4 to 0.8 V.

THRTL MTR CLOSE (%)Range: _____ **0 to 100%**

Indicates the ETCS throttle motor opening duty ratio. The normal value range is 0 to 40% when idling. When the accelerator pedal is released quickly, the duty cycle increases.

THRTL MTR CLOSE (%)Range: _____ **Min.: 0 %, Max.: 100 %**

Indicates throttle actuator closed duty ratio. 0 to 40 %: Idling. When accelerator pedal is released quickly, duty ratio increases.

THRTL MTR OPEN (%)Range: _____ **Min.: 0 %, Max.: 100 %**

Indicates throttle actuator opening duty ratio. 0 to 40 %: Idling. When accelerator pedal is depressed, duty ratio increases.

THRTL MTR OPN (%)Range: _____ **0 to 100%**

Indicates the ETCS throttle motor opening duty ratio. The normal value range is 0 to 40% when idling. When the accelerator pedal is depressed, the duty cycle increases.

THRTL POS1 (V)Range: _____ **Min.: 0 V, Max.: 5 V**

Indicates throttle position Number 1.

- 0.5 to 1.2 V: Throttle fully closed
- 3.2 to 4.8 V: Throttle fully open

THRTL POS2 (%)Range: _____ **Min.: 0 %, Max.: 100 %**

Indicates the throttle sensor positioning #2. Calculated value based on VTA2.

THRTL POS2 (V)Range: _____ **Min.: 0 V, Max.: 5 V**

Indicates throttle position Number 2.

- 2.0 to 2.9 V: Throttle fully closed
- 3.2 to 4.8 V: Throttle fully open

THRTL RELAYRange: _____ **ON/OFF**

Indicates the status of the throttle relay.

THRTL REQ POS (V)Range: _____ **-Min.: 0 V, Max.: 5 V**

Indicates the throttle requirement position. 0.5 to 1.0 V: Idling.

THRTL REQ POS(V)Range: _____ **0.0 to 5.0 V**

Indicates the ETCS throttle requirement position voltage. 0.5V to 1.0V at idle is normal.

THRTL SSR #1 AD(V)Range: _____ **0 to 4.98 V**

Indicates the ETCS throttle sensor opener position value Number 1 (AD). The normal value range is 0.6V to 0.9V.

THRTL SSR #1 (V)Range: _____ **0 to 4.98 V**

Indicates the ETCS throttle sensor opener position value Number 1. The normal value range is 0.6V to 0.9V.

THRTL SSR #2 (V)Range: _____ **0 to 4.98 V**

Indicates the ETCS throttle sensor opener position value Number 2. The normal value range is 2.26V to 2.6V.

THRTL SSR #1 (V)Range: _____ **Min.: 0 V, Max.: 4.9804 V**

Indicates throttle sensor opener position. Typical readings are: 0.6 to 0.9 V.

THRTL SSR #2 (V)Range: _____ **Min.: 0 V, Max.: 4.9804 V**

Indicates throttle sensor opener position Number 2: 2.2 to 2.6 V.

THROTTLE SWRange: _____ **ON/OFF**

Indicates the throttle switch.

TIME**TIME ON**Range: _____ **0 to 1092 minutes**

Indicates a continuous record of engine running time as minutes and seconds. The value returns to zero whenever the engine is shut down, or if run time exceeds the maximum.

This feature can help to isolate intermittent driveability problems that may occur within a time period after vehicle startup or after reaching cruising speed, for example.

TIME DTC CLEARRange: _____ **Min.: 0 second, Max.: 65,535 seconds**

Indicates time after DTC cleared: Equivalent to time after DTCs erased.

TIMESRange: _____ **actual**

Indicates the time since engine start.

TMBLVLRange: _____ **LOW/HIGH**

Indicates the voltage level of the transmission signal (TMB) circuit.

TORQUERange: _____ **variable**

Indicates the net engine torque.

TP (%)**TP SENSOR (V)(%)**Range: _____ **0 to 100% or 0.0 to 5.0 V**

Indicates the absolute throttle opening value as calculated by the ECM from the voltage input from the TP sensor. DBW = drive by wire.

Operating range (idle):

- 4% to 14% or 0.2V to 0.7V (Fully closed)
- 4% to 20% or 0.2V to 1.0V (DBW)

TP 1&2 AGREE**TPS 1&2 AGREE**Range: _____ **YES/NO**

Indicates the results of a control module test that compares the signals from the throttle position (TP) sensors 1 and 2.

- YES indicates that TP sensors 1 and 2 voltages correspond to the same throttle position.
- NO indicates that TP sensors 1 and 2 voltages correspond to different throttle positions.

TP A-B (°)Range: _____ **0 to 180°**

Indicates the correlation angle between TP sensor A and TP sensor B.

TP R(%)**TP_REL(%)**Range: _____ **not available**

Indicates the relative throttle position.

TP SENSOR-A (V)**TP SENSOR-B (V)**Range: _____ **0.0 to 5.0 V**

Indicates throttle position sensor (A or B) signal voltage. The ECM/PCM compares the voltage from throttle position sensor A and throttle position sensor B to detect failures.

TP SWITCHRange: _____ **ON/OFF**

Indicates the status of the throttle position switch, it reads ON when the throttle is fully closed, and OFF at all other times.

TP(V)Range: _____ **0.0 to 5.0 V**

Indicates the throttle position in voltage.

TP_FAULTRange: _____ **YES/NO**

Indicates a throttle position sensor fault.

TP_MODERange: _____ **not available**

Indicates a throttle position status.

TP=TPS (V)Range: _____ **0.0 to 5.1 V**

Indicates the throttle position (TP) sensor voltage signal, which is proportional to the throttle plate opening. Expect to see low voltage at closed throttle and high voltage at wide-open throttle. The

full range of TP voltage available to the PCM is 0 to approximately 5.1 volts. A typical TP voltage range might be about 0.5 volt at idle to 4.5 volts at wide-open throttle.

TP1(%)
Range: _____ 0 to 100%

Indicates the status of throttle position sensor 1.

TP1(V)
Range: _____ 0.0 to 5.0 V

Indicates the throttle position sensor 1 output voltage.

TP2(%)
Range: _____ 0 to 100%

Indicates the status of throttle position sensor 2.

TP2(V)
Range: _____ 0.0 to 5.0 V

Indicates the throttle position sensor 2 output voltage.

TPS1 LRN MIN(V)
Range: _____ 0.0 to 5.0 V

Indicates the learned minimum voltage for TP sensor 1 as determined by the control module this ignition cycle.

TPS2 LRN MIN(V)
Range: _____ 0.0 to 5.0 V

Indicates the learned minimum voltage for TP sensor 2 as determined by the control module this ignition cycle.

TRACTION CTRL
Range: _____ YES/NO

Indicates whether the vehicle has a traction control system (TCS).

TRACTION SIGNAL
Range: _____ ON/OFF

Indicates the status of the traction control system (TCS) and reads ON when TCS is on.

TPCT
TPCT(V)
Range: _____ 0.0 to 5.0 V

Indicates the lowest closed throttle voltage.

TPCT (V)
Range: _____ not available

Indicates the most recent throttle position (TP) sensor voltage at closed throttle (throttle position closed throttle).

TPS(%)
Range: _____ 0 to 100%

Indicates the throttle position.

TPS(V)
Range: _____ 0.0 to 5.0 V

Indicates the throttle position sensor signal voltage.

TQR/ECTRange: _____ **ON/OFF**

Indicates the torque reduction execution signal.

TR_VRange: _____ **0.0 to 1.5 V**

Indicates the transmission signal return voltage measured at PCM pin 64. Voltage varies by what gear the transmission is operating in:

Table 18-7 TR_V voltage

Gear	Voltage*	Gear	Voltage*
Park	0.0 V	Overdrive	1.5 V
Reverse	1.5 V	Manual 2	0.0 V
Neutral	1.5 V	Manual 1	0.0 V
Readings may vary (+ or -) by 0,3V			

TRIPRange: _____ **YES/NO**

Indicates whether a trip has occurred. A trip is a complete ignition on, engine run, ignition off cycle that tests all components and systems on an OBD-II vehicle.

TRIP Count**TRIP_CNT**Range: _____ **0 to 255**

Indicates the number of OBD-II drive cycles completed since the last DTC P1000 (monitor readiness) set.

TRIP_SWRange: _____ **ON/OFF**

Indicates the status of the trip reset switch.

TrnCtrlIndLampRange: _____ **ON/OFF**

Indicates the status of the transmission control indicator lamp. It reads ON when "Overdrive Cancel" is requested and an indicator lamp is lit.

TrnCtrlSwRange: _____ **ON/OFF**

Indicates the status of the transmission control switch (TCS). The switch is normally open and the value reads OFF. When the driver requests overdrive cancellation, the switch closes and the reading is ON.

TrnFluidTmp (V)Range: _____ **0.0 to 5.0 V**

Indicates the voltage signal from the transmission fluid temperature (TFT) sensor. A low voltage reading indicates a high fluid temperature, while a high voltage reading indicates a low fluid temperature.

TRVL AFTER MILRange: _____ **actual distance**

Indicates the distance traveled since the malfunction indicator lamp (MIL) was turned on.

TurbSpds (RPM)

Range: _____ 0 to 8192

Indicates the speed of the transmission turbine shaft.

TWC TEMP

Range: _____ 572 to 1949°F or 300 to 1065°C

Indicates the PCM calculated temperature of the catalytic converter, which is useful for determining if the catalyst monitor test has run.

UPLVR

Range: _____ ON/OFF

Indicates the status of the gear shifter (Slap Shift).

- ON when selector lever is + side
- OFF when selector lever is other than the above

VAC CUT BYPASS

Range: _____ ON/OFF

Indicates the PCM command to the vacuum cut bypass valve. It only reads ON when the valve is opened to perform an EVAP system leak-check.

VACUUM PMP

Range: _____ ON/OFF

Indicates the key off status of the EVAP system pump.

VAF RESET SIG

Range: _____ ON/OFF

Indicates the vane airflow (VAF) reset status. During warm engine idling the reading should be ON, at 2500RPM it should be OFF.

VAPOR PRES CALC

Range: _____ -5.632 kPa to 715.264 kPa

Indicates the calculated fuel vapor pressure inside the fuel tank on monitored inputs from the vapor pressure sensor. With the fuel tank filler cap removed, a reading of 0 kPa is normal.

VAPOR PRES CALC

Range: _____ Min.: -5.632 kPa, Max.: 7153264 kPa

Indicates the vapor pressure (calculated). 0 kPa: Fuel tank cap removed. Pressure inside fuel tank monitored by vapor pressure sensor.

VAPOR PRES VSV

Range: _____ ON/OFF

Indicates the PCM command to the vacuum switching valve (VSV) used to actuate the vapor pressure valve. The vapor pressure valve lets the EVAP system detect and isolate leaks, it reads ON when the VSV opens the valve.

VAPOR PRESS TANK

Range: _____ Min.: -4.125 kPa, Max.: 2.125 kPa

Indicates the pressure inside fuel tank monitored by vapor pressure sensor.

- Vapor pressure 0 kPa: Fuel tank cap removed

VARI INTAKE VSV

Range: _____ ON/OFF

Indicates the status of the vacuum switching valve (VSV) for intake runner control.

VBAT(V)Range: _____ **0 to 16.0 V**

Indicates the battery positive voltage.

VEH LOAD(%)Range: _____ **Min.: 0 %, Max.: 25700 %**

Indicates the vehicle load: Actual vehicle load.

VEH SPEED**VEHICLE SPEED**Range: _____ **0 to vehicle max.**

Indicates vehicle speed, the value is calculated by the ECM, PCM, or TCM based on input pulses from the vehicle speed sensor (VSS).

The ECM uses vehicle speed primarily for torque converter clutch (TCC) engagement, although it also is an important value for electronic cruise control systems.

Manual transmission vehicles without cruise control and some automatic transmission vehicles without a TCC do not have a VSS. The scan tool may display a parameter for these models, but the reading will always be 0.

VENT CONT VALVERange: _____ **ON/OFF**

Indicates the PCM command status to the EVAP canister control valve. It should read ON when the PCM has commanded the vent valve closed to prevent the canister from venting.

VHCL SPD CUTRange: _____ **NON/CUT**

Indicates the vehicle cruise condition.

- NON—Vehicle speed is maintained at the ASCD set speed
- CUT—Vehicle speed decreased to excessively low compared with the ASCD set speed, and ASCD operation is cut off

VIAS S/VRange: _____ **ON/OFF**

Indicates the state of the variable induction air control system solenoid valve which controls the vacuum signal from the intake manifold and reads as follows:

- 1,800 to 3,600 RPM—ON
- All other conditions—OFF

VPS SOLRange: _____ **ON/OFF**

Indicates the PCM command status of the valve pulse system control solenoid valve. To reduce fuel consumption, the ECM commands the solenoid valve not to lift both intake and exhaust valves without controlling the ignition system during cruising and acceleration. It reads ON when the VSP is active, the ECM command is to not to lift the valve.

VPS STATUSRange: _____ **ON/OFF**

Indicates the status of the valve pause system. It reads ON when the valve action has been overridden by a PCM command.

VREF(V)
 Range: _____ **0.0 to 5.12 V**

Indicates the reference voltage that system sensors operate on. Nominal reference voltage is 5.0 V. Depending on system calibration and charging system voltage, readings may vary a few tenths of a volt. Some models normally read about 6.5 V; verify with DVOM.

VRIS SOL VALVE
 Range: _____ **ON/OFF**

Indicates the variable resonance induction solenoid valve.

VRISV1
VRIS SOL VLV 1
 Range: _____ **ON/OFF**

Indicates the variable resonance induction solenoid valve 1.

VRISV2
VRIS SOL VLV 2
 Range: _____ **ON/OFF**

Indicates the variable resonance induction solenoid valve 2.

VSA REQ TH (°)
 Range: _____ **0 to 180°**

Displays the throttle position in degrees as requested by the vehicle stability assist (VSA) control module.

VSS
 Range: _____ **0 to vehicle max.**

Indicates vehicle speed as determined by ECM input pulses from the vehicle speed sensor (VSS). The ECM calculates the actual speed.

The ECM uses vehicle speed primarily for torque converter clutch (TCC) engagement, although it also is an important value for electronic cruise control systems.

Manual transmission vehicles without cruise control and some automatic transmission vehicles without a TCC do not have a VSS. The scan tool may display a parameter for these models, but the reading will always be 0.

VSS_FAULT
 Range: _____ **YES/NO**

Indicates a vehicle speed fault.

VT_ACT1(°)
VT ACT2(°)
 Range: _____ **variable**

Indicates actual valve timing.

VT_DIFF1(°)
VT_DIFF2(°)
 Range: _____ **variable**

Indicates the difference between the target and the actual valve timing.

VT_DUTY1(%)
 Range: _____ **0 to 100%**

Indicates the camshaft position commanded duty cycle 1 status.

VT_DUTY2(%)
Range: _____ 0 to 100%

Indicates the camshaft position commanded duty cycle 2 status.

VTC SOL DUTY (%)
Range: _____ 0 to 100%

Indicates the duty cycle of the VTC control solenoid valve. It reflects the drive percentage required to make the CMP actuator achieve a target angle.

VTC STATUS
Range: _____ ON/OFF

Indicates the status of the VTC system, it reads ON when the VTC system is active.

VTD AUTOLRN TMR
Range: _____ ON/OFF

Indicates whether the vehicle theft deterrent (VTD) system is in learn mode and has not timed out (10 minutes). It reads ON during learn mode.

VTD F_DISUNTIL
Range: _____ ON/OFF

Indicates ON if the vehicle theft deterrent (VTD) system has detected a fault with the ignition turned on and a valid theft deterrent DTC present until the ignition is turned off. The vehicle may be disabled on the next ignition cycle if the fault remains current. OFF will display if the system is OK and the theft deterrent system is inactive.

VTD FAIL ENABLD
Range: _____ YES/NO

Indicates whether the PCM received the correct password from the passlock module and a failure has occurred. The PCM continues to enable fuel.

VTD FUEL
Range: _____ ON/OFF

Indicates whether the vehicle theft deterrent (VTD) system is preventing fuel delivery, it reads:

- ON if the ECM has not received the correct password from the passlock module and is disabling the fuel system
- OFF during normal operation

VTD FUEL DISABL
Range: _____ ON/OFF

Indicates whether the vehicle theft deterrent (VTD) system is preventing fuel delivery and reads as follows:

- ON only if the ECM has not received the correct password from the passlock module and is disabling the fuel system.
- OFF during normal operation.

VTD FUEL ENABLE
Range: _____ ON/OFF

Indicates ON if the vehicle theft deterrent (VTD) system has detected a fault after the ignition has been turned on and a valid theft deterrent password has been received. The engine will continue to run until the ignition is turned off. The vehicle may be disabled on the next ignition cycle if a fault is detected and a valid password is not received. OFF will display if the system is OK and the theft deterrent system is inactive.

VTD PASSWORD OKRange: _____ **YES/NO**

Indicates whether a valid vehicle theft deterrent (VTD) password was received.

VTEC INFORMATIONRange: _____ **not available**

Indicates the status of the variable valve timing system. When the VTEC valve shifts to high valve, it has a possibility of sticking. This detects the failure with the knock sensor.

VTEC PRES SW**VTEC PRES SW B1****VTEC PRES SW B2****VTEC PS SW**Range: _____ **ON/OFF**

Indicates the state of the VTEC Oil pressure switch. When oil pressure is applied, the switch changes from ON to OFF. The reading should be ON at low RPM.

A B1 and B2 in the parameter name indicates multiple switches used on a V-type engine. Bank 1 is the cylinder bank that contains cylinder 1.

VTEC SOL**VTEC SOL 1****VTEC SOL 2****VTEC SOL B1****VTEC SOL B2**Range: _____ **ON/OFF**

Indicates the state of the VTEC solenoid valve (Spool valve), it reads ON when the solenoid is energized. The ECM opens the solenoid valve to change the actuation of the valve timing and lift to improve performance. The change point depends on the engine load conditions.

Solenoid valve designations are:

- Solenoid 1 is used to adjust the Low-Mid change point.
- Solenoid 2 is used to adjust the Mid-High change point.
- B1 is the cylinder bank that contains cylinder 1.
- B2 is the cylinder bank that does not contains cylinder 1.

VVT AIM ANGL #1(%)Range: _____ **0 to 100%**

Indicates the variable valve timing (VVT) AIM (target) angle for the bank 1 intake cam. 0% during a requested intrusive operation at idle is considered normal.

VVT AIM ANGL #2(%)Range: _____ **0 to 100%**

Indicates the variable valve timing (VVT) AIM (target) angle for the bank 2 intake cam. 0% during a requested intrusive operation at idle is considered normal.

VVT CHNG ANGL#1 (°)Range: _____ **Min.: 0°FR, Max.: 60°FR**

Indicates the variable valve timing (VVT) change angle (bank 1). 0° from rest: Idling. Displacement angle during intrusive operation.

VVT CHNG ANGL#2 (°)

Range: _____ Min.: 0°FR, Max.: 60°FR

Indicates the variable valve timing (VVT) change angle (bank 2). 0° from rest: Idling.
Displacement angle during intrusive operation.

VVT CHNG ANGL #1(°)

Range: _____ 0°FR to 60°FR

Indicates the variable valve timing (VVT) change angle FR (From Rest) for the bank 1 intake cam. 0 to 5° at idle during a requested intrusive operation is considered normal.

VVT CHNG ANGL #2(°)

Range: _____ 0°FR to 60°FR

Indicates the variable valve timing (VVT) change angle FR (From Rest) for the bank 2 intake cam. 0 to 5° at idle during a requested intrusive operation is considered normal.

VVT CONTROL

Range: _____ ON/OFF

Indicates the ECM command to the variable valve timing (VVT) system, which is used to advance or retard camshaft timing, it reads ON when VVT is active. The VVT uses a hydraulic motor to change camshaft gear position.

VVT CTRL B1

Range: _____ ON/OFF

Indicates the variable valve timing (VVT) control (bank 1) status.

VVT CTRL B2

Range: _____ ON/OFF

Indicates the variable valve timing (VVT) control (bank 2) status.

VVT EX CHG ANG1(°)

Range: _____ 0°FR to 60°FR

Indicates the variable valve timing (VVT) change angle FR (From Rest) bank 1 intake cam. 0 to 5° at idle during a requested intrusive operation is considered normal.

VVT EX CHG ANG1 (°)

Range: _____ Min.: 0°FR, Max.: 60°FR

Indicates the variable valve timing (VVT) exhaust change angle (bank 1). 0° from rest: Idling.

VVT EX CHG ANG2(°)

Range: _____ 0°FR to 60°FR

Indicates the variable valve timing (VVT) change angle FR (From Rest) bank 2 intake cam. 0 to 5° at idle during a requested intrusive operation is considered normal.

VVT EX CHG ANG2 (°)

Range: _____ Min.: 0°FR, Max.: 60°FR

Indicates the variable valve timing (VVT) exhaust change angle (bank 2). 0° from rest: Idling.

VVT EX HOLD B1(%)

Range: _____ 0 to 100%

Indicates the variable valve timing (VVT) exhaust hold duty ratio learning value for the bank 1 exhaust cam. 30% to 70% at idle during a requested intrusive operation is considered normal.

VVT EX HOLD B2(%)Range: _____ **0 to 100%**

Indicates the variable valve timing (VVT) exhaust hold duty ratio learning value for the bank 2 exhaust cam. 30% to 70% at idle during a requested intrusive operation is considered normal.

VVT EX OCV D B1(%)Range: _____ **0 to 100%**

Indicates the variable valve timing (VVT) OCV bank 1 exhaust cam commanded operation duty cycle. 10% to 50% during a requested intrusive operation at idle is considered normal.

VVT EX OCV D B2(%)Range: _____ **0 to 100%**

Indicates the variable valve timing (VVT) OCV bank 2 exhaust cam commanded operation duty cycle. 10% to 50% during a requested intrusive operation at idle is considered normal.

VVT OCV DUTY B1(%)Range: _____ **0 to 100%**

Indicates the variable valve timing (VVT) OCV bank 1 intake cam commanded operation duty cycle. 10% to 50% during a requested intrusive operation at idle is considered normal.

VVT OCV DUTY B2(%)Range: _____ **0 to 100%**

Indicates the variable valve timing (VVT) OCV bank 2 intake cam commanded operation duty cycle. 10% to 50% during a requested intrusive operation at idle is considered normal.

VVTL AIM ANGL#1 (%)Range: _____ **Min.: 0 %, Max.: 100 %**

Indicates the variable valve timing (VVT) aim angle (bank 1). 0 %: Idling. VVT duty signal value during intrusive operation.

VVTL AIM ANGL#2 (%)Range: _____ **Min.: 0 %, Max.: 100 %**

Indicates the variable valve timing (VVT) aim angle (bank 2). 0 %: Idling. VVT duty signal value during intrusive operation.

WAC_FAULTRange: _____ **YES/NO**

Indicates a wide open throttle A/C cut-off fault.

WAC=WOT A/CRange: _____ **ON/OFF**

Indicates whether the PCM is preventing the A/C system from operating due to undesirable engine conditions. These include operation during engine cranking and wide-open throttle.

On most vehicles, OFF means that the PCM senses undesirable conditions and is currently preventing the A/C clutch from energizing. ON means the PCM is allowing A/C operation.

VAPOR PRESS PUMPRange: _____ **Min.: 33.853 kPa, Max.: 125.596 kPa**

Indicates the pressure inside fuel tank monitored by vapor pressure sensor.

WARM UPS CYC DTC CLEARRange: _____ **0 to 255 counts**

Indicates the warm-up cycle after DTC cleared: Number of warm-up cycles after DTC cleared.

WARM-UPS W/O NON-EMISSION FAULTS**Range:** _____ **0 to 255 counts**

Indicates the number of warm-up cycles without a detected non-emission fault. The parameter will increment to 255, then resets to 0 unless a fault occurs.

- 0 displays if a fault occurs and remains until the fault is corrected.
- Clearing codes or disconnecting PCM power resets the counter to 0.

WARM-UPS W/O EMISSION FAULTS**Range:** _____ **0 to 255 counts**

Indicates the number of warm-up cycles without a detected emission fault. The parameter will increment to 255, then resets to 0 unless a fault occurs.

- 0 displays if a fault occurs and remains until the fault is corrected.
- Clearing codes or disconnecting PCM power resets the counter to 0.

WASTEGATE SOL**Range:** _____ **0 to 100%**

Indicates the drive percentage of the wastegate solenoid valve, which regulates turbocharger boost pressure.

WIDE OPEN THROT**Range:** _____ **YES/NO**

Indicates the status of the wide-open throttle switch, it reads YES when the throttle is completely open. The engine must be running for this parameter to change from NO to YES. With the key on and the engine off, a fully open throttle should produce a maximum throttle position (TP) sensor voltage indication; but this parameter should read NO.

WOT SW**Range:** _____ **ON/OFF**

Indicates the state of the wide-open throttle (WOT) switch parameter, which is calculated by the ECM. It reads ON only when the throttle plate is wide open.

ZRDY**Range:** _____ **ON/OFF**

Indicates the status of the ZRDY, which inhibits power supplied to the TACV motor. It reads ON when the power supply to the TACV motor has stopped.

Generic OBD-II Parameters

This section defines generic OBD-II parameters. To find the description of a specific parameter, locate the parameter name in the index and then go to the listed page.

AAT(°)

Range: _____ **variable**

Indicates the ambient air temperature (AAT) as degrees. Data may be obtained directly from an AAT sensor or calculated by the ECM from other sensor signals.

AIR

AIR STAT

Range: _____ **NOT USED/UPS/DNS/OFF**

Indicates the status of the secondary air injection system. Readings show how the air is being routed. Possible readings include upstream (UPS), downstream (DNS), and atmosphere (OFF).

AIRFLOW(g/s)

Range: _____ **variable**

Indicates the PCM calculated mass airflow (MAF) based on the MAF sensor output. Readings are in grams-per-second, cubic-meters-per-hour, or kilograms-per-hour based. The MAF sensor is located between the air cleaner and the throttle body. The MAF sensor measures the mass air flowing to the engine. The PCM uses this value to calculate the injector pulse width needed for stoichiometry (air/fuel). MAF sensor readings should be low at idle and should increase as the throttle opens.

APP D(%)

APP E(%)

APP F(%)

Range: _____ **0 to 100%**

Indicates absolute accelerator pedal position. The output signal is a proportional percentage to the input voltage (when proportional) or 100% minus the proportional percentage (when inverse proportional).

BARO(kPa)

BARO(inHg)

Range: _____ **variable**

Indicates barometric pressure. Readings may be obtained directly from a BARO or MAP sensor, or calculated by the ECM from other sensor signals.

On some systems, the BARO value is stored in ECM memory at "ignition key on" and also under certain driving conditions. Clearing the memory may result in inaccurate BARO values.

CATEMP11(°)

CATEMP21(°)

CATEMP12(°)

CATEMP22(°)

Range: _____ **variable**

Indicates the temperature of the catalyst substrate for the indicated cylinder bank or oxygen sensor (O2S). For example, CATEMP11 is the reading from bank 1 sensor 1, which is the upstream O2S. CATEMP12 is the reading from bank 1 sensor 2, which is the downstream O2S. Readings may be obtained directly from a dedicated sensor or calculated by the ECM from other sensor signals.

CLR DIST (km) or (mi)Range: _____ **0 to 65535**

Indicates the distance accumulated since the diagnostic trouble codes were cleared using a scan tool or possibly when the battery was disconnected. If the distance exceeds 65,535 km (40,722 mi) traveled, then the value will remain at 65,535 km and will not reset to zero. This is used for Inspection/Maintenance information purpose.

COOLANT(°)Range: _____ **-40 to 199°C or -40 to 389°F**

Indicates engine coolant temperature (ECT), which is supplied to the PCM by the ECT sensor. The ECT sensor is a thermistor installed in the engine coolant passages. The PCM converts ECT sensor voltage signals to temperature readings.

Typical readings with a fully warmed engine running at idle are 185° to 220°F (85° to 105°C). A reading of -40° C or -40°F may indicate an open in the sensor or the sensor circuit. A reading above 185°C or 366°F may indicate a short in the sensor or the sensor circuit.

ECT(°)Range: _____ **-40 to 199°C or -40 to 389°F**

Indicates engine coolant temperature (ECT). Readings are typically supplied directly to the PCM by the ECT sensor. On some models the ECM calculates the reading based on a cylinder head temperature (CHT) or engine oil temperature (EOT) sensor signal.

Typical readings for a fully warmed engine running at idle are 185° to 220°F (85° to 105°C). A reading of -40°C or -40°F may indicate an open in the sensor or the sensor circuit. A reading above 185°C or 366°F may indicate a short in the sensor or the sensor circuit.

EGR ERR(%)Range: _____ **-100 to 99.22%**

Indicates exhaust gas recirculation (EGR) error rate as a percentage. The EGR system control and feedback devices differ, therefore an actual or commanded status cannot be shown. The value is calculated as actual EGR minus commanded EGR multiplied by commanded EGR.

For example: 5% - 10% = -5%, multiplied by 10% = -50%.

EGR PCT(%)Range: _____ **0 to 100%**

Indicates the opening of the exhaust gas recirculation (EGR) valve as a percentage. A reading of 0% indicates the valve is closed (no EGR flow), a 100% reading indicates the valve is fully open (maximum EGR flow).

ENGINE RPMRange: _____ **0 to engine max.**

Indicates the engine speed, which is computed internally by the PCM based on reference pulses from the ignition system or a crankshaft sensor.

EQ RATRange: _____ **variable ratio**

Indicates the air/fuel (A/F) ratio as commanded by the ECM. To obtain the actual A/F ratio, multiply the stoichiometric A/F ratio (14.7:1) by the displayed value. A conventional oxygen sensor (O2S) displays EQ RAT only when the engine is operating in open loop. A value of 1.0 displays when running in closed loop. A wide range, or linear, O2S displays the EQ RAT in both open and closed loop.

EQ RAT11
 EQ RAT12
 EQ RAT13
 EQ RAT14
 EQ RAT21
 EQ RAT22
 EQ RAT23
 EQ RAT24
 EQ RAT31
 EQ RAT32
 EQ RAT41
 EQ RAT42

Range: _____ **0 to 1.999**

Indicates the air/fuel (A/F) ratio as commanded by the ECM for each oxygen sensor (O2S) on vehicles that use linear, or wide-ratio, oxygen sensors. For example, EQ RAT11 displays the ratio for bank 1 sensor 1 (upstream O2S), and EQ RAT12 is the ratio for bank 1 sensor 2 (downstream O2S). To calculate the actual A/F ratio, multiply the stoichiometric A/F ratio (14.7:1) by the displayed value.

EVAP PCT(%)

Range: _____ **0 to 100%**

Indicates the evaporative emission (EVAP) purge control valve opening as a percentage. A reading of 0% indicates the valve is closed (no purge flow), and a 100% reading indicates the purge valve is fully open (maximum purge flow).

EVAP_VP(Pa)

Range: _____ **-8192 to 8192 Pa**

EVAP_VP(H2O)

Range: _____ **-32.887 to 32.884 inH2O**

Indicates the evaporative emissions (EVAP) system vapor pressure, which is obtained from a fuel pressure sensor in the tank or in the evaporative system vapor line.

FLI(%)

Range: _____ **0 to 100%**

Indicates the amount of fuel in the tank as a percentage of tank capacity. A 0% reading indicates an empty fuel tank and 100% indicates a full tank. Readings may be taken directly from a sensor or calculated by the ECM from other sensor signals.

FRP

Range: _____ **0 to 655350 kPa or 0 to 111 psi**

Indicates fuel rail pressure relative to atmospheric pressure. Displayed pressure should be the same as an actual gauge reading taken at the fuel rail.

FUEL PRESS

Range: _____ **0 to 768 kPa or 0 to 111 psi**

Indicates the actual pressure in the fuel rail.

FUEL SYS1

FUEL SYS2

Range: _____ **NOT USED/OL/CL/OL DRV/OL FLT/CL FLT**

Indicates the fuel system operating status for bank 1 and bank 2. Displayed values are:

- OL = Open loop (not all conditions were met to allow closed loop)
- CL = Closed loop (oxygen sensor is supplying feedback for fuel control)

- OL DRV = Open loop due to driving conditions (rapid accelerations or decelerations)
- OL FLT = Open loop due to a fault in the system
- CL FLT = Closed loop but failure with one or more oxygen sensors (one sensor may be controlling fuel delivery)

During open loop, the PCM ignores the main O2S signal. The PCM uses main O2S feedback to correct fuel injection duration during closed loop. On a cold engine, OL should display until a reliable feedback signal is received from the O2S. On a warm engine running either at idle or at 2500 RPM with no load CL should display.

Power enrichment during hard acceleration or deceleration during fuel cutoff should cause an OL DRV reading. An OL FLT reading indicates the system is operating in open loop due to a detected failure. A CL FLT reading indicates a failure has been detected by at least one O2S, but the system is still capable of maintaining closed loop operation.

IAT(°)

Range: _____ variable °C or °F

Indicates the temperature of the intake air entering the engine. Readings may be taken directly from an intake air temperature (IAT) sensor, typically installed in the air cleaner, or calculated by the ECM based on input from other sensors. The PCM converts the sensor voltage to temperature readings.

IGN TIMING(°)

Range: _____ variable

Indicates the degrees of ignition timing advance or retard. If timing is retarded, a minus (-) sign appears with the reading.

INTAKE AIR(°)

Range: _____ variable °C or °F

Indicates the temperature of the intake air. The intake air temperature (IAT) sensor is a thermistor, typically installed in the air cleaner. A 5-volt reference is applied to the sensor. As temperature increases, sensor resistance decreases, providing the voltage signal to the PCM. The PCM converts the sensor voltage to temperature readings.

The engine control module uses the temperature parameter to control the amount of injected fuel, based on the density of the incoming air.

LOAD(%)

Range: _____ 0 to 100%

Indicates the relative engine load. The PCM calculates this value by dividing the actual manifold airflow volume by the maximum possible manifold airflow volume. A high number indicates a heavy load, a low number a lighter load.

LOAD ABS(%)

Range: _____ 0 to 25700%

Indicates the pumping efficiency of the engine expressed as a percentage. The PCM calculates this value based on the mass of the air entering the cylinders on the intake stroke. High numbers indicate heavy loads, low numbers indicate lighter loads. Readings reflect the volumetric efficiency of the engine at wide open throttle.

LOAD PCT(%)

Range: _____ 0 to 100%

Indicates the relative engine load. The value is determined by dividing the actual manifold airflow volume by the maximum possible manifold airflow volume for gas engines. Actual fuel flow is substituted for manifold airflow volume for diesel engines. For all engines, compensation factors

for pressure and temperature are also used in the calculation. A high number indicates a heavy load, a low number a lighter load.

LONG FT3(%)

LONG FT2(%)

LONG FT1(%)

LONG FT4(%)

Range: _____ **-100 to 99.22%**

Indicates the long term fuel trim (FT) for each of the fuel banks on the engine. Displayed values represent the operation and long term correction of the fuel mixture on the vehicle, with 0% as the midpoint. Numbers above zero indicate the PCM is commanding a long term rich mixture correction, which increases fuel injector duration. Numbers below zero indicate the PCM is commanding a lean mixture, which decreases fuel injector duration. A reading of -100% indicates the maximum lean mixture and 99.22% indicates the maximum rich mixture.

The LONG FT numbers follow short term trim (SHRTFT) numbers to make long term fuel metering corrections, in response to a pattern of short term corrections.

LT TRIM B1(%)

LT TRIM B2(%)

Range: _____ **-25 to +25%**

Indicates the operation and long term correction of the fuel mixture for bank 1 and bank 2. The midpoint of the range is 0%. Numbers above zero indicate the PCM is commanding a rich fuel mixture correction. Numbers below zero indicate the PCM is commanding a lean fuel mixture correction.

The LT TRIM numbers follow the short-term trim (ST TRIM) numbers to make long-term fuel metering corrections, in response to a pattern of short term corrections.

Compare LT TRIM numbers to injector on-time. Numbers above zero indicate increased on-time, while numbers below zero indicate decreased on-time. LT TRIM corrections operate only in closed loop. In open loop they revert to a fixed value.

MAF(g/s)

Range: _____ **0 to 655.35 g/s**

Indicates the flow rate of the intake air entering the engine. The display shows airflow volume as grams-per-second. Readings may be taken directly from the mass airflow (MAF) sensor, or calculated by the PCM based on input from other sensors.

MAP

Range: _____ **0 to 205 kPa or 0 to 60.7 inHg**

Indicates the PCM calculated manifold absolute pressure (MAP) based on the MAP sensor voltage signal. When MAP is displayed in kPa, the reading should be approximately 100 to 102 kPa with the engine off and the manifold close to atmospheric pressure at sea level. When the engine is running manifold vacuum increases and the kPa reading drops. The higher the manifold vacuum, the lower the kPa reading. On a turbocharged engine, the kPa reading should rise above 100 as boost is applied.

When MAP is displayed in inHg, the reading should be about 29.9 inHg with the engine off and the manifold close to atmospheric pressure at sea level. When the engine is running with high manifold vacuum, the MAP reading in inHg drops. On a turbocharged engine, the reading rises above 30 as boost is applied.

MIL

Range: _____ **ON/OFF**

Indicates the PCM command to the malfunction indicator lamp (MIL) on the instrument panel. Readings should correspond to the actual state of the MIL. Suspect a MIL circuit problem if the value does not match the MIL condition.

MIL DIST

Range: _____ **0 to 65535 mi or km**

Indicates the distance the vehicle has been driven since the malfunction indicator lamp (MIL) was switched on by the PCM. The display reads 0 unless the MIL has been commanded on. Once activated, the accumulated kilometers or miles display. When PCM memory is cleared, or if 40 warm-up cycles occur without the MIL setting conditions reoccurring, the display resets to 0.

O2 B1-S1(mV)**O2 B1-S2(mV)****O2 B1-S3(mV)****O2 B1-S4(mV)****O2 B2-S1(mV)****O2 B2-S2(mV)****O2 B2-S3(mV)****O2 B2-S4(mV)**

Range: _____ **0 to 1800 mV**

Indicates the oxygen sensor (O2S) signal as millivolts (mV). The O2S is the primary sensor that indicates whether the engine is running rich or lean. The O2S generates a voltage signal that ranges from 0 to 1000 mV. A high millivolt signal indicates a rich exhaust; a low signal indicates a lean exhaust. In normal operation, the oxygen sensor voltage ranges from 100 to 1000 mV. The sensor must be hot (above 500°F/260°C), and the system must be in closed loop before the PCM corrects the fuel mixture in response to the O2S signal.

The prefixes B1 and B2 correlate to the O2S for banks 1 and 2. Bank 1 is always the bank that contains number 1, or the first cylinder in the firing order. Suffix S1 indicates a pre-catalyst oxygen sensor, while suffix S2 indicates a post-catalyst sensor.

During closed loop operation, the sensor signals should range from 100 mV to 900 mV. A lean condition causes both sensors to read below 400 mV, while a rich condition causes readings above 600 mV. At 2500 RPM readings should switch between high and low at least six-to-ten times every ten seconds.

O2S11(V)**O2S12(V)****O2S13(V)****O2S14(V)****O2S21(V)****O2S22(V)****O2S23(V)****O2S24(V)****O2S32(V)****O2S41(V)****O2S42(V)**

Range: _____ **0.0 to 1.0**

Indicates the signal voltage for each oxygen sensor (O2S) on the vehicle. For example; O2S11 is the signal for bank 1 sensor 1 (upstream), and O2S12 is for bank 1 sensor 2 (downstream).

An O2S generates a voltage signal ranging from 0 to 1 volt or a little over 1 volt. A high signal (above 0.45V) indicates a rich condition; a low signal (below 0.45V) indicates a lean condition.

The O2S must be hot (above 500°F/260°C), and the system must be operating in closed loop before the PCM corrects the fuel mixture in response to the O2S signal.

O2S11(mA)

O2S12(mA)

O2S13(mA)

O2S14(mA)

O2S21(mA)

O2S22(mA)

O2S23(mA)

O2S24(mA)

O2S31(mA)

O2S32(mA)

O2S41(mA)

O2S42(mA)

Range: _____ **-128 to +128**

Indicates the current for each oxygen sensor (O2S) in milliampere (mA). For example, O2S11 shows the signal for bank 1 sensor 1 (upstream). O2S12 is the signal for bank 1 sensor 2 (downstream). The mA reading applies only to linear or wide-range sensors.

PTO STAT

Range: _____ **ON/OFF**

Indicates the operating status of the power take off (PTO). The reading is OFF when PTO is off, and ON when PTO is on.

RPM

Range: _____ **0 to engine max.**

Indicates the engine speed in revolutions per minute. The RPM value is computed internally by the PCM based on signals from the ignition system or a crankshaft sensor.

RUNTM(SEC)

Range: _____ **0 to 65535 seconds**

Indicates the engine running time since startup in seconds. The counter stops if the engine stalls. It resets when power is applied to the PCM or the ignition key cycles.

SHRTFT1(%)

SHRTFT2(%)

SHRTFT3(%)

SHRTFT4(%)

Range: _____ **-100 to +100%**

Indicates the operation and short-term correction of the fuel mixture on the vehicle with 0% as the midpoint. Values above zero indicate a short-term rich mixture correction command from the PCM, which increases fuel injector duration. Values below zero indicate a lean mixture command from the PCM, which decreases fuel injector duration.

The SHRTFT corrections lead the long-term trim (LONGFT) numbers. When a pattern or trend of short-term corrections to fuel-metering occur, the LONGFT parameters respond with a similar correction.

SHRTFT11(%)
SHRTFT12(%)
SHRTFT13(%)
SHRTFT14(%)
SHRTFT21(%)
SHRTFT22(%)
SHRTFT23(%)
SHRTFT24(%)
SHRTFT31(%)
SHRTFT32(%)
SHRTFT41(%)
SHRTFT42(%)

Range: _____ **-100 to +100%**

Indicates the short-term fuel trim for each oxygen sensor (O2S) used. For example, SHRTFT11 shows the signal for bank 1 sensor 1 (upstream) and SHRTFT12 is the signal for bank 1 sensor 2 (downstream). Displayed values represent the operation and short-term correction of the fuel mixture, with 0% as the midpoint. Values above zero indicate a rich mixture correction command from the PCM. Values below zero indicate a lean mixture command from the PCM.

SPARKADV(°)

Range: _____ **-64 to +63.5**

Indicates the ignition spark advance applied to cylinder #1 by the PCM. The PCM calculates the advance required based on input from various sensors. The displayed value is in addition to base timing. A positive value indicates the PCM is commanding timing advance, a negative value indicates the PCM is commanding timing retard.

ST TRIM B1(%)

ST TRIM B2(%)

ST TRIM(%)

Range: _____ **-20 to +20%**

Indicates the operation and short-term correction of fuel-metering. The ST TRIM number range from -20% to +20% with 000% as the midpoint. A number above zero percent indicates that the PCM has commanded a short-term rich mixture correction. A number below zero percent indicates the PCM is commanding a lean mixture.

The ST TRIM numbers lead the long-term trim (LT TRIM) numbers. When a pattern or trend of short-term corrections to fuel-metering occur, LT TRIM responds with a similar correction.

Compare ST TRIM to injector on-time. A number above zero indicates increased on-time, while those below zero indicate decreased on-time. LT TRIM corrections operate only in closed loop.

TAC PCT(%)

Range: _____ **0 to 100%**

Indicates the throttle actuator control (TAC) status as a percentage of total throttle opening. A reading of 0% indicates a fully closed throttle, and 100% indicates a wide open throttle.

THROTTLE(%)

Range: _____ **0 to 100%**

Indicates the PCM calculated throttle opening based on the throttle position (TP) sensor voltage. A reading of 0% indicates a fully closed throttle, and 100% indicates a wide open throttle. Closed-throttle readings vary because of the idle speed control (ISC) motor position and throttle body adjustments.

TP(%)**TP B(%)****TP C(%)**

Range: _____ **0 to 100%**

Indicates the PCM calculated absolute throttle position (TP) of the TP sensors. The display shows the sensor output signal in proportion to the input signal as a percentage.

TP R(%)

Range: _____ **0 to 100%**

Indicates the relative, or learned, position of the throttle position (TP) sensor. The display shows the PCM calculated TP based on adaptive strategy as a percentage.

TRIM B1-S1(%)**TRIM B2-S3(%)****TRIM B1-S4(%)****TRIM B2-S4(%)****TRIM B2-S1(%)****TRIM B1-S2(%)****TRIM B2-S2(%)****TRIM B1-S3(%)**

Range: _____ **-100 to +99.2%**

Indicates the operation and short-term correction of the fuel-metering based on oxygen sensor (O2S) signals. The TRIM numbers indicate whether the PCM is commanding a rich or a lean mixture in response to inputs from O2S B1-S1 and B2-S1.

Trim number prefixes B1 and B2 correlate to banks 1 and 2. Bank 1 is the bank that contains the number 1 cylinder. TRIM number suffix S1 indicates a pre-catalyst oxygen sensor input, while suffix S2 indicates a post-catalyst sensor input.

Values typically range from -20% to +20% with 000% as the midpoint. Any number above 0% indicates that the PCM commands a short-term rich mixture correction. A number below 0% indicates the PCM commands a lean mixture. During closed-loop operation, these numbers should closely follow ST TRIM B1 and ST TRIM B2. If N/A displays, the PCM is not supported.

VEH SPEED(MPH)**VEH SPEED(KPH)**

Range: _____ **0 to vehicle max.**

Indicates the PCM calculated vehicle speed based on the vehicle speed sensor (VSS) signal.

VPWR(V)

Range: _____ **variable**

Indicates the vehicle power (VPWR) applied to the ECM as voltage. Readings vary and do not always equal battery voltage.

VSS(KPH)**VSS(MPH)**

Range: _____ **0 to vehicle max.**

Indicates the vehicle speed. Readings are calculated by the PCM based on input from the vehicle speed sensor (VSS), or from input from other sensors.

WARM UPS

Range: _____ **0 to 255**

Shows the number of warm-up cycles since a DTC set. A valid warm-up cycle is when engine coolant temperature (ECT) is at least 40°F (22°C) at startup and reaches at least 160°F (70°C) for a gas engine, or 140°F (60°C) for a diesel engine. The value resets when DTCs are cleared.

Hybrid HV ECU and Battery System Parameters

+B VOLTS

Range: _____ Min.: 0 V, Max.: 65.535 V

Constant: Auxiliary battery voltage +/-3 V.

#CODES

Range: _____ Min.: 0, Max.: 127

Indicates the number of emission related powertrain DTCs.

A/C CONSMPT PWR (KW)

Range: _____ Min.: 0 kW, Max.: 5 Kw

Indicates the A/C consumption power.

AUX. BATT V

Range: _____ 0 to 25.4 V

Equivalent to auxiliary battery voltage

ACCEL DEG (%)

Range: _____ Min.: 0%, Max.: 100%

Indicates accelerator pedal depressed angle, accelerator pedal depressed: Changes with accelerator pedal pressure.

ACCEL POS1(%)

Range: _____ Min.: 0%, Max.: 100%

Indicates the Number 1 accelerator pedal position sensor. Changes as accelerator pedal moves.

ACCEL POS2(%)

Range: _____ Min.: 0%, Max.: 100%

Indicates the Number 2 accelerator pedal position sensor. Changes as accelerator pedal moves.

AMBIENT TEMP

Range: _____ Min.: -40°C, Max.: 215°C

Indicates the ambient air temperature with Power switch ON (IG): Same as ambient air temperature.

BATT INSIDE AIR

Range: _____ -327.68 C to 327.67 C

Indicates the temperature of ambient intake air to battery pack. Undisturbed for 1 day: Same as ambient air temperature.

BATTERY BLOCK MAX(V)

Range: _____ Min.: -327.68 V, Max.: 327.67 V

Indicates the battery block maximum voltage.

- SOC 55 to 60%: 23 V or less

BATTERY BLOCK MINIMUM(V)

Range: _____ Min.: -327.68 V, Max.: 327.67 V

Indicates the battery block minimum voltage.

- SOC 50 to 60%: 12 V or more

BATTERY BLOCK(V) V01 to V14

Range: _____ Min.: -327.68 V, Max.: 327.67 V

Indicates the battery block voltage.

- SOC 60%: 12 to 20 V

BATTERY SOC

Range: _____ 0% to 100%

Indicates the battery state of charge.

BATTERY TEMPERATURE 1 to 3

Range: _____ Min.: -327.68°C, Max.: 327.67°C

Indicates the temperature of the HV battery. Undisturbed for 1 day: Same as ambient air.

CHECK MODE

Range: _____ ON/OFF

Indicates the check mode.

CONVERTER TEMP

Range: _____ Min.: -50°C, Max.: 205°C

Indicates boost converter temperature.

- Undisturbed for 1 day at 25°C (77°F): 25°C (77°F)
- Street driving: 25 to 60°C (77 to 140°F)
- If the value is -50°C (-58°F): +B short in sensor circuit
- If the value is 205°C (401°F): Open or GND short in sensor circuit

COOLANT TEMP

Range: _____ Min.: -40°C, Max.: 140°C

Indicates the engine coolant temperature.

- After warming up: 80 to 100°C (176 to 212°F)
- If the value is -40°C (-40°F): Open in sensor circuit
- If the value is 140°C (284°F): Short in sensor circuit

COOLING FAN SPD

Range: _____ Min.: 0, Max.: 6

Indicates the battery blower motor actuation mode.

- Stopped: 0
- Low to High speed actuation: 1 to 6

CURRENT DTC

Range: _____ Min.: 0, Max.: 255

Indicates the number of current DTCs.

DELTA SOC

Range: _____ 0% to 100%

Indicates the difference between maximum and minimum values of SOC. READY light ON, engine stopped, and no electrical load: 0 to 60%.

DISCHARGE RQST SOC (W)

Range: _____ Min.: -20,480 W, Max.: 20,320 W

Indicates discharge request to adjust SOC.

- Uniform on-board charging: -4,400 W
- Usually: 0 W

DIST DTC CLEAR

Range: _____ Min.: 0 km, Max.: 65,535 km

Indicates the drive distance after clearing DTCs.

DTC

Range: _____ Min.: 0, Max.: 255

Indicates the number of stored DTCs.

DRIVE CONDITION

Range: _____ MG1/MG2

Indicates the driving condition.

- MG1 load: MG1
- MG2 load: MG2

DRIVE CONDITION ID

Range: _____ Min.: 0, Max.: 6

Indicates the drive condition ID.

- Engine stopped: 0
- Engine about to be stopped: 1
- Engine about to be started: 2
- Engine operated or operating: 3
- Generating or loading movement: 4
- ????: 6
- Revving up with P position: 6

DRIVING MILEAGE

Range: _____ 0 km to 65,535 km

Indicates the accumulated driving mileage after the malfunction occurrence.

ECU CTRL MODE

Range: _____ Min.: 0, Max.: 4

Indicates the ECU control mode.

ECU TYPE

Range: _____ HV ECU/EV ECU

Indicates the type of ECU.

ENG RUN TIME

Range: _____ Min.: 0 s, Max.: 65,535 s

Indicates the elapsed time after starting engine that key cycle.

ENG STOP RQST

Range: _____ NO/YES

Indicates the engine stop request.

- Requesting stop: YES

ENG WARM UP RQST

Range: _____ NO/YES

Indicates the engine warm-up request.

- Requesting engine warm-up: YES

ENGINE SPD (RPM)

Range: _____ Min.: 0 rpm, Max.: 8,000 rpm

Idling*: 950 to 1,050 rpm.

HISTORY DTC

Range: _____ Min.: 0, Max.: 255

Indicates the number of history DTCs.

HV BATT CH RQST

Range: _____ NO/YES

Indicates the HV battery charging request.

- Requesting HV battery charging: YES

IB BATTERY

Range: _____ -327.68 A to 327.67 A

Indicates the current value of the battery pack:

- Soon after a full-load acceleration with the engine stopped: Maximum 140 A (room temperature)
- When shifting into N position, 1 second has elapsed after engine started with P position, engine stopped, head light ON, A/C fan high, and READY light ON: Maximum 30 A.

IDLING REQUEST

Range: _____ NO/YES

Indicates the engine idling request.

- Requesting idle: YES

INTAKE AIR

Range: _____ Min.: -40°C, Max.: 140°C

Indicates the intake air temperature. Constant: Same as ambient air temperature.

INTERNAL RESISTANCE(OHMS) R01-R14

Range: _____ Min.: 0 ?, Max.: 0.255 ?

Indicates the internal resistance of each battery block. Always: 0.01 to 0.1 ?

MAX BAT BLOCK #

Range: _____ 0 to 13

Indicates the battery block number with maximum voltage, one of the numbers 0 to 13.

MG1 INVERT TEMP

Range: _____ Min.: -50°C, Max.: 205°C

Indicates MG1 inverter temperature.

- Undisturbed for 1 day at 25°C (77°F): 25°C (77°F)
- Street driving: 25 to 80°C (77 to 176°F)
- If the value is -50°C (-58°F): +B short in sensor circuit
- If the value is 205°C (401°F): Open or GND short in sensor circuit

MG1 REV (RPM)

Range: _____ Min.: -16,383 rpm, Max.: 16,383 rpm

Indicates MG1 revolutions, in RPM.

MG1 TORQ (N-m)

Range: _____ Min.: -500 Nm, Max.: 500 Nm

Indicates MG1 torque, in Newton Meters.

MG1 TORQ EXEC VAL (N-m)

Range: _____ Min.: -512 Nm, Max.: 508 Nm

Indicates MG1 torque execution value when 1 second has elapsed after the engine was started automatically with READY light ON, engine stopped, A/C fan Hi, headlight ON and the P position: Less than +/-20% of MG1 TORQ.

MG2 INVERT TEMP

Range: _____ Min.: -50°C, Max.: 205°C

Indicates MG2 inverter temperature.

- Undisturbed for 1 day at 25°C (77°F): 25°C (77°F)
- Street driving: 25 to 80°C (77 to 176°F)
- If the value is -50°C (-58°F): +B short in sensor circuit
- If the value is 205°C (401°F): Open or GND short in sensor circuit

MG2 REV (RPM)

Range: _____ Min.: -16,383 rpm, Max.: 16,383 rpm

Indicates MG2 revolutions, in RPM.

MG2 TORQ (N-m)

Range: _____ Min.: -500 Nm, Max.: 500 Nm

Indicates MG2 torque, in Newton Meters.

MG2 TORQ EXEC VAL (N-m)

Range: _____ Min.: -512 Nm, Max.: 508 Nm

Indicates MG2 torque execution value after full-load acceleration with READY light ON and engine stopped: Less than +/-20% of MG2 TORQ.

MIL ON RUN DIST

Range: _____ Min.: 0 km, Max.: 65,535 km

Indicates the drive distance after malfunction occurrence.

MIL ON RUN TIME

Range: _____ Min.: 0 min, Max.: 65,535 min

Indicates the elapsed time after starting engine with MIL ON.

MIL STATUS**MIL Status****MIL status**

Range: _____ ON/OFF

Indicates the malfunction indicator lamp (MIL) status.

- Constant ON: repair in accordance with detected DTCs

MIN BAT BLOCK #

Range: _____ 0 to 13

Indicates the battery block number with minimum voltage, one of the numbers 0 to 13.

M SHIFT SENSOR (V)

Range: _____ Min.: 0 V, Max.: 5 V

Indicates the output voltage of the shift position sensor (main).

- Selector lever in home position: 2.0 to 3.0 V
- Shifting into R position: 4.0 to 4.8 V
- Shifting into B or D position: 0.2 to 1.0 V

MCYL CTRL POWER (N-m)

Range: _____ Min.: -512 Nm, Max.: 508 Nm

Indicates braking torque that is equivalent to the master cylinder hydraulic pressure. Brake pedal depressed: Changes with brake pedal pressure.

MOTOR1 TEMP

Range: _____ Min.: -50°C, Max.: 205°C

Indicates MG2 motor temperature.

- Undisturbed for 1 day at 25°C (77°F): 25°C (77°F)
- Street driving: 25 to 80°C (77 to 176°F)
- If the value is -50°C (-58°F): Open or +B short in sensor circuit
- If the value is 205°C (401°F): GND short in sensor circuit

MOTOR2 TEMP

Range: _____ Min.: -50°C, Max.: 205°C

Indicates transaxle fluid temperature.

- Undisturbed for 1 day at 25°C (77°F): 25°C (77°F)
- Street driving: 25 to 80°C (77 to 176°F)
- If the value is -50°C (-58°F): Open or +B short in sensor circuit
- If the value is 205°C (401°F): GND short in sensor circuit

NUMBER OF BATT BLOCK

Range: _____ Min.: 0, Max.: 255

Indicates the number of battery blocks, always: 14.

OBD CERT

Range: _____ ???-OBD2

Indicates compliance regulation OBD2 (CARB).

POWER RQST (W)

Range: _____ Min.: 0 W, Max.: 320,000 W

Indicates the engine power output request value in Watts.

PWR RESOURCE VB (V)

Range: _____ Min.: 0 V, Max.: 510 V

Indicates the HV battery voltage. READY light ON and P position: 150 to 300 V.

PWR RESOURCE IB (AMP)

Range: _____ Min.: -256 A, Max.: 254 A

Indicates the HV battery current.

RAISING PRES RATIO (%)

Range: _____ Min.: 0%, Max.: 100%

Indicates the boost ratio, the pre-boost voltage and post-boost voltage are equal: 0 to 10%.

REGEN EXEC TORQ (N-m)

Range: _____ Min.: 0 Nm, Max.: 186 Nm

Indicates regenerative brake execution torque.

REGEN REQUEST TORQ (N-m)

Range: _____ Min.: 0 Nm, Max.: 186 Nm

Indicates regenerative brake request torque. Vehicle speed 30 km/h (19 mph) and master cylinder hydraulic pressure -200 Nm: Changes with brake pedal pressure.

S SHIFT SENSOR (V)

Range: _____ Min.: 0 V, Max.: 5 V

Indicates the output voltage of the shift position sensor (sub).

- Selector lever in home position: 2.0 to 3.0 V
- Shifting into R position: 4.0 to 4.8 V
- Shifting into B or D position: 0.2 to 1.0 V

SBLW RQST

Range: _____ ON/OFF

Indicates the battery blower motor stop control request (standby blower).

SHIFT POSITION

Range: _____ P, R, N, D or B

Indicates the shift position: P, R, N, D or B.

SHORT WAVE HIGH

Range: _____ Min.: 0 V, Max.: 5 V

Indicates the waveform voltage in leak detection circuit in battery ECU.

- READY light is left ON for 2 minutes, and the pre-boost voltage and the post-boost voltage are equal: 4 V or more

SM SHIFT SENSOR (V)

Range: _____ Min.: 0 V, Max.: 5 V

Indicates the output voltage of the select position sensor (main).

- Selector lever in home position: 0.5 to 2.0 V
- Shifting into R, N or D position: 3.0 to 4.85 V

SOC (%)

Range: _____ Min.: 0%, Max.: 100%

Indicates the battery state of charge. Constant: 0 to 100%.

SS SHIFT SENSOR (V)

Range: _____ Min.: 0 V, Max.: 5 V

Indicates the output voltage of the select position sensor (sub).

- Selector lever in home position: 0.5 to 2.0 V
- Shifting into R, N or D position: 3.0 to 4.85 V

SS SHIFT SENSOR (V)

Range: _____ Min.: 0 V, Max.: 5 V

Indicates the output voltage of the select position sensor (sub).

- Selector lever in home position: 0.5 to 2.0 V
- Shifting into R, N or D position: 3.0 to 4.85 V

TARGET ENG SPD (RPM)

Range: _____ Min.: 0 rpm, Max.: 8,000 rpm

Indicates the target engine speed.

TIME DTC CLEAR(MIN)

Range: _____ Min.: 0 min, Max.: 65,535 min

Indicates the elapsed time after clearing DTCs.

VEHICLE SPD

Range: _____ Min.: 0 km/h, Max.: 255 km/h

Indicates the vehicle speed.

- Vehicle stopped: 0 km/h (0 mph)

VEHICLE SPD

Range: _____ Min.: -256 km/h, Max.: 254 km/h

Indicates resolver vehicle speed. Driving at 40 km/h (25 mph): 40 km/h (25 mph).

VH (V)

Range: _____ Min.: 0 V, Max.: 765 V

Indicates high voltage after it is boosted. Engine revved up with the transmission in Park position: HV battery voltage to 500 V.

- If the value is 0 V: Open or GND short in sensor circuit
- If the value is 765 V: +B short in sensor circuit

VL (V)

Range: _____ Min.: 0 V, Max.: 510 V

Indicates high voltage before it is boosted. Power switch ON (READY): Practically the same as the HV battery voltage.

- If the value is 0 V: Open or GND short in sensor circuit
- If the value is 510 V: +B short in sensor circuit

VMF FAN VOLTAGE

Range: _____ Min.: -25.6 V, Max.: 25.4 V

Indicates the battery blower motor monitoring voltage.

- Fan mode 1 with READY light ON and P position: 9.5 to 11.5 V

WARM UPS CYC DTC CLEAR

Range: _____ Min.: 0, Max.: 255

Indicates the number of times engine is warmed up after clearing DTCs. One cycle, MIL OFF, engine coolant temperature increases from below 22°C (71.6°F) before starting the engine to above 70°C (158°F) after starting the engine. Increments once per warm up cycle.

WIN

Range: _____ Min.: -64 kW, Max.: 0 kW -25 kW or more

Indicates the charge control wattage sent from battery ECU to the hybrid vehicle control ECU.

WIN CTRL POWER (W)

Range: _____ Min.: -40,800 W, Max.: 0 W

Indicates the charge control power value. Normal is -25,000 W or more.

WOUT

Range: _____ Min.: 0 kW, Max.: 63.5 Kw

Indicates the discharge control wattage which is sent from battery ECU to hybrid vehicle control ECU, 21 kW or less.

WOUT CTRL POWER (W)

Range: _____ Min.: 0 W, Max.: 81,600 W

Indicates the discharge control power value. Normal is 21,000 W or less.

OBD-II Readiness Monitors

This section defines generic OBD-II readiness monitor parameters. To find the description of a specific parameter, locate the parameter name in the index and then go to the listed page.

A/C REFRIG

Range: _____ **READY/NOT DONE/N/A**

No description available.

AIR

Range: _____ **READY/NOT DONE/N/A**

Indicates and monitors the function of the secondary air system, and tests the ability of the AIR system to inject air into the exhaust. This monitor relies on O2S feedback to determine the presence of air flow. Inputs from the ECT, IAT, and CKP sensors, and the O2S monitor are required to enable the AIR monitor.

CAT

Range: _____ **READY/NOT DONE/N/A**

Indicates when the catalytic converter has fallen below a minimum level of effectiveness. Inputs from the ECT, IAT, and TP sensors are required to enable this monitor. Some vehicles may also require CKP and VSS inputs. When this monitor is READY, it relies mainly on inputs from the oxygen sensors.

COMPONENTS

Range: _____ **READY/NOT DONE/N/A**

Indicates when a malfunction occurs in any PCM input or output circuit that is not exclusively monitored by another monitor system. A malfunction can be a short, an open, or an out-of-range value. This monitor is enabled shortly after the engine is started. However, some individual components may not immediately be available for monitoring.

EGR SYS

Range: _____ **READY/NOT DONE/N/A**

Indicates the EGR system. Tests the integrity and flow characteristics of the EGR system. This monitor is enabled during EGR system operation, after certain base engine operating conditions are satisfied. Inputs from the ECT, IAT, TP, and CKP sensors are required to enable the EGR monitor.

EVAP SYS

Range: _____ **READY/NOT DONE/N/A**

Indicates the EVAP system. Checks the function of EVAP components and the ability of the system to flow fuel vapor (hydrocarbons) to the engine. The sequence of events required to enable this monitor vary, depending on the EVAP system components.

FUEL SYS

Range: _____ **READY/NOT DONE/N/A**

Indicates and monitors the adaptive fuel control system and determines when a learned value exceeds a specified threshold. Inputs from the ECT, IAT, and MAF or MAP sensors are required to enable this monitor.

HEATED CAT

Range: _____ **READY/NOT DONE/N/A**

No description available.

MISFIRE**Range:** _____ **READY/NOT DONE/N/A**

Indicates and monitors engine misfire and designates by DTC the specific cylinder in which a misfire occurs. Misfire is a lack of combustion. Which may be due to an absence of spark, poor fuel metering, poor compression, or any other cause. Typically, inputs from the ECT, MAF, and CKP sensors are required to enable this monitor.

O2 SENSOR**Range:** _____ **READY/NOT DONE/N/A**

Indicates and monitors oxygen sensor switching frequency for degradation and circuit operation.

O2 HEATER**Range:** _____ **READY/NOT DONE/N/A**

Indicates and monitors the oxygen sensor heater circuit for proper operation when heated oxygen sensors are used.

Occupant Classification (OCC) Parameters

This section defines parameters available from the airbag or supplemental restraint system Occupant Classification (OCC) systems. To find the description of a specific parameter, locate the parameter name in the index and then go to the listed page.

PASSENGER CLASS

Range: _____ OFF/CRS/CHILD/AF05/AM50

Indicates the passenger classification weight based measurement.

- If the value is CRS: child restraint system is active
- If the value is CHILD: under 80 lbs
- If the value is AF05: 80 lbs to 120 lbs
- If the value is AM50: above 120 lbs

SENS RANGE INF

Range: _____ OK/NG

Indicates the status of the sensor range information.

FL SENS RANGE

FR SENS RANGE

RL SENS RANGE

RR SENS RANGE

Range: _____ OK/MAX/MIN

Indicates the relative weight input to seat sensor.

- OK sensor range is -38 lbs to +60 lbs
- MAX is above +60 lbs
- MIN is lower than -38 lbs

FL SENS VOLTS

FR SENS VOLTS

RL SENS VOLTS

RR SENS VOLTS

Range: _____ 0 V to 19.8 V

Indicates the sensor volts. Normal range is 0 V to 4.7 V.

FL SENS WEIGHT(lbs)

FR SENS WEIGHT(lbs)

RL SENS WEIGHT(lbs)

RR SENS WEIGHT(lbs)

Range: _____ -38(lbs) to +82(lbs)

Indicates the relative weight input to seat sensor. Normal range is -38 lbs to +82 lbs.

TOTAL WEIGHT(lbs)

Range: _____ -150(lbs) to +283(lbs)

Indicates the relative weight input to seat sensor. Normal range is -150 lbs to +283 lbs.

D BUCKLE SW

Range: _____ ON/OFF/NG

Indicates the driver buckle switch status.

P BUCKLE SW

Range: _____ ON/OFF/NG

Indicates the passenger buckle switch status.

Instrument Panel Cluster (IPC) Parameters

This section defines data parameters available from the instrument panel cluster (IPC) assemblies that have the ability to communicate with a scan tool via the DLC connector. To find the description of a specific parameter, locate the parameter name in the index and then go to the listed page.

ABS LAMP

Range: _____ OFF/ON

Indicates the state of the antilock brake system (ABS) indicator lamp as commanded by the instrument panel cluster (IPC).

ABS_WARN

Range: _____ OFF/ON

Antilock brake system (ABS) indicator lamp warning.

AIR BAG LAMP

Range: _____ OFF/ON

Indicates the state of the airbag system or supplemental inflatable restraint system (SIR) indicator lamp as commanded by the instrument panel cluster (IPC).

BATTERY LAMP

Range: _____ OFF/ON

Indicates the state of the battery indicator/charging system lamp as commanded by the instrument panel cluster (IPC).

BATTERY VOLTS

Range: _____ 0.00 to 19.0

Indicates the voltage measured at the battery positive voltage circuit of the instrument panel cluster (IPC).

BRAKE LAMP

Range: _____ OFF/ON

Indicates the state of the brake system indicator lamp as commanded by the instrument panel cluster (IPC). This lamp will also illuminate indicating that the parking brake is applied.

BRAKE_WARN

Range: _____ OFF/ON

Brake system warning.

CHECK GAUGES LAMP

Range: _____ OFF/ON

Indicates the state of the cruise control system indicator lamp as commanded by the instrument panel cluster (IPC).

CCNT

Range: _____ actual

Diagnostic trouble code count.

CRUISE CONTROL

Range: _____ OFF/ON

Indicates the state of the cruise control system indicator lamp as commanded by the instrument panel cluster (IPC).

DIC FUEL INFO SWITCH

Range: _____ OFF/ON

Indicates the state of the fuel button of the driver information center (DIC) switch as monitored by the instrument panel cluster. A closed switch is displayed as ON.

DIC PERSONALIZATION SW

Range: _____ OFF/ON

Indicates the state of the personalization button of the driver information center (DIC) switch as monitored by the instrument panel cluster (IPC). A closed switch is displayed as ON.

DIC SELECT SWITCH

Range: _____ OFF/ON

Indicates the state of the select button of the driver information center (DIC) switch as monitored by the instrument panel cluster (IPC). A closed switch is displayed as ON.

DIC TRIP INFO SWITCH

Range: _____ OFF/ON

Indicates the state of the trip information button of the driver information center (DIC) switch as monitored by the instrument panel cluster (IPC). A closed switch is displayed as ON.

DISPLAY COOLANT TEMP

Range: _____ 100 to 260°F or 38 to 128°C

Indicates the displayed coolant temperature gauge value in the instrument panel cluster (IPC). This value may differ slightly from the monitored coolant temperature.

DISPLAYED FUEL LEVEL (%)

Range: _____ 0 to 100%

Indicates the displayed fuel level gauge value in the instrument panel cluster (IPC). This value may differ slightly from the monitored fuel level.

DISPLAYED ODOMETER

Range: _____ 0 to 999999 MI or 0 to 999999 KM

Indicates the displayed odometer value in the instrument panel cluster (IPC).

DR_BUKL

Range: _____ BUCKLED/UNBUCKLED

Indicates the status of the driver's seat belt buckle.

DISPLAYED OIL PRESSURE

Range: _____ 0 to 99 psi or 0 to 682 kPa

Indicates the displayed oil pressure gauge value in the instrument panel cluster (IPC). This value may differ slightly from the monitored oil pressure.

DRAJLMP_IC

Range: _____ OFF/ON

Driver door ajar lamp status.

DRIV_DR

Range: _____ OFF/ON

Driver door ajar switch status.

ENGINE RPMRange: _____ **0 to 9999**

Indicates engine RPM. The powertrain control module (PCM) computes the engine RPM. The instrument panel cluster (IPC) monitors the engine RPM circuit from the PCM. Engine RPM should remain close to the desired idle under various engine loads with the engine idling.

Fuel Gauge**FUEL_LEVEL(%)**Range: _____ **0 to 100%**

Indicates the amount of fuel in the tank as a percentage.

GATE or CARGO DOOR AJARRange: _____ **OFF/ON**

Indicates the state of the lift gate switch as monitored by the instrument panel cluster (IPC). When the lift gate or cargo door is opened, the lift-gate switch closes. A closed switch is displayed as ON.

HD_LMP_SWRange: _____ **OFF/ON**

Head lamp switch.

HIGH BEAM LAMPRange: _____ **OFF/ON**

Indicates the state of the headlamp high beam indicator lamp as commanded by the instrument panel cluster (IPC).

IGN. CYCLES SINCE LAST DTCRange: _____ **0 to 50**

Indicates 0 to 50. The IPC counts the number of times the ignition is cycled since the current DTC was set.

IGN_KEYRange: _____ **IN/OUT**

Indicates ignition key.

IGNITION 1 (V)Range: _____ **0.00 to 19.0**

Indicates voltage measured on the ignition 1 voltage circuit of the instrument panel cluster (IPC).

INST_VBATRange: _____ **0 to 16 V**

Instrument cluster module voltage.

LEFT TURN SIGNALRange: _____ **OFF/ON**

Indicates the left turn signal supply voltage circuit as monitored by the instrument panel cluster (IPC). An active turn signal will toggle the parameter between OFF and ON.

Light RheostatRange: _____ **0 to 255**

Indicates the position of the lighting control rheostat.

LOW FUEL LAMPRange: _____ **OFF/ON**

Indicates the state of the low fuel warning indicator lamp as commanded by the instrument panel cluster (IPC).

LOW WASHER FLUIDRange: _____ **OPEN/CLSD**

Indicates the state of the low washer fluid switch input as monitored by the instrument panel cluster (IPC). A closed switch indicates the fluid level is low and is displayed as CLSD.

MONITORED COOLANT TEMPRange: _____ **40 to 419°F or 40 to 215°C**

Indicates the instrument panel cluster (IPC) monitored coolant temperature data as provided by the PCM via serial data communication. This value may differ slightly from the displayed coolant temperature.

MONITORED FUEL LEVEL (%)Range: _____ **0 to 100%**

Indicates the instrument panel cluster (IPC) monitored fuel level as provided by the PCM via serial data communication. This value may differ slightly from the displayed fuel level.

MONITORED OIL PRESSURERange: _____ **0 to 99 psi or 0 to 682 kPa**

Indicates the instrument panel cluster (IPC) monitored oil pressure as provided by the PCM via serial data communication. This value may differ slightly from the displayed oil pressure.

ODOMETRRange: _____ **actual**

Indicates the odometer reading.

Odo/Trip SwRange: _____ **ON/OFF**

Indicates the status of the odometer trip switch.

OIL_P_L_ICRange: _____ **OFF/ON**

Oil pressure low indicator status.

P_DRRange: _____ **CLSD/AJAR**

Passenger door status.

PRNDL DISPLAYRange: _____ **PARK, REVERSE, NEUTRAL, DRIVE, 3RD, 2ND, 1ST, INVALID**

Indicates the state of the PRNDL switch as commanded by the instrument panel cluster (IPC). INVALID indicates an invalid value.

PRNDL STATERange: _____ **INV, PARK, REV, NEUT, DRV, 3RD, 2ND, 1ST, INV**

Indicates the state of the PRNDL switch as commanded by the instrument panel cluster (IPC). INV indicates an invalid value.

RIGHT TURN SIGNALRange: _____ **OFF/ON**

Indicates the right turn signal supply voltage circuit as monitored by the instrument panel cluster (IPC). An active turn signal will toggle the parameter between OFF and ON.

SBLTLMPC_IC**SEAT BELT LAMP**Range: _____ **OFF/ON**

Indicates the state of the seat belt/fasten seat belt indicator lamp as commanded by the instrument panel cluster (IPC).

SECURITY LAMPRange: _____ **OFF/ON**

Indicates the state of the security system indicator lamp as commanded by the instrument panel cluster (IPC).

SELTESTDTCRange: _____ **actual**

Indicates the number of trouble codes set due to diagnostic test.

SERVICE 4WDRange: _____ **OFF/ON**

Indicates the state of the serviced 4WD system indicator lamp as commanded by the instrument panel cluster (IPC).

Speed MeterRange: _____ **0 to 158 MPH or 0 to 255 KPH**

Indicates the vehicle speed. The display should match the reading on the speedometer.

Tacho MeterRange: _____ **0 to 12,750 RPM**

Indicates the engine speed. The display should match the tachometer reading, if equipped.

Tail CancelRange: _____ **ON/OFF**

Indicates the status of the cancel link between the tail lamps and the dimming rheostat.

TRIP_SWRange: _____ **actual**

Trip/odometer switch.

TRIP ODOMETER ARange: _____ **MI/KM**

Indicates trip odometer A. The instrument panel cluster (IPC) calculates trip odometer A information from the vehicle speed data received from the PCM.

TRIP ODOMETER BRange: _____ **MI/KM**

Indicates trip odometer B. The instrument panel cluster (IPC) calculates trip odometer B information from the vehicle speed data received from the PCM.

TRIP RESET SWITCHRange: _____ **INACTIVE/ACTIVE**

Indicates the state of the trip reset button of the driver information center (DIC) switch as monitored by the instrument panel cluster (IPC). A closed switch is displayed as ACTIVE.

UPSHIFT LAMP**Range:** _____ **OFF/ON**

Indicates the state of the upshift indicator lamp as commanded by the instrument panel cluster (IPC). This parameter may not be valid if the vehicle is equipped with an automatic transmission.

VEHICLE SPEED**Range:** _____ **0 to 155 MPH or 0 to 255 KPH**

Indicates the vehicle speed sensor. The powertrain control module (PCM) monitors the voltage at the signal circuit of the vehicle speed sensor. The voltage is proportional to the vehicle speed, The PCM computes the vehicle speed. The instrument panel cluster (IPC) monitors the vehicle speed signal circuit from the PCM.

Tire Pressure Monitor Parameters

This section defines data parameters that are available from the tire pressure monitor electronic control module (ECM). This section applies only to models with a stand alone tire pressure monitor ECM. Parameters for systems incorporated into the body control module (BCM) are defined in the BCM section.

2nd Tire

Range: _____ see below

Indicates the number of second tire identifications to be registered. Possible readings are: INV (invalid), 4, or 5.

Batt Volt 1

Batt Volt 2

Batt Volt 3

Batt Volt 4

Batt Volt 5

Range: _____ OVER/LESS

Indicates the status, either over or less than battery voltage, of the voltage signal for each of the monitored tires.

Ini Threshold 1(gauge)

Ini Threshold 2(gauge)

Ini Threshold 3(gauge)

Ini Threshold 4(gauge)

Ini Threshold 5(gauge)

Range: _____ 0 to 637.5 kPa or 0 to 92.2 psi

Indicates the initial threshold of low-pressure for each of the monitored tires.

Initial Switch

Range: _____ ON/OFF

Indicates the on/off status of the initialization switch.

Initial Switch Info

Range: _____ WITH/WITHOUT

Indicates the initialization switch setting information.

Main Tire

Range: _____ see below

Indicates the number of main tire identifications to be registered. Possible readings are: INV (invalid), 4, or 5.

Mode Status

Range: _____ NORM/TEST

Indicates the tire pressure warning mode status.

Regit ID 1 Code

Regit ID 2 Code

Regit ID 3 Code

Regit ID 4 Code

Regit ID 5 Code

Range: _____ 0 to 9 and A to F

Indicates the register identification for each of the monitored tires.

Select Switch

Range: _____ MAIN/2ND

Indicates the status of the initialization switch.

Select Switch Info

Range: _____ WITH/WITHOUT

Indicates the select switch setting information.

Tire Press 1(gauge)**Tire Press 2(gauge)****Tire Press 3(gauge)****Tire Press 4(gauge)****Tire Press 5(gauge)**

Range: _____ 0 to 637.5 kPa or 0 to 92.9 psi

Indicates the inflation pressure for each of the monitored tires.

Tire Temp 1**Tire Temp 2****Tire Temp 3****Tire Temp 4****Tire Temp 5**

Range: _____ -40 to 215°C or -40 to 419°F

Indicates the temperature for each of the monitored tires.

Trans Status

Range: _____ FINISH/NOW

Displays the status of the transmission identification code.

Transfer Case Parameters

This section provides parameter descriptions for electronic transfer cases on four-wheel drive (4WD) and all-wheel drive (AWD) vehicles. To find the description of a specific parameter, locate the parameter name in the index and then go to the listed page.

2WD HIGH LAMP

Range: _____ ON/OFF

Indicates the transfer case shift control module command status to the 2WD high indicator lamp on the instrument panel.

4WDHIGLMP_4X4M

Range: _____ OFF,OFF-FAIL,ON,ON-B+

Indicates the high indicator lamp.

4WD HIGH LAMP

Range: _____ ON/OFF

Indicates the transfer case shift control module command status to the 4WD high indicator lamp on the instrument panel.

4WDINP_SW_4X4M

Range: _____ OFF,OFF-FAIL,ON,ON-B+

Indicates the 4WD switch status.

4WD LOW ACTV

Range: _____ YES/NO

Indicates whether 4WD LOW is the current commanded mode in which the automatic transfer case (ATC) is operating.

4WD LOW LAMP

Range: _____ ON/OFF

Indicates the transfer case shift control module command status to the 4WD low indicator lamp on the instrument panel.

4WDLOWLMP_4X4M

Range: _____ OFF,OFF-FAIL,ON,ON-B+

Indicates the four-wheel drive LOW warning indicator.

ATC SLIP (RPM) SLIPPAGE (RPM)

Range: _____ ON/OFF

Indicates whether slip has been detected by the transfer case shift control module.

AUTO 4WD LAMP

Range: _____ ON/OFF

Indicates the transfer case shift control module command status to the Auto 4WD indicator lamp on the instrument panel.

BOO

Range: _____ ON/OFF

Indicates the brake ON/OFF.

COPENPLAT_4X4M

Range: _____ ERROR,A,B,AB,C,AC,BC,ABC,D,AD,BD,ABD,CD,ACD,BCD,ABCD

Indicates the currently open contact plates.

CUR SLIP ADAPTS

Range: _____ 0 to 65,025

No information is currently available for this parameter.

ENCODER GEAR

Range: _____ see below

Indicates the mode the transfer case is currently operating in, readings are:

- INVLD, invalid signal
- NEUT, neutral
- 2WD, two-wheel drive
- 4WD-L, four-wheel drive low
- 4WD-H, four-wheel drive high
- AUTO-4, automatic four-wheel drive
- 2WD-L, two-wheel drive low

ENCODER RETURN VOLTAGE

Range: _____ 0.0 to 7.5 V

Indicates the feedback voltage measured by the transfer case shift control module at the encoder signal return.

ENCODER SUPPLY VOLTAGE

Range: _____ 0.0 to 7.5 V

Indicates the voltage supplied to the transfer case shift control module.

F AXLE REQ

Range: _____ ON/OFF

Indicates the front axle switch request from the transfer case shift control module.

F AXLE SW LCKD

Range: _____ YES/NO

Indicates the state of the front axle switch. It reads YES if the switch is in the locked position to enabled 4WD operation.

F PROSHAFT (RPM)**R PROSHAFT (RPM)**

Range: _____ 0 to 8192 RPM

Indicates the speed of the front or rear propshaft as calculated by the transfer case shift control module.

IGN CYCLE DTC

Range: _____ actual count

Indicates how many ignition cycles have occurred since the last current DTC set.

LOW_LAMP

Range: _____ ON/OFF

Indicates the 4WD low indicator status.

MODE SW SELECTED

Range: _____ see below

Indicates the current position of the transfer case shift control switch, readings are:

- INVLD, invalid signal
- NEUT, neutral

- 2WD, two-wheel drive
- 4WD-L, four-wheel drive low
- 4WD-H, four-wheel drive high
- AUTO-4, automatic four-wheel drive
- 2WD-L, two-wheel drive low

MODE SW RETURN VOLTAGE

Range: _____ 0.0 to 5.0 V

Indicates the feedback signal (return voltage) from the transfer case shift control switch.

MOTOR A (mA)**MOTOR B (mA)**

Range: _____ variable

Indicates the current applied to the transfer case motors (A or B) in milliamperes. Readings are positive when the motors are driven forward, and negative (-) when driven in reverse.

MTR_CCW

Range: _____ ON/OFF

Indicates the counterclockwise shift motor driver output state.

MTR_CW

Range: _____ ON/OFF

Indicates the clockwise shift motor driver output state.

NEUT LIGHT

Range: _____ ON/OFF

Indicates the transfer case shift control module command status to the Neutral indicator lamp on the instrument panel.

NSAFETYSW_4X4M

Range: _____ ON/OFF

Indicates the neutral safety switch.

PLATE_A

Range: _____ ON/OFF

Indicates the transfer case contact plate switch A.

PLATE_B

Range: _____ ON/OFF

Indicates the transfer case contact plate switch B.

PLATE_C

Range: _____ ON/OFF

Indicates the transfer case contact plate switch C.

PLATE_D

Range: _____ ON/OFF

Indicates the transfer case contact plate switch D.

PLATE_PWR

Range: _____ OFF, OFF-FAIL, ON, ON-B+

Indicates the contact plate power.

SHMOTCCLO_4X4M

Range: _____ OFF, OFF-FAIL, ON, ON-B+

Indicates the transmission transfer counterclockwise motor output.

SHMOTCLOC_4X4M

Range: _____ OFF, OFF-FAIL, ON, ON-B+

Indicates the clockwise shift relay coil status.

SLIP ADPT DC (%)

Range: _____ 0 to 100%

Indicates the duty cycle of the signal being applied to the automatic transfer case motor.

SOFTWARE ID

Range: _____ YES/NO

Indicates whether the current calibration ID number is valid.

SVC 4WD LAMP

Range: _____ ON/OFF

Indicates the transfer case shift control module command status to the Service 4WD indicator lamp on the instrument panel.

VBATT

Range: _____ 0 to 16 V

Indicates battery positive voltage.

VSS_4X4M

Range: _____ 0 to vehicle max

Indicates vehicle speed.

XFER CASE LCKD

Range: _____ YES/NO

Indicates the state of the transfer case. It reads YES when locked to enabled 4WD operation.

Transmission Parameters

This section defines transmission data parameters available from the powertrain control module (PCM) or the transmission control module (TCM). To find the description of a specific parameter, locate the parameter name in the index and then go to the listed page.



NOTE:

Many transmissions are not the same from vehicle to vehicle, and some gear switch signals may not be active. A parameter for an inactive signal always reads ON or YES on the tool.

1 INDICATOR

Range: _____ ON/OFF

Indicates the status of the 1 indicator lamp on the instrument panel. It should only read ON when the 1 position lamp is lighted.

1 POS SWITCH

Range: _____ ON/OFF

Indicates whether the contacts to the 1st gear position switch are closed or open. Reads ON when the switch contacts are closed and the vehicle is in 1st gear.

1-2 ERROR(SEC)

2-3 ERROR(SEC)

3-4 ERROR(SEC)

Range: _____ variable

Indicates the difference between the desired shift time and the actual shift time. A positive number indicates a firm or fast shift, where the actual shift time was shorter than the desired shift time. A negative number indicates a soft or slow shift, where the actual shift time was longer than the desired shift time. This value is only accurate if the shift was adaptable.

1-2 SHIFT (SEC)

2-3 SHIFT (SEC)

3-4 SHIFT (SEC)

Range: _____ variable

Indicates the actual time of the last adaptable 1–2, 2–3 or 3–4 shift. The shift time is based on the gear ratio change after the commanded 1–2, 2–3 or 3–4 shift.

1-2 SOLENOID

2-3 SOLENOID

Range: _____ ON/OFF

Indicates the PCM commanded valve state of the 1–2 and 2–3 solenoids. All the shift solenoids are normally closed. This means that no fluid passes through when the solenoid is commanded OFF. When commanded ON, the solenoid opens and allows fluid to flow.

As shown in Table 18-8, the solenoid ON and OFF states match certain gear positions. Check the factory manual for a chart for the specific transmission being serviced.

Table 18-8 1-2 and 2-3 solenoid parameter readings

1-2 Solenoid	2-3 Solenoid	Gear
ON	ON	1st
OFF	ON	2nd
OFF	OFF	3rd
ON	OFF	4th

1-2 SOL CKT STATUS
2-3 SOL CKT STATUS
3-2 SOL CKT STATUS
TCC DUTY SOL CKT STATUS
TCC ENAB SOL CKT STATUS

Range: _____ **see below**

Indicates the status of the solenoid valve driver feedback voltage signal circuit:

- OPEN/SHORTED displays if the voltage is low when the solenoid is commanded off.
- SHORT TO VOLTS display if the voltage is high when the solenoid is commanded on.
- OK displays if no circuit fault is present.
- INDETERMINATE displays if the control module cannot determine the circuit status or an invalid signal was received.

1ST GEAR

Range: _____ **actual**

Indicates the gear commanded by the module.

2 INDICATOR

Range: _____ **ON/OFF**

Indicates the status of the 2 indicator lamp on the instrument panel. It should only read ON when the 2 position lamp is lighted.

2 POS SWITCH

2ND SELECTED

Range: _____ **ON/OFF**

Indicates whether the contacts to the 2nd gear position switch are closed or open. Reads ON when the switch contacts are closed and the vehicle is in 2nd gear.

2-3T_CCS

Range: _____ **ON/OFF**

Indicates the coast clutch solenoid.

2-4 BRK PRS SW

Range: _____ **ON/OFF**

Indicates the 2–4 brake pressure switch.

2-4 BRK SOL(%)

Range: _____ **0 to 100%**

Indicates the 2–4 brake solenoid.

24B(%)

Range: _____ **0 to 100%**

Indicates the 2–4 brake solenoid.

2ND GEAR

Range: _____ **actual**

Indicates the gear commanded by the module.

2nd PRESSURE SWITCH

2nd PRESSURE SWT

Range: _____ **ON/OFF**

Indicates the status of the 2nd gear pressure switch. Reads ON when the transmission is operating in 2nd gear, it reads OFF at all other times.

3-2 DWNSHIFT SOLRange: _____ **ON/OFF**

Indicates the PCM commanded valve state of the 3–2 downshift solenoid. The solenoid commanded state is based on transmission temperature and will change states during a 3–2 downshift to regulate the appropriate pressure. The commanded state of the solenoid should change with an increase of throttle at approximately 30 MPH (48 MPH).

3-2 TIMERange: _____ **ON/OFF**

Indicates the 3–2 timing solenoid valve.

3-2 TIMING SOLRange: _____ **ON/OFF**

Indicates the 3–2 timing solenoid valve.

3RD GEARRange: _____ **actual**

Indicates the gear commanded by the module.

3rd PRESSURE SWITCH**3rd PRESSURE SWT**Range: _____ **ON/OFF**

Indicates the status of the 3rd gear pressure switch. Reads ON when the transmission is operating in 3rd gear, it reads OFF at all other times.

4-3 DOWNSHIFTRange: _____ **YES/NO**

Indicates whether the ECM has recognized the 4-3 downshift, it reads ON during a recognized a 4-3 downshift, which should unlock the torque converter clutch on some models. When ON, related parameters should be:

- 4-3 DOWNSHIFT reads YES
- TCC COMMAND reads OFF.

4TH GEARRange: _____ **actual**

Indicates the gear commanded by the module.

4th PRESSURE SWITCH**4th PRESSURE SWT**Range: _____ **ON/OFF**

Indicates the status of the 4th gear pressure switch. Reads ON when the transmission is operating in 4th gear, it reads OFF at all other times.

4WDCPWMOURange: _____ **ON/OFF/FAIL/B+**

Indicates the 4WD clutch PWM status.

4WDCPWMSTRange: _____ **variable**

Indicates the 4WD clutch PWM status.

4WDMODE_LRange: _____ **ON/OFF**

Indicates the 4x4 low mode.

5TH GEARRange: _____ **actual**

Indicates the gear commanded by the module.

A/C ENABLEDRange: _____ **ON/OFF**

Indicates the air conditioning switch

A/T 1 SWITCH**A/T 1 SWT**Range: _____ **ON/OFF**

Indicates the status of the A/T 1 position switch. Reads ON only when the shift selector lever is in the 1 position.

A/T 2 SWITCH**A/T 2 SWT**Range: _____ **ON/OFF**

Indicates the status of the A/T 2 position switch. Reads ON only when the shift selector lever is in the 2 position.

A/T 2-1 SWITCH**A/T 2-1 SWT**Range: _____ **ON/OFF**

Indicates the status of the A/T 2–1 position switch. Reads ON when the shift selector lever is in either the 1 or 2 position.

A/T C.P.C. SOL VLV A ACTUAL**A/T C.P.C. SOL VLV B ACTUAL****A/T C.P.C. SOL VLV C ACTUAL****SOL A ACT****SOL B ACT****SOL C ACT**Range: _____ **not available**

Indicates the actual current being applied to clutch pressure control solenoid valves A, B, and C in amperes.

A/T C.P.C. SOL VLV A COMMAND**A/T C.P.C. SOL VLV B COMMAND****A/T C.P.C. SOL VLV C COMMAND****SOL A CMD****SOL B CMD****SOL C CMD**Range: _____ **not available**

Indicates the TCM commanded current being applied to the clutch pressure control solenoid valve A in amperes.

A/T D SWITCH**A/T D SWT**Range: _____ **ON/OFF**

Indicates the status of the A/T D position switch. Reads ON only when the shift selector lever is in the D position.

A/T D3 SWITCH**A/T D3 SWT**Range: _____ **ON/OFF**

Indicates the status of the A/T D3 position switch. Reads ON only when the shift selector lever is in the D3 position.

A/T D4 SWITCH**A/T D4 SWT**Range: _____ **ON/OFF**

Indicates the status of the A/T D4 position switch. Reads ON only when the shift selector lever is in the D4 position.

A/T D5 SWITCH**A/T D5 SWT**Range: _____ **ON/OFF**

Indicates the status of the A/T D5 position switch. Reads ON only when the shift selector lever is in the D5 position.

A/T N SWITCH**A/T N SWT**Range: _____ **ON/OFF**

Indicates the status of the A/T N position switch. Reads ON only when the shift selector lever is in the N position.

A/T NP SWITCHRange: _____ **ON/OFF**

Indicates the status of the A/T NP position switch. Reads ON when the shift selector lever is in either the N or P position.

A/T P SWITCH**A/T P SWT**Range: _____ **ON/OFF**

Indicates the status of the A/T P position switch. Reads ON only when the shift selector lever is in the P position.

A/T R SWITCH**A/T R SWT**Range: _____ **ON/OFF**

Indicates the status of the A/T R position switch. Reads ON only when the shift selector lever is in the R position.

A/T SHIFT SOL VLV A**A/T SHIFT SOL VLV B****A/T SHIFT SOL VLV C****A/T SHIFT SOL VLV D****A/T SHIFT SOL VLV E****SHIFT SOL A****SHIFT SOL B****SHIFT SOL C****SHIFT SOL D****SHIFT SOL E**Range: _____ **ON/OFF**

Indicates the status of the automatic transmission shift solenoid valves A, B, C, D, and E. Reads ON when the indicated solenoid valve is energized to charge the fluid line.

**A/T T.C.C. SOL VLV
A/T T.C.C. SOL VLV A**Range: _____ **ON/OFF**

Indicates the status of the torque converter clutch solenoid valve. Reads ON when the TCC solenoid valve is energized. When the solenoid valve is energized, modulator pressure and lockup are controlled electronically.

ABS_ACTIVRange: _____ **ON/OFF**

No additional information is available for this parameter.

ACCEL SWITCHRange: _____ **ON/OFF**

Indicates the position of the accelerator pedal. The transmission control module (TCM) uses this parameter to determine gear engagement when the vehicle is stopped. It reads:

- ON with the vehicle stopped and the pedal completely released, causing the TCM to engage 2nd gear ("creep" mode).
- OFF when the vehicle is stopped and the pedal is depressed, causing the TCM to engage 1st gear

ACCS=A/CRange: _____ **ON/OFF**

Indicates the air conditioning status.

ACT VLV TMNG(°)Range: _____ **variable**

Indicates the actual valve timing.

AFSA**AFSB**Range: _____ **LOW/HIGH**

Indicates an ECM request to the PGM-FI ECM to retard the ignition timing in order to reduce shift shock during gear changes. Normal reading is LOW. A HIGH reading indicates that an ignition timing retard request signal has been sent, simultaneously the FAS parameter should read LOW.

AP SENSOR (V)**AP SENSOR (A)****AP SENSOR (B)****AP SENSOR1 V****AP SENSOR2 V****AP SENSOR A VOLT****AP SENSOR B VOLT**Range: _____ **0.0 to 5.0 V**

Indicates the accelerator pedal position (APP) as voltage, it should read:

- About 0.35–0.95 V at idle
- Above 4.0 V at wide open throttle

The displayed value should increase smoothly as the accelerator moves from closed to WOT. Some models use multiple APP sensors, the ECM only requires information from one sensor, the others serve as a fail safe.

AP SENSOR DEG (°)Range: _____ **0 to 180°**

Indicates the accelerator pedal position (APP) as a percentage, it normally reads:

- 0° at idle
- 180° at wide open throttle (WOT)

The displayed value should increase smoothly as the accelerator moves from closed to WOT. Some models use multiple APP sensors, the ECM only requires information from one sensor, the others serve as a fail safe.

ASCD CRUISE

Range: _____ ON/OFF

Indicates whether the automatic speed control (cruise) has been activated, it reads ON when cruise control is on.

AT OD CANCEL

Range: _____ ON/OFF

Indicates the status of the overdrive switch, reads ON when the cancel switch is on. With a manual transmission, this parameter always reads OFF.

ATF INDICATOR**ATF SENSOR****ATF TEMP SENSOR (°)****FLUID TEMP (°)****TRANS FLUID (°)****TRANS TEMP (°)****TFT (°)**

Range: _____ -58 to 340°F or -50 to 170°C

Indicates the temperature of the automatic transmission fluid (ATF), which is calculated by the TCM based on the signal voltage of a thermistor-type temperature sensor.

ATF TEMP SENSOR (V)**FLUID TEMP (V)**

Range: _____ 0.0 to 5.0 V

Indicates the signal voltage of the automatic transmission fluid (ATF) temperature sensor.

ATF TEMP INDICATOR

Range: _____ ON/OFF

Indicates the status of the automatic transmission fluid (ATF) overheat indicator lamp. Normal reading is OFF. It reads ON, and the lamp is lit, only when the ATF exceeds the maximum recommended temperature.

BARO**BARO(V)**

Range: _____ 2.6 to 4.6 V

Indicates barometric pressure as voltage and should read as follows:

- 4.6 V at sea level
- 2.6 V at an elevation of 10,000 feet

BATT(V)

Range: _____ 0 to 16 V

Indicates the battery voltage.

BLOWR FAN SW

Range: _____ ON/OFF

Indicates the blower motor.

BOO		
BrakeOnOff		
Range:	_____	ON/OFF
Indicates the brake on and off.		
BRAKE SW		
Range:	_____	ON/OFF
Indicates the brake switch input status.		
CALC TPS(%)		
Range:	_____	0 to 100%
Indicates a calculated value determined by the accelerator pedal position and the actual throttle position. The parameter represents the driver's intended request for torque or acceleration and is used to optimize transmission controls.		
<ul style="list-style-type: none"> • 0% represents an idle or coast request. • 100% represents a request for wide open throttle (WOT) 		
CASeGND(V)		
Range:	_____	-16.0 V to 16.0 V
Indicates the case ground.		
CCS_FAULT		
CCSFault		
Range:	_____	YES/NO
Indicates the coast clutch solenoid status.		
CLCH_SOL(%)		
Range:	_____	0 to 100%
Indicates the (PWM) output control command #1.		
CoastClSol(mA)		
Range:	_____	not available
Indicates the coast clutch solenoid in milli-amps.		
CoastClutchSol		
Range:	_____	ON/OFF
Indicates the coast clutch solenoid.		
COUNTERSHAFT SPEED (km.h)(MPH)		
Range:	_____	0 to vehicle max.
Indicates the vehicle speed based on the countershaft speed, which is determined by the signal of the counterspeed sensor.		
COUNTERSHAFT SPEED (RPM)		
Range:	_____	0 to vehicle max.
Indicates the rotational speed of the countershaft, which is based on the signal form the counterspeed sensor.		
CPP_SW		
Range:	_____	DEPRESSED/RELEASED
Indicates the clutch pedal position switch.		

CURRENT GEAR

Range: _____ 1ST, 2ND, 3RD, 4TH, or CREEP

GEAR

Range: _____ 1, 2 3, or 4

Indicates the gear the transmission is currently operating in.

On some models, a "1" value can be either reverse, drive, or first gear. If the transmission is between gears "CREEP" or "???" may display, "???" can also indicate an invalid signal is being received.

D INDICATOR

Range: _____ ON/OFF

Indicates the status of the D indicator lamp on the instrument panel. It should only read ON when the D position lamp is lighted.

D POS SWITCH

Range: _____ ON/OFF

Indicates the status of the drive position switch. It reads ON when the switch contacts are closed and the vehicle is in drive.

D SWITCH

Range: _____ actual

Indicates the transmission D range switch.

D3 INDICATOR

Range: _____ ON/OFF

Indicates the status of the D3 indicator lamp on the instrument panel. It should only read ON when the D3 position lamp is lighted.

D3 SWITCH

Range: _____ ON/OFF

Indicates the status of the D3 switch. It reads ON only when the shift selector lever is in the D3 position.

D4 INDICATOR**D4/D5/D INDICATOR****D5 INDICATOR**

Range: _____ ON/OFF

Indicates the status of the highest drive position lamp (D, D4, or D5) on the instrument panel. It should only read ON when the lamp is lighted.

When the shift lever is shifted to the highest D position, the D4/D5/D indicator reads ON.

D5 SWITCH

Range: _____ ON/OFF

Indicates the status of the D5 switch. It reads ON only when the shift selector lever is in the D5 position.

DCCSV DC (%)

Range: _____ 0 to 100.0%

DCCSV SLIP (RPM)

Range: _____ 0 to 510 rpm

Indicates the TCM calculated damper clutch control solenoid valve (DCCSV) slip rate. An RPM value is the speed difference between the input and output vanes of the torque converter. A percentage is the duty cycle of the pulse-width-modulated (PWM) signal being applied to the solenoid. This solenoid applies hydraulic pressure to the torque converter.

DFT ERROR CODE (\$XX)

Range: _____ see below

Indicates the cause of a direct function test (DFT) error as a hex value:

- \$00: Not under testing (NOT TST)
- \$01: Oil temperature too low (EOT LO)
- \$02: Oil temperature too high (EOT HI)
- \$03: Engine speed too low (RPM LO)
- \$04: Engine speed too high (RPM HI)
- \$05: Wrong throttle condition (TPS)
- \$06: Throttle position too low (TPS LO)
- \$07: Throttle position too hi (TPS HI)
- \$08: Wrong vehicle speed condition (VSS)
- \$09: Vehicle speed too low (VSS LO)
- \$0A: Vehicle speed to high.
- \$0B Brake switch off (BOO OFF)
- \$0C Brake switch on. (BOO ON)
- \$0D: Wrong shift lever position (MLP POS)
- \$20: Any failure is detected "Failure"
- \$21 No main shaft speed signal (M-Shaft)
- \$22: 2nd gear oil pressure malfunction 2nd GR.
- \$23: 3rd gear oil pressure malfunction 3rd GR.
- \$24: 4th gear oil pressure malfunction 4th GR.
- \$FF: Unknown error (ERROR)

DFT MONITOR (\$XX)

Range: _____ see below

Indicates the direct function test (DFT) monitor as a hex value:

- \$00: Normal (NORMAL)
- \$01: Under test operation (TESTING)
- \$04: Complete (COMPLETE)
- \$0E: Test aborted (TESTER command) (ABORTED)
- \$0F: Test aborted (Wrong condition) (ABORTED)

DFT RESULT (\$XX)

Range: _____ see below

Indicates the direct function test (DFT) results as a hex value:

- \$00: Normal (NORMAL)
- \$02: Solenoid malfunction (SOLENOID)
- \$20: 3rd gear oil pressure switch malfunction (3rd GEAR)
- \$30: 4th gear oil pressure switch malfunction condition (4th GEAR)

DOWNSHIFT REQ 1**DOWNSHIFT REQ 2****DOWNSHIFT REQUEST 1****DOWNSHIFT REQUEST 2**

Range: _____ **ON/OFF**

Indicates whether a downshift has been requested in order to maintain vehicle speed while cruise control is on. Reads ON when the TCM requests a downshift.

DOWNSHIFT SWITCH**DOWNSHIFT SWT****DWN_SW**

Range: _____ **ON/OFF**

Indicates the status of the downshift switch, which is determined by the shift selector lever position, it reads ON if the selector is moved to a lower range.

DRIVE Count**DRIVECNT****DTC****DTC_CNT**

Range: _____ **0 to 255**

Indicates the valid drive counter.

DRIVE POSITION

Range: _____ **ON/OFF**

Indicates the status of the drive position switch. It reads ON only when the shift selector lever is in any forward position, reads OFF in P, R, or N.

DRV_SW

Range: _____ **ON/OFF**

Indicates the drive switch.

DWN_SW

Range: _____ **ON/OFF**

Indicates the downshift switch.

ECL (%)

Range: _____ **95 to 105%**

Indicates the status of the clutch slip ratio as a percentage. Check after warm up in D4 range at a steady cruise speed.

ECT(V)

Range: _____ **0.0 to 5.0 V**

Indicates the engine coolant temperature voltage.

ECT_TCM

Range: _____ **0.0 to 5.0 V**

Indicates the (ECT) transmission control module.

ElecPrsCtrl**EPC**

Range: _____ **0 to 100%**

Indicates the electronic pressure control.

EPC(V)

Range: _____ 0.0 to 5.0 V

Indicates the electronic pressure control voltage.

ENGINE SPEED (RPM)

Range: _____ 0 to engine max.

Indicates engine speed as converted from the crankshaft position (CKP) sensor. The value of each 50 RPM is displayed.

ENGINE SPEED2 (RPM)

Range: _____ 0 to engine max.

Indicates engine speed as converted from the crankshaft position (CKP) sensor. The value of each RPM is displayed.

ESTIMAT SPD RAT

Range: _____ variable

Indicates the estimated turbine speed divided by the transmission output speed (gear ratio). Estimated turbine speed is calculated from engine speed and engine torque.

ETR (%)

Range: _____ 0 to 100%

Indicates the electric control lock-up clutch slip ratio. A 100% reading indicates the lock-up clutch is fully engaged.

FAS

Range: _____ LOW/HIGH

Indicates an ECM request to the PGM-FI ECM to retard the ignition timing in order to reduce shift shock during gear changes. Normally reads HIGH. A LOW reading means an ignition timing retard request signal has been sent, the AFSA or AFSB parameter should also read LOW.

FAT TERMINAL

Range: _____ ON/OFF

Indicates the (DLC) fat terminal.

FLG_OTLK

Range: _____ YES/NO

Indicates the transmission over-temperature lock-up mode.

FLUID_TEMP**FLUID TEMP(V)**

Range: _____ 0.0 to 5.0 V

Indicates the transmission fluid temperature.

FORWARD SWITCH

Range: _____ ON/OFF

Indicates the status of the forward position switch. It reads ON only when the shift selector lever is in any forward position, it reads OFF in P, R, or N.

GEAR

Range: _____ actual

Indicates the gear commanded by the module.

GEAR_MAX

Range: _____ variable

Indicates the highest gear allowed.

GEAR_RA
GEAR RAT
 Range: _____ **0 to 100%**

Indicates the transmission gear ratio.

GEAR RATIO
GR_RATIO
 Range: _____ **0.000 to 8.00:1**

Indicates the TCM calculated actual gear ratio of the current commanded gear. The value is the input shaft speed divided by the output speed in R, D4, D3, D2, and D1 range. The value is the turbine speed divided by the output speed in D5 range with the TCC locked.

GEN LIGHT
 Range: _____ **ON/OFF**

Indicates the generator warning light.

GEN OUT(V)
 Range: _____ **0 to 18 V**

Indicates the generator output voltage.

GEN(%)
 Range: _____ **0 to 100%**

Indicates the generator field current control duty signal.

HC PRES SW
 Range: _____ **ON/OFF**

Indicates the high clutch pressure switch.

HC(%)
HC_SOL(%)
 Range: _____ **0 to 100%**

Indicates the high clutch solenoid.

HEADLIGHT SW
 Range: _____ **ON/OFF**

Indicates the headlight switch.

HI CLUTCH(%)
 Range: _____ **0 to 100%**

Indicates the high clutch solenoid.

HI PS PRESSURE
 Range: _____ **ON/OFF**

Indicates the power steering pressure switch.

HIGH GEAR
 Range: _____ **YES/NO**

Indicates whether the high gear contacts in the transmission are open or closed, it reads YES when the contacts are closed.

HOLD LIGHT
 Range: _____ **ON/OFF**

Indicates the transmission control indicator/hold light.

HOLD SWITCHRange: _____ **ON/OFF**

Indicates the overdrive cancel switch/hold switch.

HOT MODERange: _____ **ON/OFF****NOTE:**

The temperature values stated are approximate and vary by transmission application and calibration.

Indicates hot mode status. Reads ON when the transmission is operating in hot mode. The transmission enters hot mode operation if the transmission fluid temperature exceed 266°F (130°C) and has not cooled to 248°F (120°C) for more than 5 seconds. During hot mode, the TCC engages in 4th gear until the temperature drops below 266°F (130°C), the brakes are applied, or the TP sensor signal is low. On some transmissions, if the temperature reaches 302 to 307°F (150 to 153°C) for 15 minutes, a DTC sets, or if the fluid temperature exceeds 309°F (154°C) for 1 second. Hot mode continues until the next ignition cycle.

HTM_CNTRange: _____ **0 to 255**

High Temperature Mode count.

HTM_DISRange: _____ **actual**

Indicates the distance traveled since high temperature.

IAC=IDLE AIR(%)Range: _____ **0 to 100%**

Indicates the idle air control.

IAT=ACTRange: _____ **-40 to 399°F or -40 to 199°C**

Indicates the intake air temperature.

IAT=ACT(V)Range: _____ **0.0 to 5.0 V**

Indicates the intake air temperature voltage.

IGN ADVANCE(°)Range: _____ **-90° to +90°**

Indicates the spark advance.

IGN_VRange: _____ **0.0 to 16.0 V**

Indicates the ignition voltage.

ILM CONTROLRange: _____ **ON/OFF**

Indicates the Illumination control system operating status. When the ECU is in fail-safe mode, the indicator lamp blinks as a warning lamp according to the illumination dimming cancel signal. Therefore the dimming cancel signal is sent to the dimming circuit to ensure the amount of light even when the parking lamps or headlights are lit. Normally, when the voltage is low, dimming is enabled. In fail-safe or service check mode, the voltage is high, and dimming is disabled.

INDICATORSRange: _____ **ON/OFF**

Indicates whether a DTC exists for any of the range indicator lamps on the instrument panel. The reading alternates between ON and OFF if there is a DTC present, the appropriate indicator light blinks as well.

INGEARRange: _____ **YES/NO**

Indicates the in gear status.

INJ(mS)Range: _____ **0.0 to 99.9 mS**

Indicates the fuel pulse width.

INPUT RPMRange: _____ **actual**

Indicates the turbine shaft speed.

K/D SERVO SWRange: _____ **ON/OFF**

Indicates the status of the kickdown servo, which activates the piston that controls the kickdown band. It reads OFF when the kickdown band is applied; it reads ON when the kickdown band is not applied.

K/D SW**KICKDOWN SW**Range: _____ **ON/OFF**

Indicates the ECM command for a downshift during acceleration, it reads ON if the ECM has commanded a downshift.

KICK-DOWN SWITCHRange: _____ **ON/OFF**

Indicates the status of an accelerator pedal switch. It reads ON when the pedal is fully depressed to initiate a transmission downshift.

L SWITCHRange: _____ **ON/OFF**

Indicates the transmission L range switch.

LAST SHFT (SEC)Range: _____ **0 to 6.38 seconds**

Indicates the actual shift time of the last upshift.

LEDARange: _____ **ON/OFF**

Indicates the status of the shift indicator light control. It reads ON when the gear selector lever is in 4th or 5th position in the sequential mode.

LEDBRange: _____ **ON/OFF**

Indicates the status of the shift indicator light control. It reads ON when the gear selector lever is in 2nd or 3rd position in the sequential mode.

LEDCRange: _____ **ON/OFF**

Indicates the status of the shift indicator light control. It reads ON when the gear selector lever is in 1st, 3rd, or 5th position in the sequential mode.

LEVER POSRange: _____ **P/N, REV, DRIVE, 2ND, 1ST**

Indicates the position of the shift selector lever.

LINE PRES (%)**LPS (%)**Range: _____ **0 to 100%**

Indicates the duty cycle of the ECM command to the line pressure solenoid. The ECM relies on the TP sensor to raise or lower line pressure. When the system functions properly, the larger the throttle opening, the higher the percentage (solenoid on-time), and the greater the line pressure.

LINEDES (%)Range: _____ **0 to 100%**

Indicates the desired line pressure the ECM is attempting to maintain as a percentage of base line pressure. The value indicates target modifier pressure and target pressure of the control solenoid valve.

LOAD PCT(%)Range: _____ **0 to 100%**

Indicates the engine load.

LOAD(%)Range: _____ **0 to 100%**

Indicates the engine load.

LOCKUP B DUTY (%)Range: _____ **0 to 100%**

Indicates the duty cycle of the signal being applied to lockup solenoid B. When the solenoid valve is energized, the fluid line is changed.

LOW HOLD INDICATORRange: _____ **ON/OFF**

Indicates the status of the low/hold indicator lamp on the instrument panel. Reads ON when the panel lamp is on.

LOW HOLD SWITCH**LOW HOLD SWT**Range: _____ **ON/OFF**

Indicates the status of the low/hold switch on. Reads ON when the switch is on.

LPS(%)**LPSB(%)**Range: _____ **0 to 100%**

Indicates the line pressure solenoid percentage, or the line pressure solenoid B percentage.

LPS(A)Range: _____ **0.0 to 5.0 A**

Indicates the line pressure solenoid.

LRB(%)
 Range: _____ 0 to 100%

There is no additional information available for this parameter.

MAF(V)
MAF=MASS AIR(V)
 Range: _____ 0.0 to 5.0 V

Indicates mass air flow.

MAINSHAFT SPEED (KPH)(MPH)
 Range: _____ 0 to vehicle max.

Indicates the vehicle speed based on the mainshaft speed, which is determined by the signal of the counterspeed sensor.

MANUAL MODE INDICATOR
 Range: _____ ON/OFF

Indicates whether the shift selector lever is operating in the manual mode position, it reads ON when in manual mode.

MEAS_SSC(A)
 Range: _____ 0.0 to 5.0 A

Indicates the measured current shift solenoid C.

MEAS_SSD(A)
 Range: _____ 0.0 to 5.0 A

Indicates the measured current shift solenoid D.

MEAS_SSE(A)
 Range: _____ 0.0 to 5.0 A

Indicates the measured current shift solenoid E.

MEAS_SSF(A)
 Range: _____ 0.0 to 5.0 A

Indicates the measured current shift solenoid F.

MIL
 Range: _____ ON/OFF

Indicates the malfunction indicator lamp.

MLN_SW
 Range: _____ ON/OFF

Indicates whether the throttle plate is open.

MNL_SW
 Range: _____ ON/OFF

Indicates the manual range switch.

MTSW
 Range: _____ AT/MT

Indicates manual trans/auto trans discrimination signal.

N INDICATOR
 Range: _____ ON/OFF

Indicates the status of the N indicator lamp on the instrument panel. It should only read ON when the N position lamp is lighted.

N SWITCH	Range: _____	ON/OFF
Indicates the park/neutral status.		
NC(0) RPM		
NC(2) RPM	Range: _____	0 to vehicle max.
Indicates the direct clutch engagement RPM. These clutches rotate in forward gears, and are held in reverse and overdrive.		
NEUT_SW(MTX)	Range: _____	ON/OFF
Indicates the neutral switch circuit.		
N-SHIFT SOL	Range: _____	ON/OFF
Indicates the N-Shift solenoid.		
O/D OFF INDICATOR	Range: _____	ON/OFF
Indicates the status of the dash-mounted OD lamp, reads ON when the lamp is off.		
O/D OFF_HOLD SW		
OD OFF SW	Range: _____	ON/OFF
Indicates the overdrive cancel switch/hold switch.		
O/D SW		
O/D SWITCH		
OVERDRIVE SW	Range: _____	ON/OFF
OD ENABLED	Range: _____	YES/NO
Indicates the position of the overdrive control switch:		
<ul style="list-style-type: none"> • YES or ON when the switch is on, overdrive allowed. • NO or OFF when the switch is off, overdrive prevented. 		
O/D SOLENOID	Range: _____	ON/OFF
Indicates the status of the overdrive solenoid, reads ON when the solenoid is energized.		
OD CUT #2	Range: _____	ON/OFF
Indicates the status of the dash-mounted overdrive switch, it reads ON when the switch contacts are closed. This prevents the transmission from shifting into overdrive and turns on a panel lamp.		
OD INDICATOR	Range: _____	ON/OFF
Indicates the status of the dash-mounted OD lamp, reads ON when the lamp is on.		
OD OFF LIGHT	Range: _____	ON/OFF
Indicates the transmission control indicator light.		

ODOMETER (km)(miles)

Range: _____ actual distance

Indicates the distance driven since the TCM (PCM) was last reset.

OP_SW

Range: _____ ON/OFF

Indicates the oil pressure switch.

OP_SW_24B

Range: _____ ON/OFF

Indicates the 2–4 brake pressure switch.

OP_SW_LRB

Range: _____ ON/OFF

Indicates the oil pressure switch.

OS_SRC

Range: _____ 0 to vehicle max.

Indicates the output shaft speed.

OSS(RPM)

Range: _____ 0 to vehicle max.

Indicates the output shaft speed.

OSS_FAULT

Range: _____ YES/NO

Indicates the output shaft speed status.

OutShftSp(RPM)

Range: _____ 0 to vehicle max.

Indicates the output shaft speed.

OUTPUT RPM

Range: _____ 0 to vehicle max.

Indicates the speed of the transmission output shaft.

OVERRUN CLUTCH

Range: _____ ON/OFF

Indicates the ECM command status for the overrun clutch solenoid valve. The solenoid valve should be open when the reading is ON.

P INDICATOR

Range: _____ ON/OFF

Indicates the status of the P indicator lamp on the instrument panel. It should only read ON when the P position lamp is lighted.

P/E/HOLD SW

Range: _____ PWR/ECON/HOLD

Indicates the position of the power economy shift pattern switch. The display should change to agree with the current switch position. If the switch is in the economy position, the transmission shift pattern is altered to economize fuel consumption.

P/N POSI SW
PNP SWITCH
PNP_SW
PNP SWT

Range: _____ **ON/OFF**

Indicates the position of the park/neutral position (PNP) switch, it should read on only with the gear selector lever in N or P position.

P/N SWITCH
PNP SW (NSW)

Range: _____ **see below**

Indicates the signal from the park/neutral position (PNP) switch.

What characters display in the range depend on the vehicle. On most, the readings for this parameter are: PARK, REV, NEUT, DRIVE, 2ND, and LOW. Others use either P-N-- for park and neutral or -R-DL for reverse and forward gears.

If the range displays a number, that number corresponds to the presently engaged gear. The display shows question marks (????) between gears or when the signal is invalid.

P/N_POS
ParkNeuPos

Range: _____ **PARK/NEUT**

Indicates the Park/Neutral position.

P/S PRESS SW

Range: _____ **ON/OFF**

Indicates the power steering pressure switch.

PCA

Range: _____ **not available**

Indicates the pressure control solenoid A.

PCA_FAULT

Range: _____ **YES/NO**

Indicates the pressure control solenoid A status.

PCAA(A)

Range: _____ **0.0 to 5.0 A**

Indicates the pressure control solenoid A (AMP).

PCB

Range: _____ **not available**

Indicates the pressure control solenoid B.

PCB_FAULT

Range: _____ **YES/NO**

Indicates the pressure control solenoid B status.

PCBA(A)

Range: _____ **0.0 to 5.0 A**

Indicates the pressure control solenoid B (AMP).

PCF

Range: _____ **not available**

Indicates the line pressure control.

PCF_FAULTRange: _____ **YES/NO**

Indicates the line pressure control status.

PCFA(A)Range: _____ **0.0 to 5.0 A**

Indicates the line pressure control (AMP).

PCGRange: _____ **not available**

Indicates the converter pressure control.

PCG_FAULTRange: _____ **YES/NO**

Indicates the converter pressure control status.

PCSV DC (%)Range: _____ **0 to 100.0%**

Indicates the duty cycle (DC) of the pulse-width-modulated (PWM) signal being applied to the pressure control solenoid valve (PCSV). The PCSV regulates hydraulic pressure to the clutches during shifts.

PCS ACT(AMP)Range: _____ **0 to 1.10 A**

Indicates the actual current of the pressure control A solenoid at the control module.

- High current indicates low line pressure.
- Low current indicates high line pressure.

PCS DES (AMP)Range: _____ **0 to 1.10 A**

Indicates a calculated value determined by the accelerator pedal position and the actual throttle position. The parameter represents the driver's intended request for torque or acceleration and is used to optimize transmission controls.

- 0% represents an idle or coast request.
- 100% represents a request for wide open throttle (WOT).

PCS DUTY(%)**PCS DUTY CYCL(%)**Range: _____ **0 to 100%**

Indicates the duty cycle of the commanded state of the pressure control solenoid (PCS) and reads as follows:

- 0% when the solenoid is not energized.
- About 60% at idle during maximum on-time.

POWERSHIFT SWRange: _____ **ON/OFF**

Indicates whether the vehicle is operating in the power or economy mode. These modes affect when shifts occur, as well as how smoothly the transmission shifts. Reads ON when operating in the power mode.

PNPRange: _____ **ON/OFF**

Indicates the clutch pedal position switch/neutral switch circuit status.

PULSE GEN-A**PULSE GEN-B**

Range: _____ **0 to engine max. rpm**

Indicates input and output shaft speeds calculated by the TCM based on the signals from two pulse-generator sensors installed on transmission:

- PULSE GEN-A represents input shaft speed.
- PULSE GEN-B represents output shaft speed.

The TCM uses these signals to control shift pattern and hydraulic pressure during shifting. Pulse generator A is activated by holes in the kickdown drum. Therefore, generator A does not pulse when the kickdown drum is held (in 2nd gear or 4th gear).

PWR/ECON SW

Range: _____ **PWR/ECON**

Indicates the position of the power economy shift pattern switch. The display should change to agree with the current switch position. If the switch is in the economy position, the transmission shift pattern is altered to economize fuel consumption.

R INDICATOR

Range: _____ **ON/OFF**

Indicates the status of the instrument panel R indicator lamp. Reads ON if the lamp is on.

R SWITCH

Range: _____ **ON/OFF**

Indicates the transmission R range switch.

RED TIMING SOL

Range: _____ **ON/OFF**

Indicates the reduction timing solenoid.

REV POS SWITCH**REV_SW****REVERSE SWITCH**

Range: _____ **ON/OFF**

Indicates the status of the reverse switch. Reads ON when the shift lever is in the R position.

RPM

Range: _____ **not available**

Indicates the engine speed.

S MODE SWITCH

Range: _____ **ON/OFF**

Indicates the status of the mode switch. It reads ON when the switch is on.

S SWITCH

Range: _____ **ON/OFF**

Indicates the transmission S range switch.

SELF DIAG LAMP

Range: _____ **ON/OFF**

Indicates the status of the Powershift or O/D Off lamp on the instrument panel, and the presence of a transmission diagnostic trouble codes on some vehicles. It reads:

- ON if a DTC set, or the lamp is on, or both.
- OFF if no codes set and that the lamp is off.

SFT ERROR CODE (\$XX)

Range: _____ 00 to 30/FF

Indicates the cause of a single function test (DFT) error as a hex value:

- \$00: Not under testing (NOT TEST)
- \$01: Oil temperature too low (EOT LO)
- \$02: Oil temperature too high (EOT HI)
- \$03: Engine speed to low (RPM LO)
- \$04: Engine speed to high (RPM HI)
- \$05: Wrong throttle condition (TPS)
- \$06: Throttle position to low (TPS LO)
- \$07: Throttle position to high (TPS HI)
- \$08: Wrong vehicle speed condition (VSS)
- \$09: Vehicle speed to low (VSS LO)
- \$0A: Vehicle speed to high (VSS HI)
- \$0B: Brake switch OFF (BOO OFF)
- \$0C: Brake switch ON (BOO ON)
- \$0D: Wrong switch lever position (MLP POS)
- \$0E: Engine is running
- \$0F: Operational parameter is out of range
- \$10: Shift request not sequential
- \$11: Shift request too low
- \$12: Shift request too high
- \$13: Water temperature to low
- \$14: Water temperature to high
- \$15: Gear ratio high
- \$16: Gear ratio low
- \$18: Shift selector is not P position
- \$19: Shift selector is not R position
- \$1A: Shift selector is not N position
- \$1B: Shift selector is not D5 position
- \$1C: Shift selector is not D4 position
- \$1D: Shift selector is not D3 position
- \$1E: Shift selector is not 2 position
- \$1F: Shift selector is not 2 position
- \$20: Any failure is detected (FAILURE)
- \$21: No main shaft speed signal (M-SHAFT)
- \$22: 2nd gear oil pressure switch malfunction (2nd GR)
- \$23: 3rd gear oil pressure switch malfunction (3rd GR)
- \$24: 4th gear oil pressure switch malfunction (4th GR)
- \$25: Shift selector is not D position
- \$26: Shift selector is not S position
- \$27: Shift selector is not L position

- \$30: Interrupt request by PGM-FI system
- \$FF: Unknown error (ERROR)

SHIFT A**SHIFT SOL A**Range: _____ **ON/OFF**

Indicates the state of shift solenoid A.

SHIFT B**SHIFT SOL B**Range: _____ **ON/OFF**

Indicates the state of shift solenoid B.

SHIFT SOL CRange: _____ **ON/OFF**

Indicates the state of shift solenoid C.

ShiftSol1**ShiftSol2****ShiftSol3****ShiftSol4**Range: _____ **ON/OFF**

Indicates the PCM commands for the shift solenoids. Reads ON when the PCM has command the solenoid on, reads OFF at all other times.

ShiftSol1Fault**ShiftSol2Fault**Range: _____ **YES/NO**

Indicates the shift solenoid status.

SHIFT CONTROLRange: _____ **variable**

Indicates the shift position that the TCM intends to control the automatic transmission with.

SHIFT LIGHTRange: _____ **ON/OFF**

Indicates an output command from the ECM to the instrument panel lamp on some vehicles with a manual transmission. It reads ON when the panel lamp should be lit.

SHIFT LOCKRange: _____ **LOW/HIGH**

Indicates the status of the shift lock unit, which prevents the shift selector lever from moving out of the "P" position unless the brake pedal is depressed and the throttle pedal is released.

SHIFT LOCK SOLRange: _____ **ON/OFF**

Indicates the status of the shift lock solenoid valve, it reads ON when the solenoid is energized, this releases the shift lock.

SHIFT MAP #**SHIFT MAP NUMBER**Range: _____ **not available**

Indicates changing the speed data number used for internal calculations.

SHIFT SOL A**SHIFT SOL B**

Range: _____ **ON/OFF**

Indicates the ECM command state of the shift solenoid valves (A and B). Reads ON when the solenoid is energized. Compare readings to the table that follows:

Table 18-9 *Shift solenoid relationships*

	1st Gear	2nd Gear	3rd Gear	4th Gear
Shift Solenoid A	ON	OFF	OFF	ON
Shift Solenoid B	ON	ON	OFF	OFF

SCS

Range: _____ **OPEN/SHORT**

Indicates the status of the service check signal. It reads SHORT when the SCS line is grounded. After turning on the ignition switch, the indicator light flashes DTCs.

SLIP_DES

Range: _____ **not available**

Indicates the desired torque converter slip in rpm.

SLN SOLENOID

Range: _____ **ON/OFF**

Indicates the ECM command status for the modulated accumulator back pressure solenoid, which assures smooth shifting. Reads ON when the solenoid is energized.

SLT SOLENOID

Range: _____ **ON/OFF**

Indicates the ECM command status for the SLT solenoid, which modulates main line pressure. Reads ON when the solenoid is energized.

SLU SOLENOID

Range: _____ **ON/OFF**

Indicates the ECM command to the torque converter clutch (TCC). Reads ON or YES when the ECM commands the TCC to engage, and OFF or NO when the TCC is commanded off.

SNOW MODE INDICATOR

Range: _____ **ON/OFF**

Indicates the ECM command status for the Snow Mode indicator lamp on the instrument panel, it should read ON when the lamp is on.

SNOW MODE SWITCH

Range: _____ **ON/OFF**

Indicates the status of the snow mode switch on the instrument panel, it should read ON when the switch is on.

SOL SUPPLY (V)

Range: _____ **variable**

Indicates the status of the supply voltage to the solenoid valves.

SPARK ADV(°)

Range: _____ **actual**

Indicates the spark advance in degrees.

SPEED RATIO

Range: _____ 0.00:1 to 8.00:1

Indicates the ratio of engine speed to transmission speed. This value is used by the TCM to estimate gear ratios.

SS MODE SWITCH**SS MODE SWT**

Range: _____ ON/OFF

Indicates the status of the sequential sportshift mode switch. It reads ON when the shift selector lever is in the sequential sportshift mode position.

SSA_SS1

Range: _____ ON/OFF

Indicates the state of shift solenoid 1.

SSA_SS1(%)

Range: _____ 0 to 100%

Indicates the state of shift solenoid 1 percentage.

SSA_SS1_FAULT

Range: _____ YES/NO

Indicates the state of shift solenoid 1 status.

SSB_SS2

Range: _____ ON/OFF

Indicates the state of shift solenoid 2.

SSB_SS2(%)

Range: _____ 0 to 100%

Indicates the state of shift solenoid 2 percentage.

SSB_SS2_FAULT

Range: _____ YES/NO

Indicates the state of shift solenoid 2 status.

SSC_SS3

Range: _____ ON/OFF

Indicates the state of shift solenoid 3.

SSC_SS3(%)

Range: _____ 0 to 100%

Indicates the state of shift solenoid 3 percentage.

SSD_SS4

Range: _____ ON/OFF

Indicates the state of shift solenoid 4.

SSE_SS5

Range: _____ ON/OFF

Indicates the state of shift solenoid E/5.

SSF_SS6

Range: _____ ON/OFF

Indicates the state of shift solenoid F/6.

SSF(A)
Range: _____ 0 to 5(A)

Indicates the amp draw of shift solenoid F/6.

SSG(A)
Range: _____ 0 to 5(A)

Indicates the amp draw of shift solenoid G.

START SIG
Range: _____ ON/OFF

No additional information is available for this parameter.

T-CASE RATIO
Range: _____ variable

Indicates the ratio of the transfer case, calculated by engine speed, divided by transmission output speed based on transmission commanded gear.

TARG LINE
Range: _____ 60 to 300 psi

Indicates the target modifier pressure/target pressure control solenoid pressure.

TC_SLIP(RPM)
Range: _____ not available

Indicates the torque converter slip actual.

TCC BRAKE SW
Range: _____ OPEN/CLSD

Indicates the status of the torque converter clutch (TCC) brake switch. This is a normally closed, 2 pole switch and may be equipped with a vacuum port. The TCC brake switch supplies ignition voltage to the TCC and a feedback signal to the PCM. When the brake pedal is pressed, the switch opens, ignition voltage is removed from the TCC, and the PCM receives a feedback signal. On models with cruise control, the TCC brake switch is also used to vent the cruise control servo to atmosphere.

Reads OPEN when the brake pedal is applied (switch open) to disengage the torque converter clutch and cruise control, and CLSD when the brake pedal is released (switch closed).

TCC COMMAND

TCCC

TCC PWM ENABLED

TCC SOLENOID

Range: _____ ON/OFF

TCC ENABLED

Range: _____ YES/NO

Indicates the ECM command to the torque converter clutch (TCC). Reads ON or YES when the ECM commands the TCC to engage, and OFF or NO when the TCC is commanded off.

TCC engagement (lockup) depends on gear selection, speed, engine temperature and throttle position. The ECM grounds one side of the circuit that energizes the TCC solenoid. In addition, the circuit must also be completed by various transmission, speed, and brake switches to open the transmission hydraulic line and engage the TCC.

TCC DUTY(%)
Range: _____ 0 to 100%

Indicates the commanded duty cycle of the TCC solenoid and reads as follows:

- 90% = the TCC solenoid is fully energized.
- 0%= the TCC solenoid is off.

TCC EFFICIENCY

Range: _____ **0.0 to 2.0:1**

Indicates a ratio which is calculated by multiplying the speed ratio by a value related to the "K factor" of the torque converter. The "K factor" is the looseness or tightness of the torque converter for a given torque.

The nearer the torque converter is to full coupling (1.0:1), the closer the torque converter efficiency number will be to 1.

TCC ENABLED**TCC ENABLE SOL****TCC SOL**

Range: _____ **YES/NO**

Indicates the PCM commanded state of the torque converter clutch (TCC) solenoid and reads YES when the TCC solenoid is energized.

TCC GROUNDED

Range: _____ **YES/NO**

Indicates the state of TCC solenoid voltage available at pin F of the ALDL connector on some models. This parameter is not part of the serial data list, and does not appear in a data movie. Interpret the voltage at pin F as follows:

- YES means no voltage (circuit closed to ground)
- NO means high voltage (circuit open)
- If pin F is not present or is open, TCC GROUNDED continuously reads YES.

YES indicates that the ECM has grounded its side of the circuit; it does not indicate that the circuit is complete. The circuit is not complete until all other switches in series are closed. This parameter is useful to eliminate the ECM as the cause of a TCC solenoid that does not energize.

TCC RELEASE

Range: _____ **YES/NO**

Indicates the state of the normally-closed TCC release switch. It reads:

- YES if the switch is open, the TCC is released
- NO if the switch is closed, the TCC is applied

TCC SLIP(RPM)

Range: _____ **0 to engine max. or -4080 to +4079 rpm**

Indicates the TCC slip rate on some 4T60E transaxles and 4L60E and 4L80E transmissions.

For a 4T60E transaxle, TCC SLIP(RPM) reads as follows:

- A negative value means engine speed is less than turbine speed (deceleration).
- A positive value means engine speed is greater than turbine speed (acceleration).
- A value of zero means engine speed equals turbine speed (TCC is applied).

For 4L60E and 4L80E transmissions, the speed difference between input and output vanes of the torque converter displays.

TCC SOL (%)

Range: _____ **0 to 100%**

Indicates the duty cycle of the signal the ECM is applying to the torque converter clutch (TCC) solenoid. As the value increases, so does the degree of TCC lockup.

TCC(%)
Range: _____ 0 to 100%

Indicates the pulse-width-modulated (PWM) signal to the torque converter clutch (TCC).

TCC_FAULT
Range: _____ YES/NO

Indicates a torque converter clutch fault.

TCC_MES(A)
Range: _____ 0.0 to 5.0 A

Indicates the measured current for the TCC pressure control.

TCCA(V)
Range: _____ 0.0 to 5.0 V

Indicates the torque converter clutch actual.

TCCC(%)
Range: _____ 0 to 100%

Indicates the torque converter clutch control solenoid.

TCCFault
Range: _____ YES/NO

Indicates the torque converter clutch fault.

TCCMACT(RPM)
Range: _____ actual

Indicates the torque converter slip actual.

TCIL
Range: _____ ON/OFF

Indicates the transmission control indicator light.

TCIL_FAULT
TCILFault
Range: _____ YES/NO

Indicates the transmission control indicator light fault.

TCS
Range: _____ ON/OFF

Indicates the overdrive cancel switch/hold switch status.

TCS ACTIVE
Range: _____ YES/NO or ACTIVE/INACTIVE

Indicates the status of the traction control system (TCS), it reads:

- YES or ACTIVE when the TCS is operating
- NO or INACTIVE at all other times

TFP SW
Range: _____ PARK, REV, NEUT, 4th, 3rd, 2nd, LOW, INV

Indicates the decoded status of the three A/B/C inputs from the transmission fluid pressure (TFP) manual valve position switch.

The TFP RANGE reading should match the current gear: Park (P), Reverse (R), Neutral (N), Drive 4 (4th), Drive 3 (3rd), Drive 2 (2nd), Drive 1 (1st). INV will display when the PCM does not recognize a valid combination of inputs. See Table 18-10 for example.

Table 18-10 Transmission fluid pressure manual valve switch logic chart

Gear Selector Position	TFP SW(A)	TFP SE(B)	TFP SW(C)
Park (P)	HI	LO	HI
Reverse (R)	LO	LO	HI
Neutral (N)	HI	LO	HI
Drive 4 (4TH)	HI	LO	LO
Drive 3 (3RD)	HI	HI	LO
Drive 2 (2ND)	HI	HI	HI
Drive 1 (1ST)	LO	HI	HI
Invalid (INV)	LO	HI	LO
Drive 1 (1ST)	LO	LO	LO

HI = Ignition voltage
LO = 0 volts

TFP SWITCH A**TFP SWITCH B****TFP SWITCH C**

Range: _____ **ON/OFF**

Indicates the status of the PCM switch (A, B, and C) inputs to the transmission fluid pressure (TFP) switch assembly. Readings are:

- ON when the voltage signal is low and the switch is closed
- OFF when the voltage signal is high and the switch is open

The PCM uses the combination of high and low voltage signals from the switches to determine manual valve position. The manual valve regulates line pressure, TCC engagement, and shift solenoid operation.

TFT

Range: _____ **-40 to 399°F or -40 to 199°C**

Indicates the transmission fluid temperature.

TFT(V)**TrnFluidTmp(V)**

Range: _____ **0.0 to 5.0 V**

Indicates the transmission fluid temperature voltage.

TFT_FAULT

Range: _____ **YES/NO**

Indicates a transmission fluid temperature fault.

THROTTLE SW

Range: _____ **ON/OFF**

Indicates the throttle switch.

THOP(%)**THROTTLE(%)**

Range: _____ **0 to 100%**

Indicates the throttle position.

ThrPosMODE

Range: _____ PT/WOT/CT

Indicates the throttle position.

TORQ DELIV(Nm)

Range: _____ 0 to 691

Indicates the estimated amount of torque in Nm that is delivered from the engine. The ECM sends the engine torque information to the transmission control module (TCM) via the high speed GMLAN serial data line.

TORQUE

Range: _____ actual

Indicates the net engine torque.

TP MODE**TP(%)**

Range: _____ 0 to 100%

Indicates the throttle position percentage.

TP(V)

Range: _____ 0.0 to 5.0 V

Indicates the throttle position voltage.

TP_FAULT

Range: _____ YES/NO

Indicates a throttle position sensor fault.

TP_PER(%)

Range: _____ 0 to 100%

No additional information is available for this parameter.

TP=TPS(V)

Range: _____ 0.0 to 5.0 V

Indicates the throttle position voltage.

TPCT(V)

Range: _____ 0.0 to 5.0 V

Indicates the lowest closed throttle voltage.

TPS(%)

Range: _____ 0 to 100%

Indicates the throttle position percentage.

TPS(V)

Range: _____ 0.0 to 5.0 V

Indicates the throttle position voltage.

TPS/8

Range: _____ 0 to 8

Indicates throttle position angle in 8 increments, read as follows:

- 0 indicates a closed throttle
- 4 indicates half-open throttle
- 8 indicates a wide-open throttle

TR
Range: _____ **actual**

Indicates the transmission range.

TR SW(A)

TR SW(B)

TR SW(C)

TR SW(P)

Range: _____ **HI/LO**

TR SW A/B/C/P

Range: _____ **HI/LO/INV**

Indicates the HI (high) or LO (low) status of the four inputs (A/B/C/P) from the transmission range switch to the PCM.

- HI indicates ignition voltage.
- LO indicates no voltage.
- INV indicates an invalid signal.

The PCM detects the selected gear range by deciphering the combination of the voltage signals. The PCM compares the actual voltage combination of the switch signals to a TR switch combination table stored in memory.

See Table 18-11 for an example.

Table 18-11 *Transmission range switch logic chart*

Gear Selector Position	TFP SW(A)	TFP SE(B)	TFP SW(C)	TFP SW(P)
Park (P)	LO	HI	HI	LO
Reverse (R)	LO	LO	HI	HI
Neutral (N)	HI	LO	HI	LO
Drive 4 (4TH)	HI	LO	LO	HI
Drive 3 (3RD)	LO	LO	LO	LO
Drive 2 (2ND)	LO	HI	LO	HI
Drive 1 (1ST)	HI	HI	LO	LO
HI = Ignition voltage LO = 0 volts INV = Invalid will display if any other combination is received.				

TR SWITCH

Range: _____ **see below**

Indicates the decoded status of the four transmission range (TR) switch signals. The switch (A, B, C, and P) status determines what gear the transmission is operating in, and the current gear (PARK, NEUT, REV, 4TH, 3RD, 2ND, 1ST, or INV). An INV (invalid) reading means the PCM does not recognize a valid combination of inputs.

Switch logic is shown in Table 18-12.

Table 18-12 Transmission range switch logic

Gear Selector Position	TR SW A	TR SW B	TR SW C	TR SW P
Park	LOW	HI	HI	LOW
Reverse	LOW	LOW	HI	HI
Neutral	HI	LOW	HI	LOW
Drive 4	HI	LOW	LOW	HI
Drive 3	LOW	LOW	LOW	LOW
Drive 2	LOW	HI	LOW	HI
Drive 1	HI	HI	LOW	LOW
Invalid	All other combinations.			
HI = Ignition voltage LOW = 0 voltage				

TR_FAULT

Range: _____ YES/NO

Indicates a transmission range fault.

TR_POS

Range: _____ actual

Indicates the transmission range.

TRANS CTRL LAMP

Range: _____ ON/OFF

Indicates the transmission control indicator light.

TRANS SLIP CNT

Range: _____ 0, 1, 2

Indicates the number of times the P0894 diagnostic test has identified a slipping condition. In order to set DTC P0894 (Transmission Component Slipping), the diagnostic test must identify a slipping condition three times in a row.

TR_SNSOR(V)

TransRange_ACTUAL GEAR

TransRange(V)

Range: _____ 0.0 to 5.0 V

Indicates the transmission range.

TransRange_D

TRD

Range: _____ ON/OFF

Indicates the transmission range switch.

TRIP

Range: _____ YES/NO

Indicates the on-board diagnostic trip has completed.

TRIP CouNT

TRIP_CNT

Range: _____ 0 to 255

Indicates the number of on-board diagnostic trips completed.

TRL
Range: _____ ON/OFF

Indicates the transmission L range switch.

TrnAxleRLRN
Range: _____ not available

Transmission Axle Relearn.

TrnCtrlIndLamp
Range: _____ ON/OFF

Indicates the transmission control warning indicator.

TrnCtrlSw
Range: _____ ON/OFF

Indicates the transmission control switch range.

TrnFluidTmp(V)
Range: _____ 0.0 to 5.0 V

Indicates the transmission fluid temperature.

TRR
Range: _____ ON/OFF

Indicates the transmission R range switch.

TRS
Range: _____ ON/OFF

Indicates the transmission S range switch.

TS_SRC
TSS(RPM)
TurbSpdS(RPM)
Range: _____ 0 to vehicle max.

Indicates the turbine shaft speed.

TSLIPRAT(1000:1)
Range: _____ actual

Indicates the transmission slip ratio.

TSS_FAULT
Range: _____ YES/NO

Indicates a turbine shaft speed fault.

UP SHIFT SWITCH
UP SHIFT SWT
Range: _____ ON/OFF

Indicates whether the shift selector lever has been moved to initiate an upshift, reads ON if an upshift has been requested.

UP_SW
Range: _____ ON/OFF

Indicates whether the ECM is allowing an upshift, reads ON when an upshift is allowed.

VBATT(V)
Range: _____ 0.0 to 16.0 V

Indicates the battery position voltage.

VEH SPEED

Range: _____ 0 to vehicle max.

Indicates the vehicle speed.

VPoWeR(V)**VPWR(V)**

Range: _____ 0.0 to 16.0 V

Indicates the battery positive voltage.

VPWR=BATT(V)

Range: _____ 0.0 to 16.0 V

Indicates the module supply voltage.

VSS

Range: _____ 0 to vehicle max.

Indicates the vehicle speed.

VSS (METER)

Range: _____ 0 to vehicle max.

Indicates the digital input from the VSS analog-to-digital converter in the instrument meter.

WAC=WOT A/C

Range: _____ ON/OFF

Indicates the wide open throttle air conditioning cut out.

The vehicles listed in the following sections are specific Asian Import models that may have problems communicating with the scan tool.

A.1 Slow Codes for Many 1988 and Later Mitsubishi, Chrysler Imports, and Hyundai Sonata

Models with the 2.4L 4-cylinder or the 3.0L V6 SOHC engine transmit data at 63 baud rate. It may appear that there is a communication problem when actually, data is transmitting at a very slow speed. The Main Menu for these vehicles displays Codes and Data (Slow).

Readings from these vehicles take up to seven seconds to change. The baud rate, or “data update rate” depends on the ECM; it is not controlled by the scan tool.

A.2 Codes and Data for 1989 and Later Toyota Cressida and Lexus LS400

These vehicles transmit ECM operating data to the scan tool. This test mode appears on the Main Menu as the selection Data (No Codes). These Toyota systems do not transmit trouble codes in this mode. Codes must be read separately by using the Code Functions selection from the Main Menu.

To place the Cressida and Lexus LS400 in a test mode where the ECM is more sensitive to trouble codes, see “Code Sensitivity—OBD-II and some Pre-OBD-II” on page 199.

For a detailed explanation, refer to Troubleshooter References TA043 and TA044.

A.3 1996-2006 Mazda 16 Pin DLC Voltage Chart



To test the terminal voltages:

- Test the terminal voltages using a voltmeter. Figure A-1 maps the data link connector. Refer to Table A-1 for corresponding voltages.

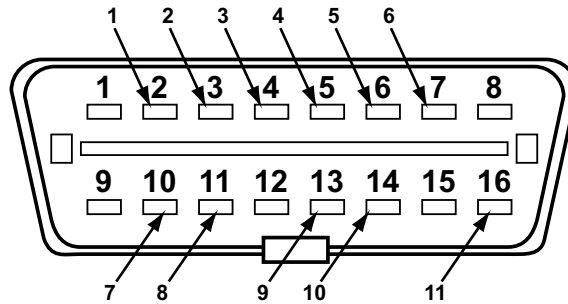

- 1— J1850 BUS +
- 2— CAN medium speed +
- 3— Case ground
- 4— Power ground
- 5— CAN high speed +
- 6— ISO K-line/KW2000
- 7— J1850 BUS –
- 8— CAN medium speed –
- 9— Module programming signal
- 10—CAN high speed –
- 11—Battery B +

Table A-1 Test 16-pin DLC Terminal Voltages

Pin	Protocol	Voltage
2	J1850 +	0.0 V
3	Can Medium Speed +	3.0 V
6	CAN High speed +	2.5 V
7	ISO	7.0 V or greater
	KW2000	12.0 V
10	J1850 -	5.0 V
11	Can Medium Speed -	2.0 V
14	Can High Speed -	2.5 V
NOTE: Voltages may vary with BUS terminal activity		

Figure A-1 Data link connector

A.4 No Communication for 1987–90 Nissan

For a communication problem with all 1987–90 Nissan models except the 1987 Sentra and 1990 300ZX, gather codes manually by placing the ECM in the diagnostic mode and observing two flashing LEDs. This also applies to 1991 Maxima, Axxess, Van, and Pickup models.

See “Code Types 07” on page 125 for detailed instructions.

A.5 GM Control Systems on Isuzu and Isuzu-built Geo

Some Isuzu and Isuzu-built Geo models have General Motors control systems. These vehicles may display a No Communication message when the scan tool and the control module cannot communicate with each other for some reason. Common problems that prevent a vehicle from performing a test or communicating with the scan tool are listed below.

If the Check Engine lamp passes the bulb check, put the ECM into the “field service” mode by turning the ignition on and jumpering pin B to pin A in the 12-pin ALDL connector, or pin A to pin C on the 3-pin ALDL connector (Figure A-2).

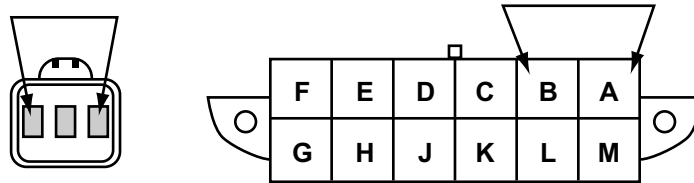

Figure A-2 Jump these pins to flash codes on the Check Engine lamp

The Check Engine lamp should flash code 12 three times. It then flashes any other codes present in ECM memory, or it flashes code 12 again. Code 12 appears on the Check Engine lamp as in Figure A-3.

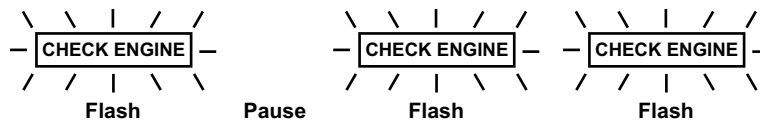

Figure A-3 Code 12 on Check Engine lamp

Several different symptoms and problems may occur at this point:

- If the Check Engine lamp lights for a bulb check but stays off and does not flash any codes, check the continuity between pins A and B in the ALDL connector (A and C on the 3-pin connector).
- If the Check Engine lamp flashes rapidly with no code pattern, check the ECM. Verify that a PROM is installed. Refer to the troubleshooting procedure for the test vehicle.
- If the Check Engine lamp lights steadily and does not flash with ALDL pins A and B jumpered, refer to the factory troubleshooting chart for the specific vehicle.
- Watch for code 51 or other 50-series codes that indicate a PROM or ECM problem. Code 51 means there is either a PROM failure or a missing PROM. Many carbureted engines do not transmit a code 51 on the data stream; and if the PROM is missing, the ECM for these systems does not communicate with the scan tool. However, some ECMs do flash code 51 on the Check Engine lamp.

Most communication problems can be found and corrected by checking the points listed in this section. In a few cases, communication failure may be due to ECM failure. In all cases, check and verify all circuits and parts involved in data communication before condemning the ECM.



NOTE:

You may need a wiring diagram for the specific test vehicle along with troubleshooting procedures from the manufacturer for some of the following checks.

Check the ALDL connector with a digital voltmeter (Figure A-4) if the Check Engine lamp does not flash code 12, or if it does but the scan tool does not receive data.

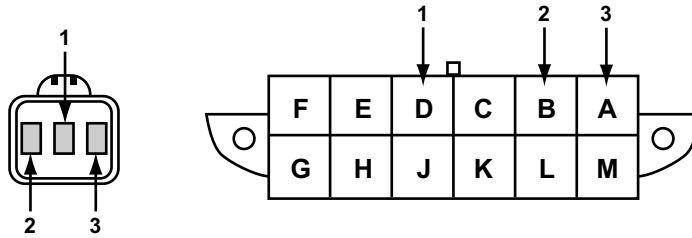

- 1— Check Engine lamp/data transmission
- 2— Test or diagnostic enable
- 3— Ground

Figure A-4 Isuzu and Isuzu-built Geo ALDL 3-pin and 12-pin connectors



To check ground continuity:

1. Connect the voltmeter positive (+) lead to ALDL pin A on the 12-pin connector, or to pin C on the 3-pin connector.
2. Connect the negative (-) lead to the negative battery terminal. Use jumper wires as needed.



NOTE:

Do not connect to a body or chassis ground; go directly to the negative battery terminal.

3. Measure voltage drop with the ignition switched on.
Voltage drop across the ground terminal should be 0.1 V or less. An open or high resistance ground prevents the ECM from entering the diagnostic mode.



To test for an open ground at ALDL pin A (or C):

1. Turn the ignition on and jumper pin B to pin A in the 12-pin ALDL connector, or pin A to pin C on the 3-pin connector.
2. Connect the voltmeter positive lead to the jumper and the negative lead to a known good ground; connect directly to the negative battery terminal if possible.
 - The meter should read 50 millivolts (0.050 V) or less for a good ground (Figure A-5 on page 527).
 - Higher readings indicate a high-resistance ALDL ground connection.
 - If the meter reads 5 V, the ALDL ground connection is open.

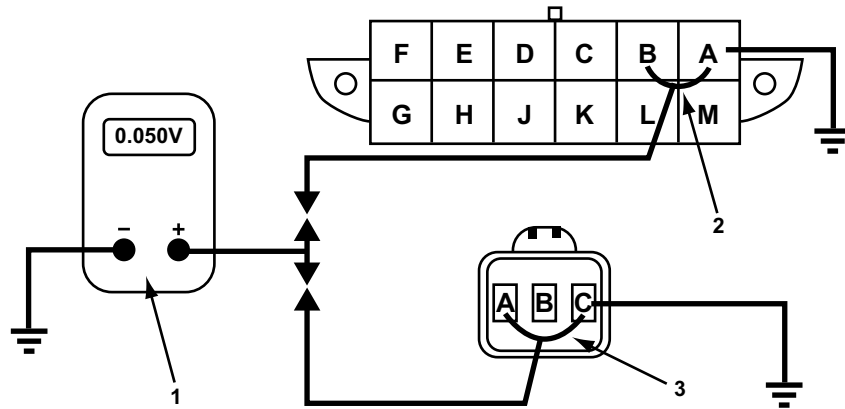

- 1— Voltmeter
- 2— Jump pin B to pin A
- 3— Jump pin A to pin C

Figure A-5 Ground continuity for the ALDL connector



To check voltage on the test terminal:

- Connect the voltmeter positive lead to pin B of the 12-pin ALDL connector, or to pin A of the 3-pin connector, and the negative lead to the ALDL ground pin or a good ground.
With the ignition on, voltage should be 5 V. If the test terminal (pin B or pin A) circuit is open, a 160-baud ECM cannot switch into diagnostic mode.



To check voltage on pin B of the 3-pin connector (Check Engine lamp):

- Connect the voltmeter positive lead to ALDL pin B and the negative lead to the ground pin or a known good ground.
 - With the ignition on and the engine off, voltage on pin B should be less than 1 V (0.7 to 0.8 V) when the lamp is on.
 - When the lamp is off with the engine running, the meter should read battery voltage.
 If the circuit to pin B is open, the ECM cannot transmit data to the scan tool.



To check voltage on pin E of the 12-pin connector:

- Connect the positive voltmeter lead to connector pin E and the negative lead to either pin A or a good ground.
With the ignition on, voltage should be 5 V or fluctuating between 3.5 and 5.0 V. If the circuit is open, the ECM cannot transmit data to the scan tool.

Glossary

Numerics

2WD

Two wheel drive

4EAT

4-speed Electronic Automatic Transmission

4WD

Four Wheel drive

A

A/C

Air Conditioner

A/F

Air/Fuel

AAT

Ambient Air Temperature. Air temperature surrounding the vehicle.

ABS

Antilock Brake System

ACCEL

accelerator

ACTV

Active

ADJ

adjust (or adjustment)

ADV

advance

ALDL

Assembly Line Diagnostic Link

ASYNCH

Asynchronous

ATC

Automatic Transfer case

B

BARO

Barometric pressure. Pertaining to atmospheric pressure or the results obtained by using a barometer.

Baud rate

The speed at which the scan tool communicates with a vehicle ECM and records data movies. The baud rate depends on the vehicle ECM—it is not controlled by the scan tool.

BCM

Body Control Module

BLM

Block Learn Multiplier

C

C/OFF

Cutoff

CAN

Controller Area Network

CCP

Charcoal Canister Purge

CHT

Cylinder Head Temperature

CKP

Crankshaft Position

CKT

Circuit

CLSD

Closed

CMP

Camshaft Position Sensor

codes

A numerical code, generated by the vehicle control system to indicate a fault has occurred in a particular subsystem, circuit, or part.

CTP

Closed Throttle Position

D

D/M

Dual Mode

DAB

Driver Airbag

DCCSV

Damper Clutch Control Solenoid Valve ,

D-Check

Dealer check

DECEL

Decelerate

DIS

Direct (distributorless) Ignition System. A system in which the ignition coil secondary circuit is dedicated to specific spark plugs without the use of a distributor. Also referred to as the Electronic Ignition (EI) system.

DRVR

Driver

DTC

Diagnostic Trouble Code. An alphanumeric identifier for a fault condition identified by the on-board diagnostic system.

E

ECC

Electronically-Controlled Carburetor

ECCS

Electronic Concentrated Control System

ECM

Electronic Control Module

ECON

Economy

ECS

Electronic Control System or Evaporative Control System

ECU

Electronic Control Unit

EFC

Electronic Feedback Control

EFE

Early Fuel Evaporation. Enhancing air/fuel vaporization during engine warmup.

EGI

Electronic Gasoline Injection

EI

Electronic Ignition system. A system in which the ignition coil secondary circuit is dedicated to specific spark plugs without the use of a distributor. Also referred to as the Direct or Distributorless Ignition System (DIS).

ELEC

Electric or Electronic

EMB

Electromagnetic Brake

ENG

Engine

EOT

Engine Oil Temperature

F

FC

Fuel Cut or Fan Control

FT

Fuel Trim

G

GEN

Generator

H

Hz

Hertz (cycles per second)

I

IAC

Idle Air Control. Electrical or mechanical control of throttle bypass air.

IAT

Intake Air Temperature. Also referred to as Manifold Air Temperature (MAT).

IGN

Ignition

inHg

Inches of mercury

INJ

Injector

ISC

Idle Speed Control. Electronic control of minimum throttle position.

K

K/D
Kickdown

kPa
Kilopascals

L

LCKD
Locked

LED
Light-Emitting Diode

M

MAT
Manifold Air Temperature. Also referred to as Intake Air Temperature (IAT).

MES
Memory Erase Signal

MFI
A fuel-delivery system in which each cylinder is individually fueled. Also referred to as Multi-Point Injection (MPI).

movie
A vehicle data record whose length depends on the number of selected data parameters.

MPFI
Multiport Fuel Injection

MPI
Multi-Point Injection. A fuel-delivery system in which each cylinder is individually fueled. Also referred to as Multiport Fuel Injection (MFI).

mS
Milliseconds

mV
Millivolts

O

O₂
Oxygen

O₂S
Oxygen Sensor. A sensor which detects oxygen (O₂) content in the exhaust gases.

OD
Overdrive

P

P/S

Power Steering

PAB

Passenger Airbag

PASS

Passenger

PCM

Powertrain Control Module

Personality Key™

A device that identifies a manufacturer's configuration for the vehicle diagnostic connector to the scan tool.

PIP

Position Indicator Pulse

POS

Position

psi

Pounds per square inch

PSP

Power Steering Pressure

PW

Pulse Width

PWM

Pulse-Width Modulation

PWR

Power ,

R

REF

Reference

RF

Right Front or Radio Frequency

RPM

Revolutions Per Minute (engine speed)

S

SCS

Service Check Signal

SOL

Solenoid

SPI

Single Point Injection. An electronically controlled fuel injection system in which one or more fuel injectors are located in a throttle body. Also referred to as Throttle Body Fuel Injection (TBI).

SRS

Supplemental Restraint System (airbags)

SW

Switch

T

TAC

Throttle Actuator Control

TCM

Transmission Control Module

TCS

Traction Control System

TEMP

Temperature

TFP

Transmission Fluid Pressure. Positive pressure in a transmission hydraulic system.

THROT

Throttle

TP

Throttle Position

V

V

Voltage or Volts

VAC

Vacuum

VEH

Vehicle ,

VIN

Vehicle Identification Number

VPWR

Vehicle Power

VSS

Vehicle Speed Sensor

VSV
Vacuum Switching Valve

VTD
Vehicle Theft Deterrent

VVT
Variable Valve Timing

W

WOT
Wide Open Throttle

X

XFER
Transfer

Index

Numerics

- 2.2 CL
 - 1997 engine connector locations 13
 - 1997 transmission connector locations 20
- 2.3 CL
 - 1998–1999 engine connector locations 13
 - 1998–1999 transmission connector locations 20
- 2.5 TL
 - 1995 connector locations 14
 - 1995–1996 SRS code reading 30
 - 1995–1998 engine connector locations 13
 - 1995–1998 transmission connector locations 20
- 2004 RL
 - 2004 ABS code reading 26
- 3.0 CL
 - 1997–1999 engine connector locations 13
 - 1997–1999 transmission connector locations 20
- 3.2 CL
 - 2001–2003 engine connector locations 13
 - 2001–2003 transmission connector locations 20
- 3.2 TL
 - 1995 connector locations 14
 - 1996–2003 engine connector locations 13
 - 1996–2003 transmission connector locations 20
 - 2004 engine connector locations 13
 - 2004 transmission connector locations 20
- 3.5 RL
 - 1996–2003 engine connector locations 13
 - 1996–2003 transmission connector locations 20
 - 2000–2002 ABS code reading 26
 - 2004 engine connector locations 13
 - 2004 transmission connector locations 20
 - SRS code reading 30
- 3000 GT
 - 1991–1999 connector locations 118
- 300ZX
 - 1985–1989 code reading 127
- 626
 - 1988–1992 ABS code reading 112

A

- ABS 184
- Accent
 - 1995–2004 connector locations 78

- Accord
 - 1986–1989 LXI ECM and LED locations 57
 - 1990 and later connector locations 58
 - 1994–2004 4-cylinder connector locations 55
 - 1995–1997 SRS code clearing 73
 - 1995–2004 V6 connector locations 55
 - 1998–2003 SRS code clearing 74
 - 2004 SRS code clearing 74
- Acura 12–32
 - 2-pin service check signal (SCS) connector 13
 - 3-pin DLC 13
 - Code Reading Connectors and Locations 12
 - Common connector locations 12
 - DLC locations 14
 - Engine Code Type 03 18
 - Engine System Testing
 - Multiple Codes 18
 - Testing Antilock Brake Systems (ABS) 22
 - ABS Codes and Data Testing 23
 - ABS MAIN MENU 23
 - CLEAR CODE 25, 29, 67
 - CODE ONLY 24, 29, 66
 - CODES & DATA MENU 24, 28, 66
 - DATA (NO CODES) 24, 29, 66
 - Manual Code Reading and Clearing 25
 - Code Reading connectors and locations 22
 - Testing Engine Systems 12
 - Testing Supplemental Restraint Systems (SRS) 28
 - Code Clearing 31
 - Manual Code Reading 29
 - SRS Codes and Data Testing
 - SRS MAIN MENU 28
 - Testing Transmission Systems 19
 - Code Reading connector locations 19
 - Transmission service check connector locations 19
 - Amigo
 - 1988–1995 connector locations 84
 - 1990–1994 ABS connector locations 89
 - 1990–1994 engine connector locations 81
 - 1990–1994 transmission connector locations 82
 - Ascender
 - 2003–2004 engine connector locations 81
 - Avenger
 - 1995–2000 connector locations 34
 - Axiom
 - 2002–2004 engine connector locations 81

B

- B-Series
 - 1990–1993 ABS code reading 113

C

- Celica
 - 2000 and later SRS code reading 203
- Chrysler Imports 33–??
 - Testing Engine, Transmission, ABS, and SRS Systems 33
 - ABS Manual Code Reading 36
 - Actuator Tests 37
 - Clearing Codes 36
 - Code Reading Connectors and Locations 33
 - Codes & Data (Slow) 37
 - Common connector locations 33
 - Injector Tests (Engine Running Only) 37
 - troubleshooting 523
- Civic
 - 1985–1991 ECM and LED locations 57
 - 1992–2004 connector locations 55
 - 1994–2000 SRS code clearing 72
 - 2001–2004 SRS code clearing 75
- Code 129
- Colt
 - 1987–1996 turbo connector locations 34
 - 1988–1990 wagon connector locations 34
 - 1989–1996 connector locations 34
- Conquest
 - 1984–1989 connector locations 34
- Cordia
 - 1984–1988 connector locations 118
- Cressida
 - 1983–1984 connectors 199
 - troubleshooting 523
- CR-V
 - 1997–2001 SRS code clearing 75
 - 1997–2004 connector locations 55
 - 2002–2004 SRS code clearing 75
- CRX
 - 1985–1987 ECM and LED locations 57

D

- Daihatsu 40–43
 - Testing Engine and Transmission Systems and ABS 40
 - Code Reading Connectors and Locations 40
 - Manual Code Reading 41
 - Testing Transmission Systems 42
 - Code Reading Connector Locations 42
 - transmission system testing 42
- D-Check connectors. See diagnostic connectors

- del Sol
 - 1992–1997 SRS code clearing 72
 - 1993–1997 connections locations 55
 - 1993–1997 connector locations 55
- diagnostic connectors
 - D-Check 166
 - Read Memory 166
- Diamante
 - 1992–2004 connector locations 118

E

- Echo
 - 2000 and later SRS code reading 203
- Eclipse
 - 1990–2005 connector locations 118
- EEC-IV functional tests 106, 109
 - Computed Timing test 106
 - Idle Speed Adjustment test 108
 - Output State Check 107
 - Wiggle (Engine Off) test 106
 - Wiggle (Engine Running) test 107
- EEC-V Functional Tests 106
- EEC-V functional tests
 - Output State test 109
- EGI-MGI
 - 1983–1984 Read Memory and D-Check connectors 168
- Elantra
 - 1992–2004 connector locations 78
- Element
 - 2003–2004 connector locations 55
 - 2003–2004 SRS code clearing 75
- Endeavor
 - 2004 connector locations 118
- Excel
 - 1990–1994 connector locations 78
- Expo/LRV
 - 1992–1996 connector locations 118

F

- For 88

G

- Galant
 - 1985–2005 connector locations 118
- Generic OBD-II Operations 207–213
 - 6-pin OBD-II connector pinout 208
 - Connecting To The Vehicle 208
 - OBD-II and What it Means 207
 - Selecting The Generic Test Mode 208
- Geo 44–??
 - Testing Engine, Transmission, and Antilock Brake Systems 44
 - Clearing Codes 51
 - Code Reading Connectors and Locations 44

- Field Service Functional Tests 52
- Hard Codes and Soft Codes 51
- Manual Code Reading 49
- Prizm Actuator Tests 52
- troubleshooting 525

H

- Honda 54–76
 - Testing Engine and Transmission Systems 54
 - Code Reading Connectors and Locations 54
 - Code Type 57
 - ECM Locations 57
 - Manual Code Reading 62
 - SCS mode 56
 - 16 pin DLC 56
 - 2 pin SCS connector 56
 - Two-trip detection bypass 56
 - Testing Supplemental Restraint Systems (SRS) 66
 - Manual Code Reading 67
 - SRS Codes and Data Testing
 - SRS MAIN MENU 66
- Hyundai 77–??
 - Testing Engine, Transmission, ABS, and SRS Systems 77
 - Actuator Tests 79
 - Clearing Codes 79
 - Code Reading Connectors and Locations 77
 - Injector Tests (Engine Running Only) 79

I

- I-Mark
 - 1984–1989 engine connector locations 81
 - 1985½–1989 code reading 85
- Impreza
 - 1993–1994 transmission code reading 181, 182
 - 1993–1995 connector locations 146
 - 1995 connector locations 148
- Impulse
 - 1984–1992 engine connector locations 81
 - 1988–1989 code reading 85
 - 1990 and later code reading 85
 - 1990–1992 ABS connector locations 89
 - 1990–1992 transmission connector locations 82
- Infiniti. See Nissan/Infiniti
- Insight
 - 2000 connector locations 55
 - 2000–2004 SRS code clearing 76
 - 2001–2004 connections locations 55
- Instrument Panel Cluster (IPC) Parameters 476

- Integra
 - 1986–1989 LED locations 14
 - 1990 and later code reading 18
 - 1990–1993 ABS connector locations 23
 - 1990–1995 transmission connector locations 19
 - 1992–2001 engine connector locations 13
 - 1996–2001 transmission connector locations 20
- Isuzu 80–??
 - Testing Antilock Brake System (ABS) 88
 - Code Reading Connectors and Locations 88
 - Manual Code Reading 90
 - Clearing Codes 93
 - Code Type 02 91
 - Code Type 05a 92
 - RWAL ABS Code Type 90
 - Testing Engine and Transmission Systems 80
 - Clearing Codes 87
 - Code Reading Connectors and Locations 80
 - Field Service Functional Tests 88
 - Manual Code Reading (Engine) 86
 - Road Test (No C&D) 87
 - Testing Supplemental Restraint Systems (SRS) 93
 - Manual Code Reading 94
 - Clearing Codes 97
 - Code Type 02a 94
 - Code Type 03 96
 - Testing Transfer Case and Body Control Module (BCM) 97
 - troubleshooting 525

J

- Justy
 - 1987 D-check procedure 174
 - 1987 Read Memory and D-Check connectors 170
 - 1988–1990 Read Memory and D-Check connectors 171
 - 1988–1991 D-check procedure 175
 - 1989–1994 ECVT transmission code reading 183
 - connector locations 145

K

- Kia 98–101
 - Testing Engine, Transmission, and Antilock Brake Systems 98
 - Code Reading 98
 - Manual ABS Code Reading 101

L

- Lancer
 - 2002–2005 connector locations 118
- Lancer Sport Back
 - 2004 connector locations 118
- Laser
 - 1990–1994 connector locations 34

Legacy
1990 Read Memory and D-Check connectors 171
1990–1994 connector locations 146
1990–1994 transmission code reading 181, 182

Legend
1986–1990 ABS connector locations 22
1986–1990 sedan LED locations 14
1987–1990 coupe transmission connector locations 19
1988–1990 sedan transmission connector locations 19
1991 code reading 18
1991–1994 ABS connector locations 22

Lexus. See Toyota

Loyale
1987–1992 transmission code reading 181
connector locations 145

LS400
troubleshooting 523

L-Series
1987–1990 Read Memory and D-Check connectors 171

M

Mazda 102–116
engine system testing 102
Functional Test
 Computed Timing Test 106
 Wiggle (Engine OFF) test 106
Functional Tests 106, 109
 Idle Speed Adjustment Test 108
 Output State Check 107
 Output State Test 109
 Wiggle (Engine Running) Test 107
Testing Airbag, GEM, ICM & Transfer Case Systems through the 16 Pin Connector 116
Testing Antilock Brake Systems 111
 ABS Main Menu 113
Testing Engine and Transmission Systems 102
 Code Reading 102
 EEC-IV Functional Tests 106
 EEC-V Functional Tests 109
 Functional Tests 104, 105
 Manual Code Reading 103
 Transmission Code Retrieval 110
transmission system testing 102

MDX
2001–2004 engine connector locations 13
2001–2004 transmission connector locations 20

Metro
1989–1992 engine code reading 45
1992–1994 1.0L transmission code reading 48
1992–1995 1.3L transmission code reading 48
1992–1995 engine code reading 47
1995 1.0L transmission code reading 48

Mirage
1989–2002 connector locations 118

Mirage Turbo
1985–1988 connector locations 118

Mitsubishi 117–??
Testing Engine, Transmission, ABS, and SRS Systems 117
 ABS Manual Code Reading 121
 Actuator Tests 122
 Clearing Codes 122
 Code Reading Connectors and Locations 117
 Codes & Data (Slow) 122
 Injector Tests (Engine Running Only) 123
 Transmission Manual Code Reading 121
troubleshooting 523

Montero
1989–2005 connector locations 118

Montero Sport
1997–2004 connector locations 118

MPV
1990–1993 ABS code reading 113

MR2
2000 and later SRS code reading 203

MX6
1988–1992 ABS code reading 112

N

Navajo
1993–1994 4WAL code reading 112

Nissan
troubleshooting 524

Nissan/Infiniti 124–137
Testing Controller Area Network (CAN) Systems 137
Testing Engine Systems 124
 Air/Fuel Check (Mode 2) 130
 Base Idle Test 132
 Code Reading Connectors and Locations 124
 Code Type 07 125
 Code Type 07a 126
 Code Type 07a-Five Mode System 127
 Code Type 07b-Two Mode System 129
 Exhaust Monitor Test (Mode 1) 130
 Functional Tests 129
 Real-Time Monitor (Mode 5) 131
 Self-Diagnostic (Mode 3) 131
 Switch Test (Mode 4) 131
Testing Supplemental Restraint Systems (SRS) 135
 Manual Code Reading 135
Testing Transmission Systems 132
 Nissan 4EAT Transmission Testing 133
transmission system testing 132

NSX

- 1991 code reading 18
- 1991–1995 ABS connector locations 22
- 1991–1995 transmission connector locations 19
- 1995 connector locations 14
- 1995–2003 engine connector locations 13
- 1995–2003 transmission connector locations 20
- 2003–2004 ABS code reading 26
- 2004 engine connector locations 13

NSX-T

- 2004 transmission connector locations 20

O

Occupant Classification (OCC) Parameters 475

Odyssey

- 1995–2004 connector locations 55
- 1996–1998 SRS code clearing 73
- 1999–2002 SRS code clearing 73

Outlander

- 2003–2005 connector locations 118

P

Passport

- 1994–1995 connector locations 58
- 1994–2002 connector locations 55
- 1996–2002 with 4WAL code clearing 65
- 1996–2002 with RWAL code reading 65

Pickup, Isuzu

- 1984–1985 connector location 84
- 1990–1995 ABS connector locations 89
- 1990–1995 engine connector locations 81
- 1990–1995 transmission connector locations 82

Pilot

- 2003–2004 connector locations 55
- 2003–2004 SRS code clearing 76

Precis

- 1990–1994 connector locations 118

Prelude

- 1985–1991 ECM and LED locations 57
- 1990 and later connector locations 58
- 1992–2001 connector locations 55
- 1994–1996 SRS code clearing 73
- 1997–2001 SRS code clearing 72

Prizm

- 1989–1995 connector locations 45
- 1992 with 4AGE transmission code reading 49
- 1993–1995 with 7AFE transmission code reading 49
- actuator tests 52

R

Raider

- 1989 connector locations 34

RAM 50

- 1994 connector locations 34

Read Memory connector. See diagnostic connectors

Rio

- 2001–2002 ABS code reading 100

Rodeo

- 1990–1995 ABS connector locations 89
- 1990–1995 transmission connector locations 82
- 1990–2004 engine connector locations 81
- 1991–1995 connector locations 84

RSX

- 2002–2004 engine connector locations 13
- 2002–2004 transmission connector locations 20

S

S2000

- 2000–2003 SRS code clearing 74
- 2000–2004 connector locations 55
- 2004 SRS code clearing 74

Safety iii–iv

safety

- information iii

Santa Fe

- 2001–2004 connector locations 78

Scion. See Toyota

Scoupe

- 1991–1995 connector locations 78

SCS 56

Sebring

- 1995–2000 connector locations 34

Sebring Coupe

- 2004 connector locations 34

Sephia

- 1995–1997 ABS code reading 100
- 2000–2001 ABS code reading 100

Sigma

- 1988–1990 connector locations 118

SLX

- 1996–1997 ABS connector locations 23
- 1996–1999 engine connector locations 13
- 1996–1999 transmission connector locations 20

Sonata

- 1989–2004 connector locations 78
- troubleshooting 523

Spectra

- 2000–2001 ABS code reading 100

Spectrum

- 1989 46
- 1989 engine code reading 46

SPI

- 1986 Read Memory and D-Check connectors 169
- 1987–1990 Read Memory and D-Check connectors 170

Sportage

- 1994–2001 ABS code reading 99

Starion

- 1984–1989 connector locations 118

Stealth
 1991–1996 connector locations 34

Storm
 1990–1994 46
 1990–1994 engine code reading 46
 1992–1994 1.8L transmission code reading 47

Stratus Coupe
 2004 connector locations 34

Stylus
 1990–1993 ABS connector locations 89
 1990–1993 engine connector locations 81
 1990–1993 transmission connector locations 82

Subaru 143–196
 1983–1984 turbo connector locations 144
 Code Reading Connector Locations 143
 Testing ABS Systems 184
 Code Information 184
 Code Reading and Connector Locations 185
 Code Types 184
 Testing Airbag (SRS - Supplemental Restraint Systems) 191
 Code Information 192
 Code Reading and Connector Locations 192
 Code Types 192
 Testing Engine Systems 143
 Code Reading Connectors Locations 143
 Connecting the scan tool to the vehicle 148
 Reading Engine Codes 150
 Code Type 08 176
 Subaru Vehicle Connection Table 151
 Vehicle Connection Diagrams 159
 Testing Transmission Systems 180
 1987 to 1992 4EAT Transmission (Version 1) 181
 1989 to 1994 Just ECVT Transmission 183
 1990 to 1996 4EAT Transmission (Version 2) 181
 1990 to 1996 4EAT Transmission (Version 2) History Codes 182
 1996 to 2005 Subaru Models with an OBD-II connector 184
 Code Reading 180

Summit
 1989–96 connector locations 34

Summit Wagon
 1992–1996 connector locations 34

Supra
 1983–1984 connectors 199

SVX
 1992–1996 transmission code reading 181, 182
 connector locations 147

T

Talon
 1990–1994 connector locations 34
 1995–1998 connector locations 34

Testing 19

Tiburon
 1997–2004 connector locations 78

Toyota/Lexus/Scion 197–206
 1995 and earlier vehicle ID 197
 actuator tests 200
 airbag (SRS) system testing 203
 antilock brake system (ABS) testing 202
 engine system testing 197
 Testing ABS Systems
 Code Reading Connectors 202
 Testing Engine Systems 197
 Actuator Tests 200
 Code Reading Connectors and Locations 198
 Code Sensitivity 199
 Data (No Codes) 199
 Manual Code Reading 200
 Testing Supplemental Restraint Systems (SRS) 203
 Reading SRS Codes 203
 Testing Transmission Systems 201
 Code Reading Connectors 201
 Testing ABS Systems 202
 transmission system testing 201
 vehicle ID 197

Tracker
 1989–1995 engine code reading 46
 1990–1995 with Kelsey-Hayes RWAL code reading 49

Tredia
 1984–1988 connector locations 118

Trooper
 1984–1985 connector location 82
 1986–1987 2.3L engine connector locations 81
 1986–1987 code reading 82
 1988–1991 2.6L engine connector locations 81
 1988–1991 A/T connector and adapter 84
 1988–1991 connectors 83
 1989–1991 2.8L engine connector locations 81
 1990–1994 transmission connector locations 82
 1990–2002 engine connector locations 81

Truck, Chrysler Imports
 1990–1994 connector locations 34

Truck, Mitsubishi
 1990–1996 connector locations 118

TSX
 2004 engine connector locations 13
 2004 transmission connector locations 20

TSX/TL
 2004 SRS code clearing 32

V

- Van, Mitsubishi
 - 1987–1990 connector locations 118
- Vehicross
 - 1999–2001 engine connector locations 81
- Vigor
 - 1992–1994 ABS connector locations 22
 - 1992–1995 transmission connector locations 19
- Vista
 - 1987–1991 connector locations 34
 - 1992–1996 connector locations 34

W

- Wagon, Mitsubishi
 - 1987–1990 connector locations 118

X

- XG300/XG350
 - 2001–2004 78
- XT
 - 1986–1987 Read Memory and D-Check connectors 169
- XT/XT6
 - 1987–1991 transmission code reading 181
 - connector locations 147